



HEADER INSTALLATION INSTRUCTIONS

Corporate Office: PerTronix Inc. 440 E. Arrow Highway, San Dimas, California 91773 * Phone 909.599.5955 * FAX 909.599.6424 * www.patriotexhaust.com

Part #H8024/H8026 & H8024-1/H8026-1

70-74 Monte Carlo

70-72 Camaro, Floor Shift Only

68-74 Chevelle, Malibu, El Camino

71-74 Passenger Car & Wagons, Auto Column Shift Only

396-502 – Vehicles MUST have Original Style Big Block motor stands and motor mounts for Headers to fit properly. Small block stands will NOT work.



This product is Legal for use on 1974 Non-Catalyst equipped vehicles and is considered a "Replacement Part" per California Air Resources Board regulations, as long as ALL emissions sensitive components are retained, Including EGR, A.I.R., Heat Risers etc. Failure to retain any of these components , or use on 1975 or newer Catalyst equipped vehicles, would render this product Illegal for Street or Off Highway use and may only be used for Closed Course Competition.

PerTronix® thanks you for choosing **Patriot Headers**, the best value for the dollar of any brand in the industry. **Please read and understand these instructions completely prior to starting work.**

Check to make sure you received the proper parts for your application. The header number will be stamped on the engine flange. If you are unsure you have received the proper parts call before you start work.

Be sure to work safe! Whenever you work under the vehicle be sure that it is located on level, solid ground and is supported by adequate safety stands! **Remember: Hot asphalt will not support most jack stands!**

Many factors affect the installation of headers, some of which are broken or aftermarket motor mounts, accidents that impact the configuration of the frame, and/or the installation of different engines or aftermarket cylinder heads.

Attention Customers breaking in new engines: Due to the extreme heat generated during the break-in process, the appearance of the ceramic coating may be altered in certain areas. The protection characteristics and thermal barrier properties of the coating is never compromised. It is recommended that a cast iron manifold or old set of headers be used for this process.

Notice: The coating of these headers can be marred or scratched during installation. If the header needs to be returned and is damaged, you will be charged for recoat.

DISASSEMBLY

1. Disconnect the negative battery cable from the battery.
2. If a car lift is not available, raise the vehicle 2 feet or higher and support with adequate safety stands. Make sure the vehicle is on a flat solid surface and is stable.
3. Remove bolts attaching head pipes stock manifolds and move head pipes out of the way.
4. Remove the Spark Plugs, Clutch linkage (on std trans cars), Oil Filter, and Oil Dipstick & Tube. Remove Power Steering pump if it is mounted to the head. Remove Air Conditioning Compressor from head – do not disconnect lines as Freon will escape.
5. Remove stock exhaust manifolds and gaskets

6. Remove any remaining gasket or carbon deposits from the head surface. The use of a gasket scraper and or a gasket removal product may help. Be careful not to get any gasket pieces in ports or spark plug holes.

INSTALLATION

1. Starting on the Driver's side, Place a block of wood under the oil pan and remove the long center bolt from the motor mount. Lift the motor approx. 2"
2. Slip the header roughly into position from the bottom.
3. Some applications, mainly 72-74 models, may require modifying the motor mount as shown in Illustration A.
4. Slowly lower the motor back into position while checking for header clearance. Re-install the motor mount bolt and tighten.
5. Using the supplied 3/8-16X1" Header bolts and lock washers, slip the gasket in place and start center two header bolts. Do NOT tighten at this time.
6. Re-install the clutch linkage, spark plugs and oil filter.
7. Check the brake line for clearance and reroute as necessary as shown in Illustration J.
8. If Air Conditioning is mounted to driver's side the bracket will need to be modified. See Illustration B for 68-72 models. See Illustration C for 73-74 models.
9. If power steering pump is mounted to drivers side re-install, some 1968 models will require fabrication of a spacer as shown in Illustration D.
10. After installing A/C and/or Power Steering, install the remainder of the header bolts and tighten evenly to 35 ft. lbs.

Passenger side; Headers clearances on this side are extremely tight. To increase Clearances these modifications may or may not be necessary, but should improve clearances if warranted

- a. Bend or Remove frame support brace if equipped. See Illustration E
 - b. Trim A Arm Bolts flush with nuts. See Illustration F
 - c. Slightly flatten header pipe. See Illustration G
11. Slip the right side header roughly into position from the bottom.
 12. Using the supplied 3/8-16X1" Header bolts and lock washers, slip the gasket in place and start the center two header bolts. Do NOT tighten at this time.
 13. If air conditioning is mounted to the passenger's side, modify the bracket as shown in Illustration H or I and fabricate spacers as needed. Use stock manifold bolts to re-install the bracket.
 14. Install the remainder of the header bolts and tighten evenly to 35 ft lbs for stock heads.
 15. If automatic transmission car, check for clearance between headers and transmission cooler lines and reroute as necessary.
 16. Re-install spark plugs and dip stick tube.
 17. If reusing the existing exhaust system cut and modify as necessary to connect to the headers using Patriot Reducers.
 18. Connect the negative battery cable.

IMPORTANT CHECK LIST

- Be sure that all brake lines and fuel lines are clear of headers and/or connector pipes.
- All spark plug wires, battery cables, or other electrical components should be clear of headers and/or connector pipes.

- If dipstick tube was removed, make sure it is installed properly and that the dipstick has been replaced.
- Double-check the tightness of all bolts including brackets and accessories.

STARTING THE ENGINE

Start the engine and allow it to warm up to operating temperature. Check for any unusual noises or exhaust leaks. If everything is OK, stop the engine and tighten all bolts while the engine is still warm.

NOTE: Check the bolts periodically to make sure they have not loosened. Re-tighten after the first 500 miles and then again at 1000 miles.

PARTS LIST

| Qty | Description |
|-----|------------------------------------|
| 1 | Left Side Header |
| 1 | Right Side Header |
| 2 | Header Gaskets |
| 16 | 3/8-16x1" Header Bolts |
| 6 | 3/8-16x1" Collector Hex Head Bolts |
| 6 | 3/8-16 Hex Nuts |
| 6 | 3/8" Lock Washers |
| 2 | Reducers |
| 2 | Reducers Gaskets |

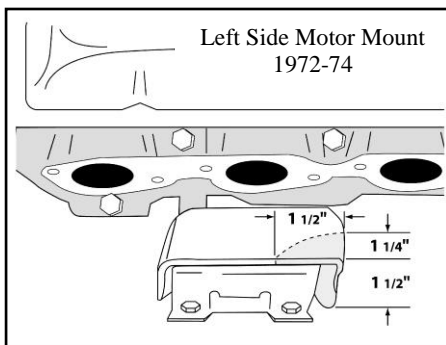

Illustration A

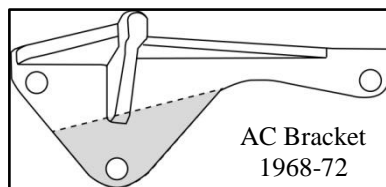

Illustration B

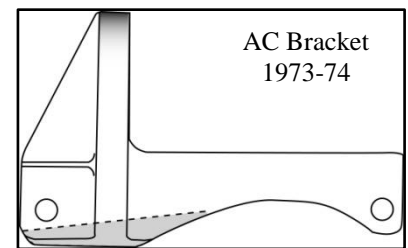

Illustration C

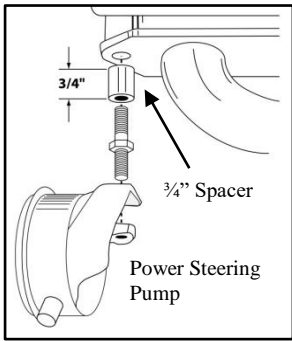

Illustration D

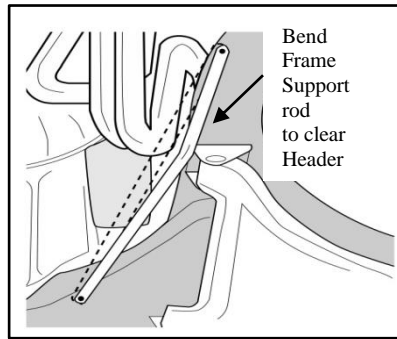

Illustration E

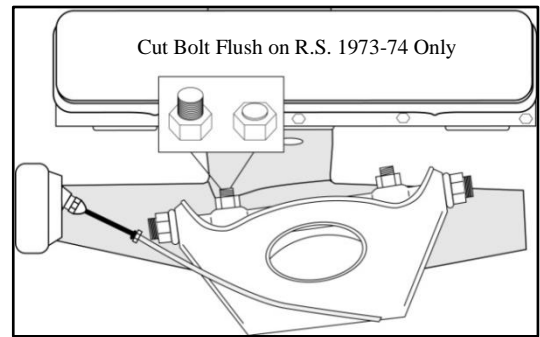

Illustration F

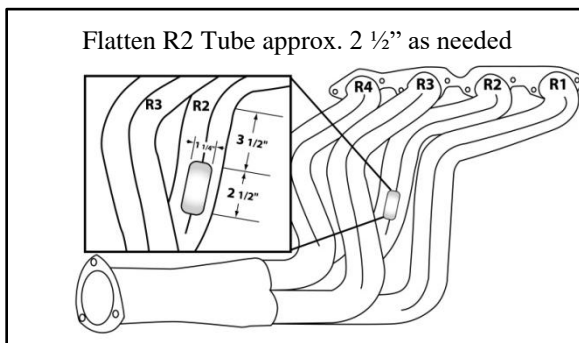

Illustration G

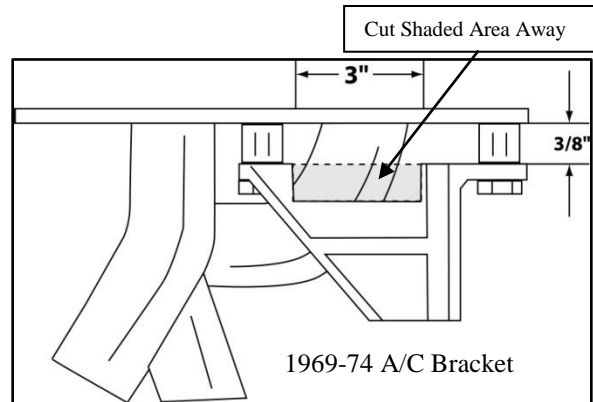

Illustration H

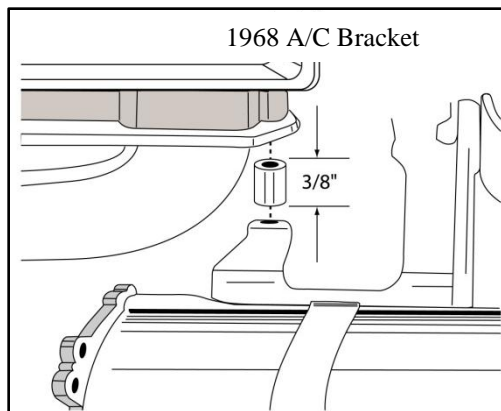

Illustration I

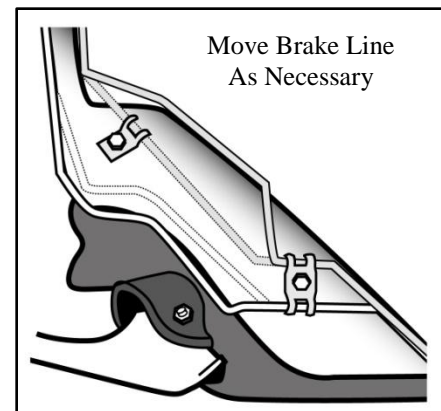

Illustration J

⚠ WARNING:
 This product can expose you to chemicals including Lead, Nickel, Cadmium and Chromium which are known to the State of California to cause cancer and birth defects or other reproductive harm. For more information go to www.P65Warnings.ca.gov