

PATRIOT™

Exhaust Products

Corporate Office: PerTronix Inc. 440 E. Arrow Highway, San Dimas, California 91773 * Phone 909.599.5955 * FAX 909.599.6424 * www.patriotexhaust.com

HEADER INSTALLATION INSTRUCTIONS

H8426

65-70 Mustang, 67-70 Cougar ~ 260-302

NOTE: Power Steering requires bracket part #H7609



This product is Legal for use on 1974 Non-Catalyst equipped vehicles and is considered a "Replacement Part" per California Air Resources Board regulations, as long as ALL emissions sensitive components are retained, Including EGR, A.I.R., Heat Risers etc. Failure to retain any of these components , or use on 1975 or newer Catalyst equipped vehicles, would render this product Illegal for Street or Off Highway use and may only be used for Closed Course Competition.

PerTronix® thanks you for choosing **PATRIOT Exhaust Products**, the best value for the dollar of any brand in the industry. Please read and understand these instructions completely prior to starting work.

CHECK TO MAKE SURE YOU RECEIVED THE PROPER PARTS FOR YOUR APPLICATION. IF YOU ARE UNSURE YOU HAVE RECEIVED THE PROPER PARTS, CALL BEFORE YOU START WORK.

BE SURE TO WORK SAFE! WHENEVER YOU WORK UNDER THE VEHICLE BE SURE THAT IT IS LOCATED ON LEVEL, SOLID GROUND AND IS SUPPORTED BY ADEQUATE SAFETY STANDS!

REMEMBER: HOT ASPHALT WILL NOT SUPPORT MOST JACK STANDS!

Many factors affect the installation of headers, some of which are broken or aftermarket motor mounts, accidents that impact the configuration of the frame, and/or the installation of different engines or aftermarket cylinder heads. Most installations require some welding. If you are uncomfortable with welding operations, we recommend that you contact a professional exhaust system specialist to install your new headers.

Attention Customers breaking in new engines: Due to the extreme heat generated during the break-in process, the appearance of the ceramic coating may be altered in certain areas. The protection characteristics and thermal barrier properties of the coating is never compromised. It is recommended that a cast iron manifold or old set of headers be used for this process.

Notice: The coating of these headers can be marred or scratched during installation. If the header needs to be returned and is damaged, you will be charged for recoat.

DISASSEMBLY

1. Disconnect the negative battery cable from the battery.
2. If a car lift is not available, raise the vehicle 2 feet or higher and support it with adequate safety stands. Make sure the vehicle is on a flat solid surface and is stable.
3. Apply penetrating oil to all nuts and bolts to be removed.
4. Remove and mark all spark plug wires and then remove all spark plugs..
5. Disconnect the head pipes from the exhaust manifolds and remove the manifolds.
6. Replace the spark plugs finger tight so debris will not get into the cylinders during the cleaning operation.

7. Remove the clutch linkage (if manual transmission)
8. Remove the power steering ram from the frame.
9. Remove any gasket material or any carbon deposits that remain on the head surface. The use of a gasket removal agent will ease the removal of any gasket material. We recommend the use of a sharp gasket scraper to remove the bulk of material and to finish the operation with a sanding block to provide a clean flat sealing surface.
10. After cleaning is complete remove the spark plugs again.

ASSEMBLY

1. Start the left header from below and work it up through the chassis into position over the exhaust ports.
2. With the header loose, replace the clutch linkage (if removed).
3. Start all the header bolts and tighten evenly.
4. Tighten all the header bolts evenly to a final torque of approximately 35 ft. lbs.
5. Reinstall the power steering ram with a purchased bracket P/N H7609. It may be necessary to reroute the power steering lines for header clearance.
6. Automatic Transmission: Check the kickdown linkage. It may be necessary to bend the linkage towards the engine until it will work properly. Check the steering lockout rod, which may also require bending (to fit) or removal. If removed, the linkage to which it was attached must be wired in place to prevent steering from locking while the vehicle is moving.
7. Replace the spark plugs. When you install the spark plugs, apply a **small** amount of anti-seize to the threads.
8. Start the right header from below and work it up through the chassis into position over the exhaust ports.
9. Start all the header bolts and tighten evenly
 - a. Note: It may be necessary to reroute the automatic transmission cooling lines and/or starter cables for adequate header clearance.
10. Tighten all the header bolts evenly to a final torque of approximately 35 ft. lbs.
11. Replace the spark plugs. When you install the spark plugs, apply a **small** amount of anti-seize to the threads.
12. If the collector contacts the emergency brake cable, the bracket must be relocated so the cable will clear. See Figures A & B on Page 4.
13. Use the supplied reducers to connect the collectors to your stock exhaust system.
14. Connect the negative battery cable.

START THE ENGINE

Start the engine and allow it to warm up to operating temperature. Check for any unusual noises or exhaust leaks. If every thing is OK, stop the engine and tighten all bolts while the engine is still warm.

NOTE: Check the bolts periodically to make sure they have not loosened. Re-tighten after the first 500 miles and then again at 1000 miles.

IMPORTANT CHECK LIST

- Be sure that all brake lines and fuel lines are clear of headers and/or connector pipes.
- All spark plug wires, battery cables, or other electrical components should be clear of headers and/or connector pipes.
- If dipstick tube was removed, make sure it is installed properly and that the dipstick has been replaced.
- Double-check the tightness of all bolts including brackets and accessories.

PARTS LIST

<u>Qty</u>	<u>Description</u>		
1	Left side header	1	Right side header
2	Reducers	2	Header gaskets
2	3" reducer gaskets	16	3/8"-16 x 3/4" header bolts
6	3/8"-16 x 1" hex head cap screws	6	3/8"-16 hex nuts

 **WARNING:**

This product can expose you to chemicals including Lead, Nickel, Cadmium and Chromium which are known to the State of California to cause cancer and birth defects or other reproductive harm. For more information go to www.P65Warnings.ca.gov

FIGURE A

(VIEW FROM UNDER THE VEHICLE)

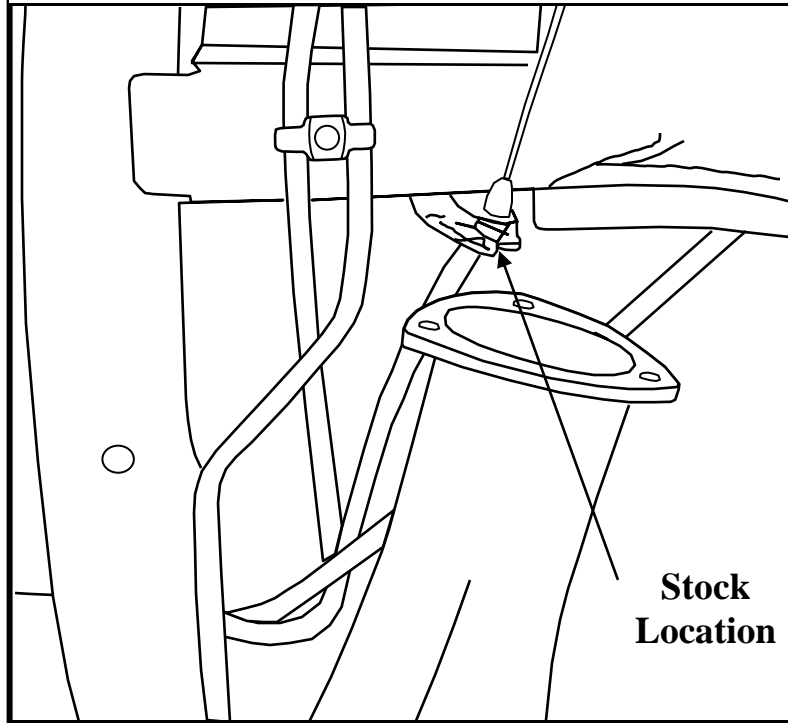

FIGURE B

(VIEW FROM UNDER THE VEHICLE)

