



**AEROMOTIVE**  
**Part # 19105,19106,19107, and 19108**  
**Brushless In-Tank Pump Module**  
**2011-2017 Mustang (S197/S550)**  
**2018-2020 Mustang GT/EcoBoost**  
**INSTALLATION INSTRUCTIONS**

This product is not legal for sale or use on emission-controlled vehicles except when used as a direct replacement part matching OEM specification.

**WARNING!**



Always be aware of flammable situations. Drilling and grinding can be potential ignition sources. Extinguish all open flames, prohibit smoking and eliminate all sources of ignition in the area of the vehicle and workspace before proceeding with the installation. Ensure you are working in a well ventilated area with an approved fire extinguisher nearby.

**WARNING!**



etc.

Installation of this product requires modification to a fuel tank/ the fuel system, failure to satisfy all safety considerations will result in fire, explosion, injury and/or loss of life to yourself and/or others. All fuel system components **MUST** be located as far from heat sources as possible, like exhaust, engine block,

**WARNING!**



Mechanical and hydraulic lifting devices can tip over or lower accidentally due to incorrect maneuvering or technical errors. A falling object can cause injury and/or loss of life to yourself and/or others. When working under the vehicle, always use stands, and ensure that the ground or floor is stable and level. Never crawl under a vehicle which is only supported by a jack.

**WARNING!**



The fuel system is under pressure. Do not open the fuel system until the pressure has been relieved. Refer to the appropriate vehicle service manual for the procedure and precautions for relieving the fuel system pressure.

**CAUTION!**



When installing this product always wear safety glasses and other appropriate safety apparel. A drilling operation will cause flying metal chips. Flying metal chips can cause eye injury.

**CAUTION:**



Installation of this product requires detailed knowledge of automotive systems and repair procedures. We recommend that this installation be carried out by a qualified automotive technician. Careless installation of this product can result in damage to the product, injury or loss of life to yourself and/or others.

## Compatible Fuels:

Pump Gas  
Race Gas  
E85

This pump assembly is a high-performance factory replacement unit. Key features:

- **Drops directly into the factory fuel tank (NO CUTTING REQUIRED).**
- **Utilizes patented Aeromotive jet siphon in conjunction with factory jet siphon system so it operates just like Ford intended.**
- **High flow pre-filter built into inlet of pump.**
- **Includes fuel level mounting bracket for factory leveling unit.**

**NOTE: The use of Teflon braided line with machine crimped hose ends is recommended. This eliminates the possibility of fuel vapors permeating through the fuel line.**

Maximum continuous operating pressure should not exceed 70 psi.

The enclosed Aeromotive fuel pump utilizes AN-08 ORB (O-ring Boss Port) style outlet port and AN-08 return port; these ports are **NOT PIPE THREAD** and utilize **NO THREAD SEALANT**.

### Aeromotive Related Mod Motor Components:

#### Fuel Filters:

12310 (pump/race gas) 10 micron (A1000)  
12339 (race gas/E85) 10 micron (A1000)  
12341 (race gas/E85) 10 micron (Eliminator, 3.5 and 5.0)  
12305 (filter bracket)

#### Check Valves:

15107 (-10AN)

#### Fuel Pressure Regulators:

13303 (-8 ORB ports) A1000  
13305 (-8 ORB ports) Eliminator  
13134 (-10 ORB ports) 3.5 and 5.0

#### Fuel Pressure Gauge:

15633 (dry 0-100psi)

#### Outlet Cap Port Fittings:

15607 (-8 ORB x -8 AN Male)  
45307 (WRC -8 ORB x -10 AN Male) **Note: This fitting is required if plumbing a -10 feed line from the outlet cap.**

#### Electrical Components:

16307 (30 Amp Pump Wiring Kit) Use with A1000, Eliminator, and 3.5 Pump Modules  
16308 (60 Amp Pump Wiring Kit) Use with 5.0 Pump Module

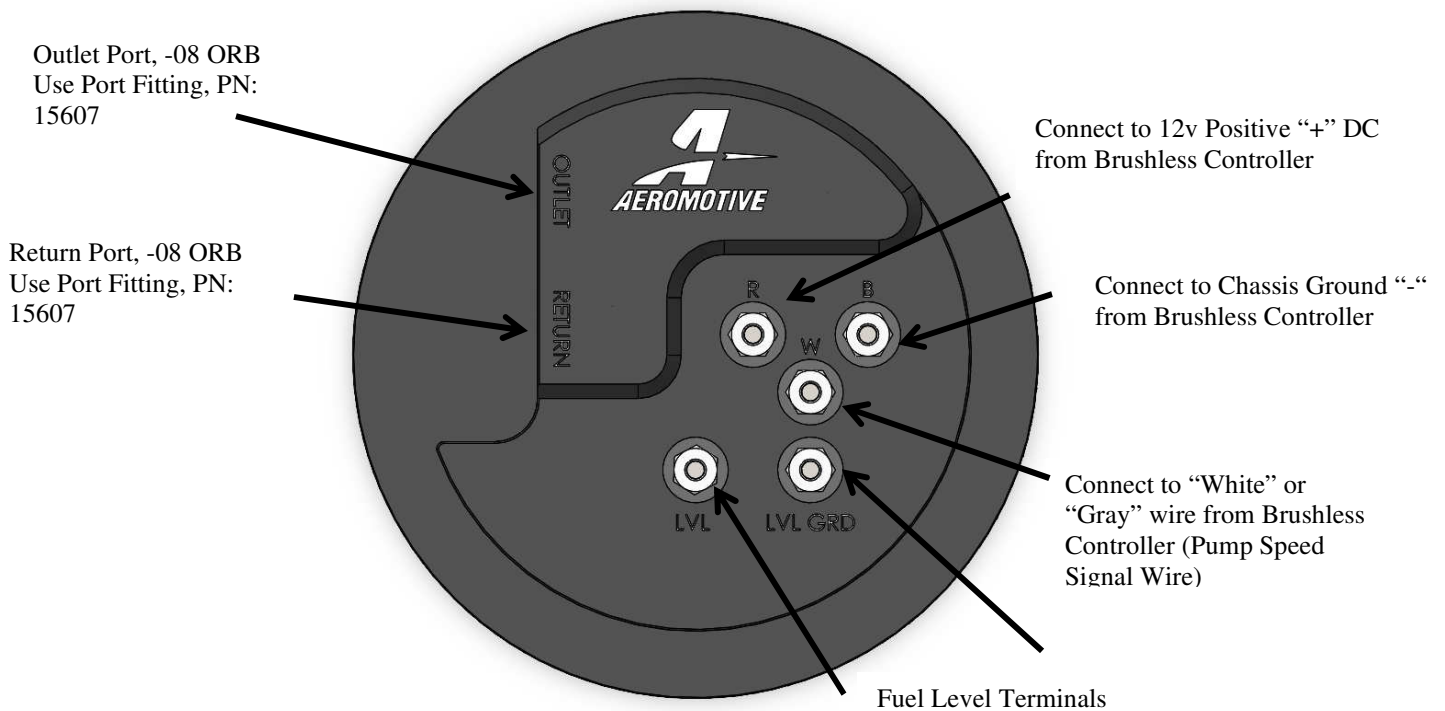

## OUTLET CAP LAYOUT

The following steps are typical of most installations: (Installation of the Pump Module(s) are the same for all Pump Versions (A1000, Eliminator, 3.5, and 5.0 Brushless)).

1. Drain the fuel tank and disconnect the negative battery cable.
2. Raise and support the vehicle.
3. Remove the back seat from vehicle. Do this by pressing forward on the two retention clips underneath the seat cushion with a small screwdriver. You can carefully find them at the edge of the cushion when looking at eye level. When depressed far enough, the seat can be raised and removed easily.
4. Remove black dust plug from driver's side.

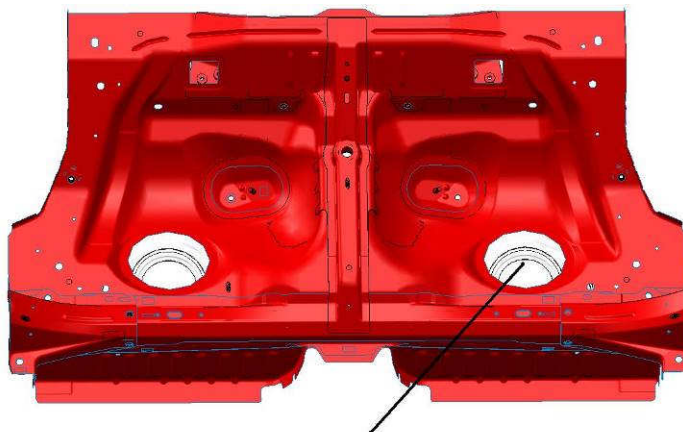

REMOVE BLACK DUST PLUG FROM DRIVERS SIDE FLOOR PAN. DUST PLUG WILL HAVE A WIRING HARNESS PASSING THROUGH IT.

5. Disconnect all electrical connection on the fuel pump top plate and move out of the way.

6. Before removing the factory feed line, relieve system pressure (refer to service manual for proper procedure). Once system pressure has been relieved, disconnect the feed line from top plate.
7. Remove lock ring from top of tank (pump is spring loaded and will pop up when ring is removed).
8. Slowly pull the fuel pump unit up until you see the quick disconnect fitting and tube. Press the tab and pull the line to remove. Pay close attention not to bend the float level arm as you remove the hanger assembly.
9. Once the unit is removed, cover the opening in tank so dirt and debris will not enter the tank.
10. Only one part will be used off the hanger assembly, the fuel level sensor. Carefully remove the fuel level sensor from the OEM pump assembly and set it aside for re-assembly later. Cut the two wires from the fuel level sensor free from the OEM electrical plug, leave as much wire length as possible.
11. Next attach the pump body to the pump outlet cap by threading the pump on the -10 ORB fitting on the bottom of the pump outlet cap. Thread the pump body on until it is tight against the outlet cap fitting.

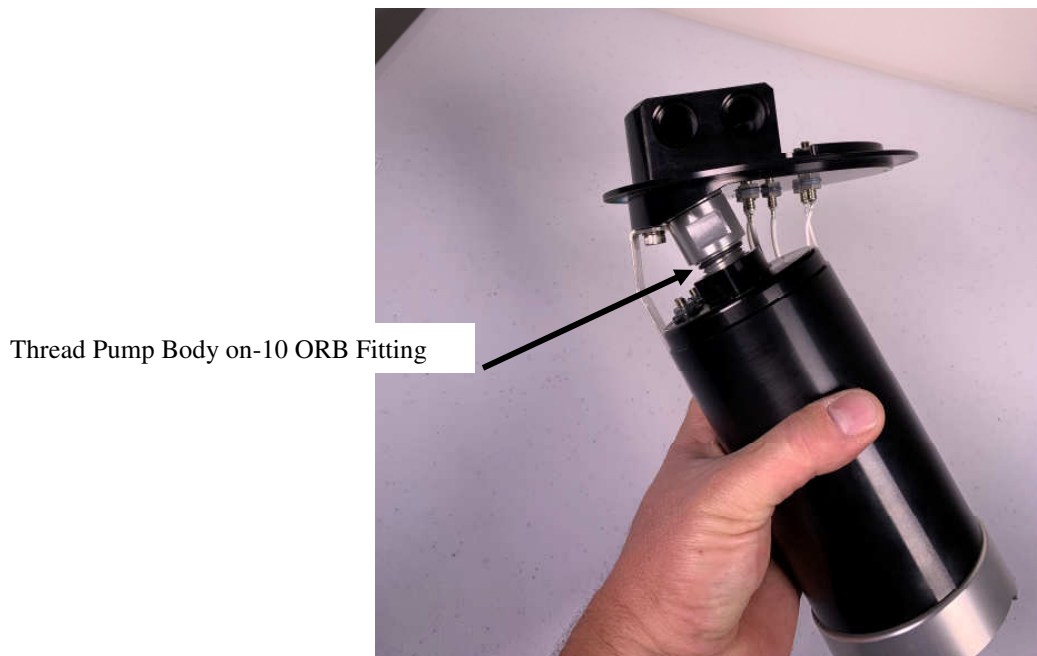
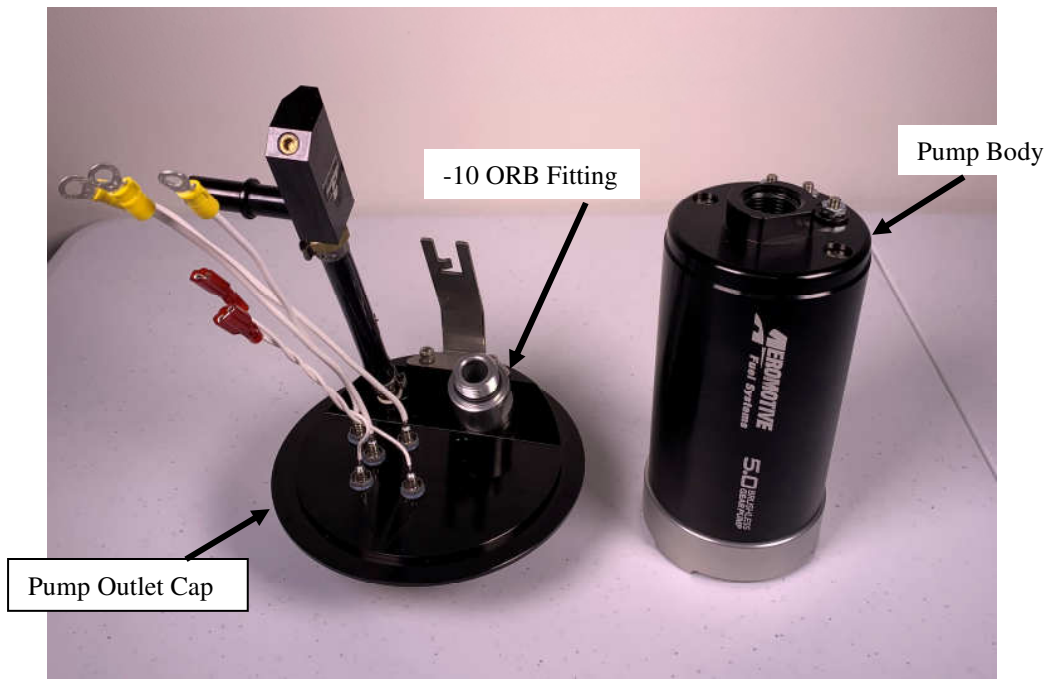

Thread Pump Body on-10 ORB Fitting

12. Once the pump body is threaded onto the -10 ORB fitting, connect the corresponding pump power, ground, and signal wires on the bottom of the outlet cap with the terminals on top of the pump body. The terminals are marked with an engraved letter on the top of the pump body and a laser mark on the top of the outlet cap. Connect "R" to "R", "W" to "W", and "B" to "B" using a small 3/8" wrench. **Note: Connecting the wires to the incorrect terminals will result in severe pump damage and will void the warranty, look twice, connect once!**

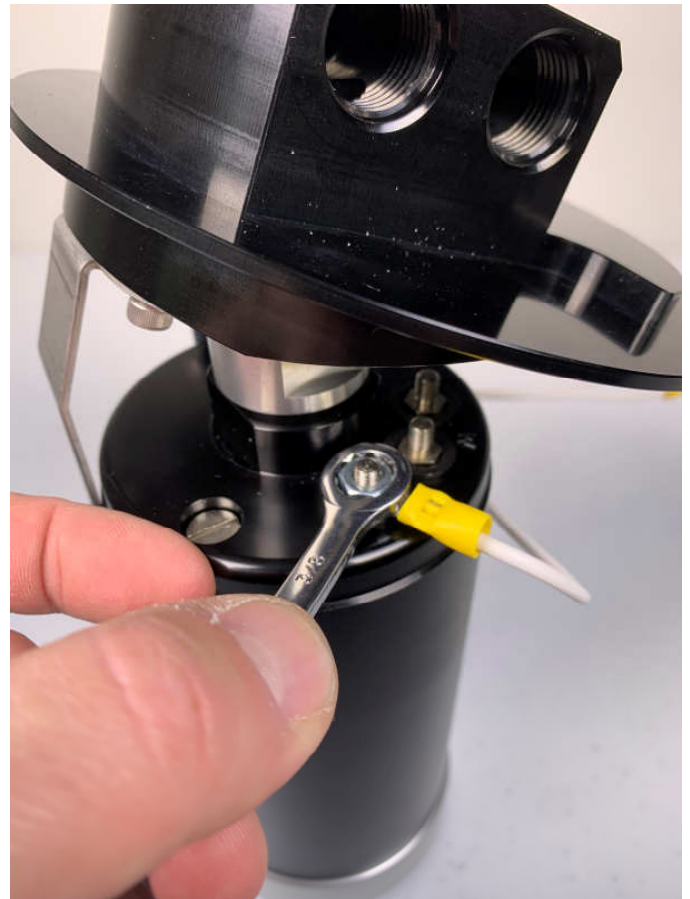

Wires from Outlet Cap properly connected to the Pump Body.

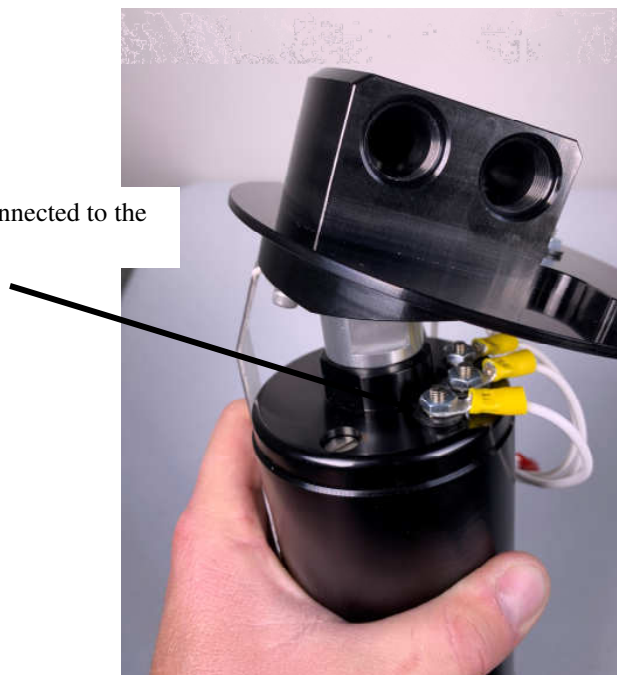

**Note: If you need more access to the terminals when connecting the wires, you can slightly unscrew the pump from the -10 ORB fitting during this step, be sure to re-tighten the pump body after the connections are made!**

13. Next, strip the two wires from the OEM fuel level sensor and crimp the two provided male quick connectors on the wires. Then install the fuel level sensor on the Aeromotive fuel level sensor bracket. To do this, slide the sensor over the bracket as shown in the below pictures, ensure the small plastic retainer clip is retained by the bracket tab. Plug the connectors into the white wires/female quick connectors that are soldered to the bottom of the outlet cap. **NOTE: The sensor is a resistance output only, wiring polarity is bi-directional.**

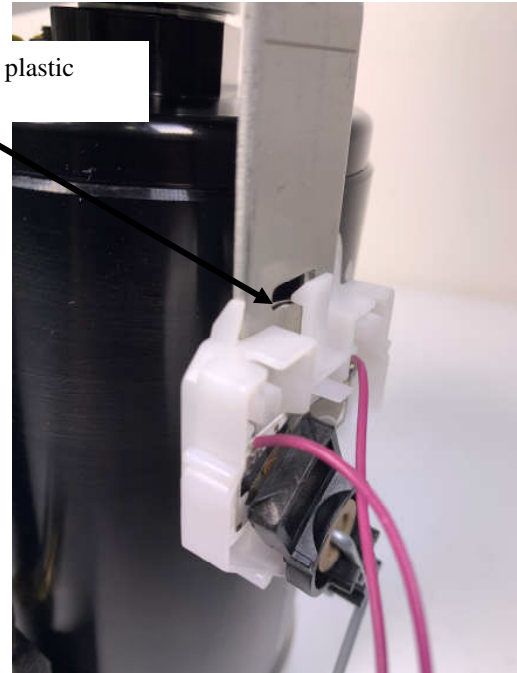
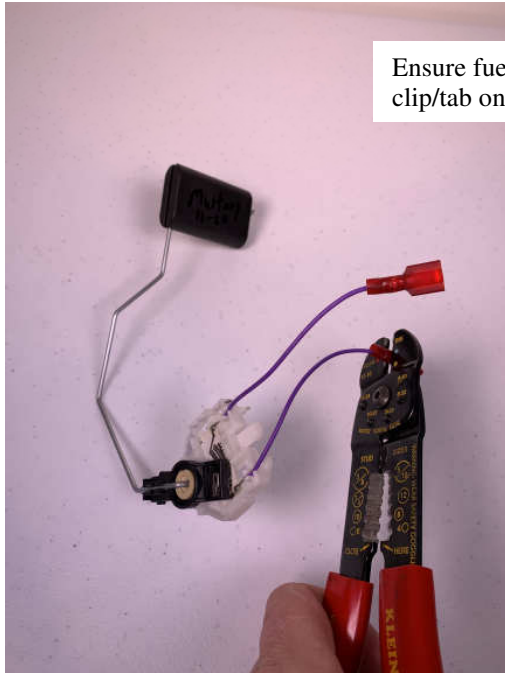

Fuel Level Sensor properly installed on bracket.



14. Next, pull the jet siphon tube up out of the tank and connect it to the Aeromotive Jet Siphon male quick connect. You may have to rotate the quick disconnect on the siphon tube to get it to line up with the Aeromotive Stealth pump.  
**NOTE: While installing the pump assembly, make sure that the siphon tube is routed as to not interfere with the float level sensor. The outlet port(s) will face the driver side when installed.**



15. Before fully inserting your new Aeromotive Stealth fuel pump in your tank, make sure the factory pump seal is clean and positioned correctly. It is highly recommended to install a new factory pump seal (not included) when installing the Aeromotive Stealth fuel pump.

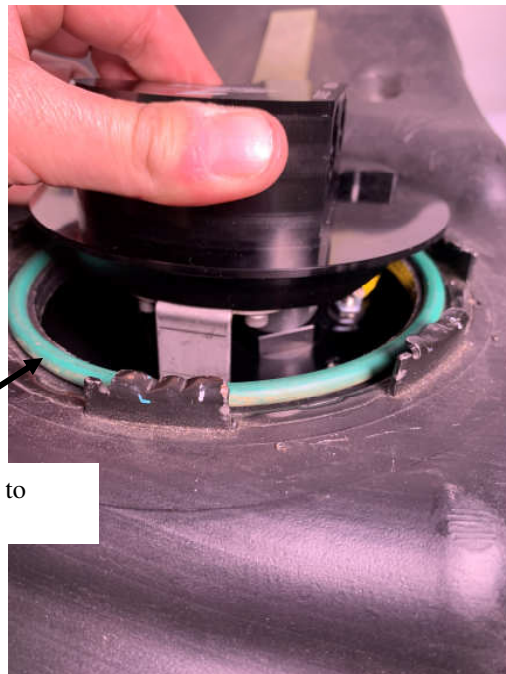

Install new gasket seal (not included) prior to fully inserting pump assembly in tank.

16. Once the pump is in the desired position, install the factory lock ring. **Note: The outlet/return port should be facing the driver's side of the car when installed correctly.**

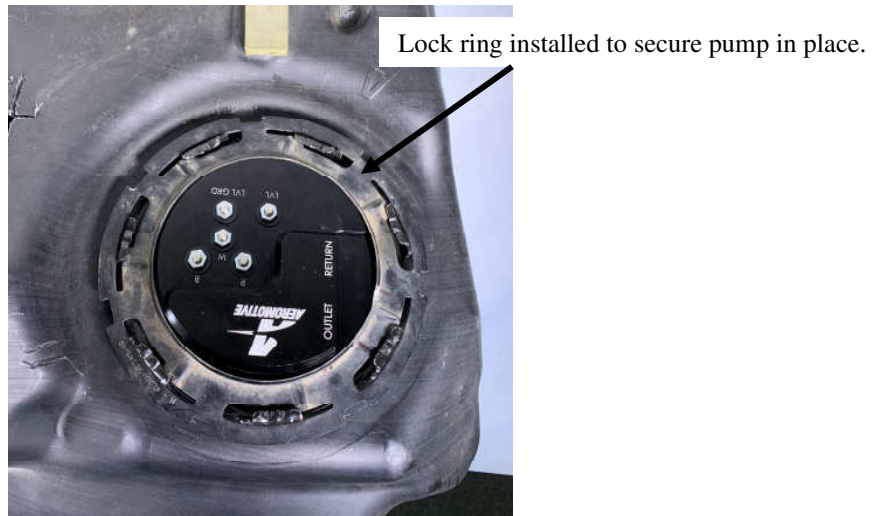

17. Connect the factory fuel level wiring to the Aeromotive fuel level terminals.

**NOTE: You must install a by-pass style regulator (Aeromotive part # 13303 for A1000, 13305 for Eliminator, or 13134 for 3.5 and 5.0) with return line in order for the fuel pump to function correctly. Failure to do so will result in poor performance and fuel pump/system failure.**

18. Feed and return lines need to be plumbed into the vehicle now. It's recommended to run -AN-08 feed for A1000, and AN -10 feed for Eliminator, 3.5, and 5.0 pump assemblies. The return line should be AN-08. Fuel lines should be routed and secured away from moving suspension components and exhaust pipes.

19. The Brushless Aeromotive fuel pump controller requires its own relay and 12V power wire along with a 0-5 volt analog input for the use of the True Variable Speed function. The use of Aeromotive fuel pump wiring kit (part # 16307) is recommended to power the A1000, Eliminator, and 3.5 remote mount brushless pump controller, use (part # 16308) for the 5.0 remote mount brushless pump controller. **Note: Since the factory Ford fuel pump is pulse modulated you CANNOT use the factory fuel pump wires to trigger the relay or the 0-5v input for the True Variable Speed function.**

20. As mentioned above, the Brushless Pump Assemblies are controlled by a remote mount brushless pump controller, which must be installed correctly in order for the pump to function properly. Refer to the following instructions on wiring the brushless controller or refer to the instructions provided with the included controller itself, PN: 180-48A1-0F-01.

21. Determine a suitable location to mount the new controller remote from the pump considering the following:

- a. It is recommended to keep the controller-to-motor lead wire lengths as short as possible for best pump performance.
- b. If desired, motor lead extensions can be used but should be kept as short as possible and lead extensions should be sized large to keep electrical resistance low (you may even want to use a larger size for the extensions than the provided leads for long extensions).
- c. The controller is fully sealed so it can be mounted externally (frame rail, e.g.). The controller sink is designed to be able to handle low air flow so it can also be mounted internally (trunk, e.g.). However, for best results, it is recommended to mount the controller such that it will receive the most and coolest air flow.

When mounting the controller externally and in a location that will likely receive air flow from driving, mount the controller with fins parallel to the airflow and, if possible, upward (not required with sufficient air flow) as in the following image.

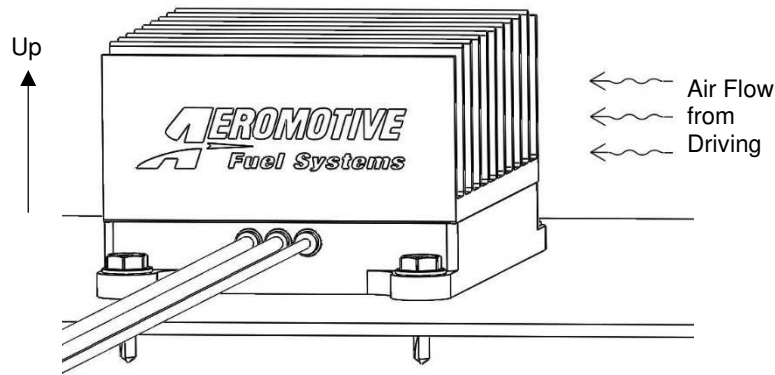

When mounting the controller internally or behind obstructions in a location that will not receive much air flow from driving, mount the controller with the fins vertically as in the following image to achieve the maximum natural convective cooling.

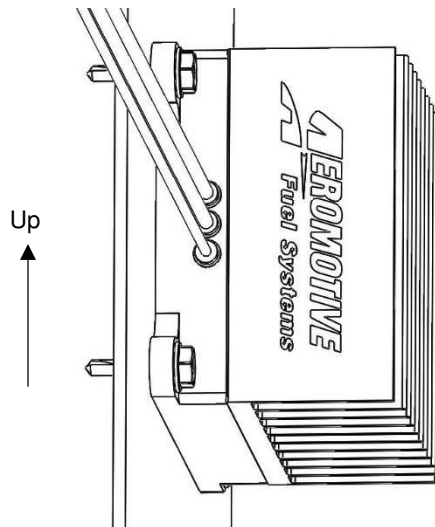

d. **NOTE: THIS CONTROLLER CAN GET HOT** when using full power (60A) continuously with little air flow. **Mount away from locations prone to fuel vapor (e.g., tank vent).**

22. Once a suitable location is found, mount the controller in the recommended orientation using the four #10 self-drilling screws.
23. Crimp the #10 ring terminals to the motor lead wires after cutting to length if not using extensions.
24. Connect the three motor leads from the new controller to the pump matching the colors to the previous wire locations (In most cases, the black lead connects to the "B", red to "R", and white to "W"). Secure connections using the #10-32 nuts, firmly holding the terminal end in place while tightening.

**CAUTION: Ensure that any spilled fuel and any fuel-soaked shop towels are cleaned up and removed from the vicinity of the vehicle before proceeding.**

25. Reconnect power to the new pump controller as shown in the following diagram, +12VDC to the red lead, Ground to the black lead. **NOTE: POWER TO THE PUMP MUST BE FLAT DC, NOT PULSE WIDTH MODULATED!**

**CAUTION: DO NOT REVERSE THE POLARITY-CONNECT AS ABOVE. Reversing the polarity will render the controller inoperable and will void all warranties for this product!**

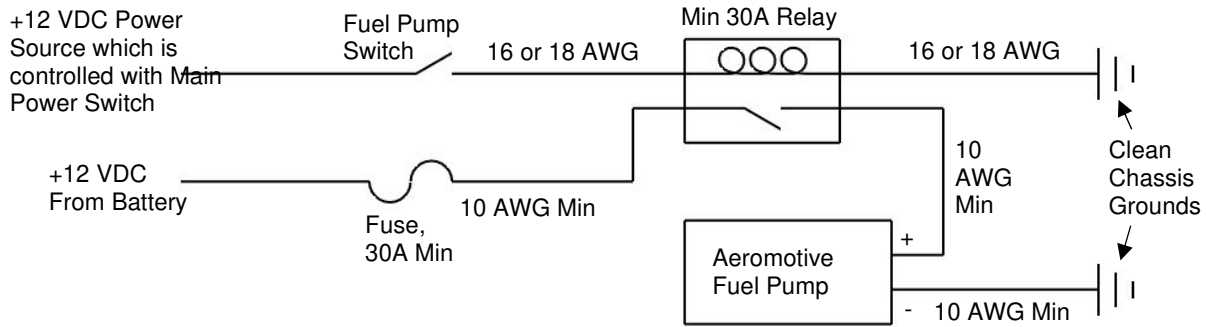

26. This pump controller allows the ability to change the speed of the pump via a 0-5VDC analog input to the yellow signal wire. **THE CONTROL SIGNAL MUST BE A TRUE ANALOG INPUT, NOT PWM.** A PWM signal can only be used if filtered sufficiently for smooth operation. The signal wire used to control the speed of the pump may be connected in ONE of multiple configuration examples as shown in the following illustrations to control the speed of the pump.
27. This pump controller has a minimum floor for pump speed of approximately 40% depending on the pump. This means that fuel pump speed will not fall below 40% of full speed with zero input voltage on the yellow control signal wire.
28. This pump controller has a minimum voltage threshold of approximately 0.5VDC. Voltage above 0.5VDC on the yellow input wire will increase the speed of the pump. Signal input of voltage below 0.5VDC will have no effect on pump speed. This ensures allowance for minimum, closed throttle TPS settings of up to 0.5VDC without affecting fuel pump speed at idle.
29. This pump controller has a full pump speed voltage threshold of approximately 3.7VDC, where the full pump speed will be achieved with signal input voltage at or above 3.7VDC and above which no further change in pump speed will occur. This ensures that when a TPS signal is used to drive pump speed that typical throttle openings of 70-75% and higher will ensure full fuel pump volume is delivered to the fuel rail or carburetor. Voltage between 0.5VDC and 3.7VDC will vary the speed of the fuel pump according to the voltage applied.

**CONTROL CONFIGURATIONS:**

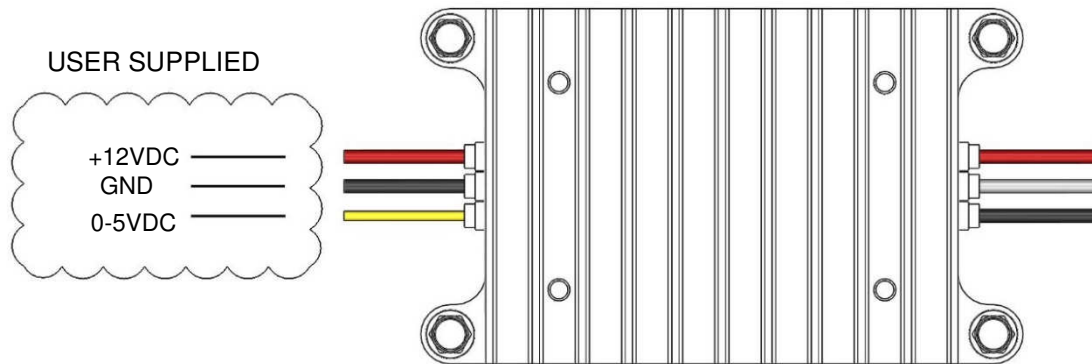

MODE 1 – TPS or Other 0-5VDC Input Control

Aeromotive recommends the “Mode 1” control method where the 0-5VDC signal input is tied to a Throttle Position Sensor using the output wire to the ECU. The intent for this control is to reduce the fuel pump output (and thus the amount of returned fuel flow) during low throttle opening (low engine demand) to reduce excess recycling of fuel to help keep fuel tank temperatures low. Alternatively, other 0-5VDC analog output sensors (some MAF sensors, a 2 or 3-Bar MAP sensor, etc.) or voltage dividing/regulating/switching components may be used. It is the customer’s responsibility to ensure a signal supply and control strategy where the fuel flow is sufficient to meet engine demand.

If no signal supply is suitable or desired, the controller can still be wired for use as in Modes 2 – 4, as shown following, to allow different fuel pump speed and flow outputs from the pump.

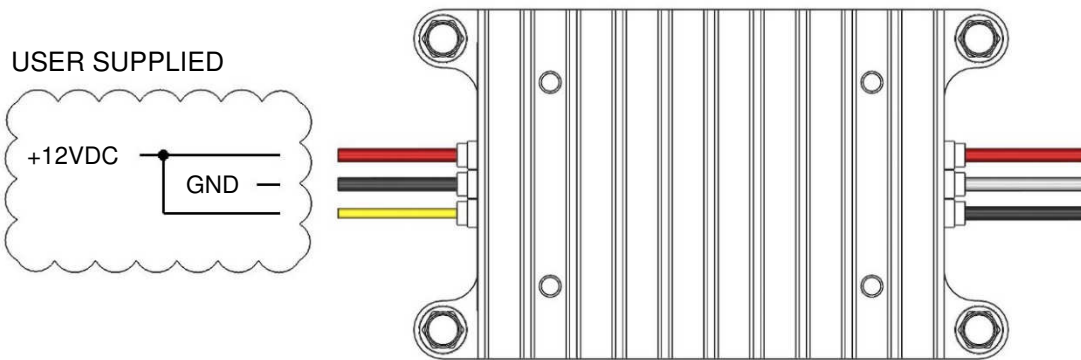

MODE 2 – Constant Full Speed

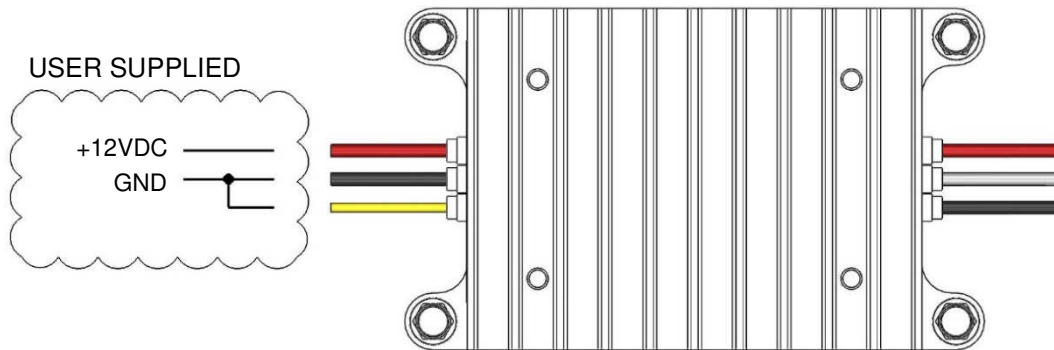

MODE 3 – Constant Low Speed

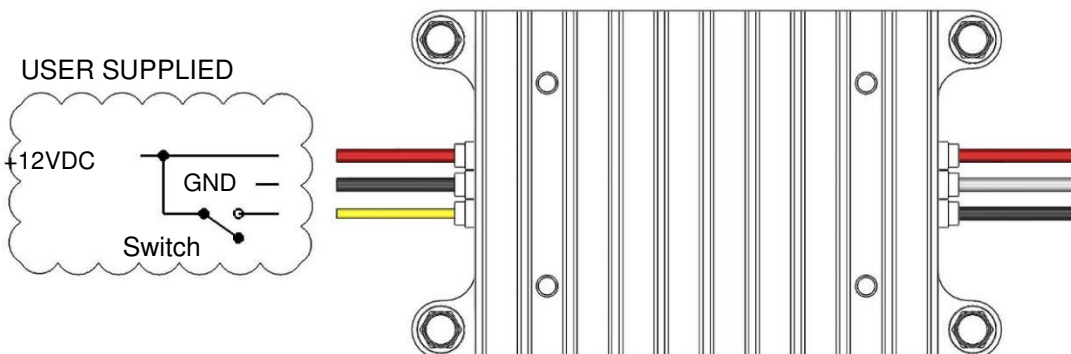

MODE 4 – Switched Speed On - Demand from Low to High

Mode 4 can be activated by any relay or switch providing 5VDC or higher (system voltage up to 19VDC is fine) to the control wire. A relay for this purpose could be activated using the programmable output from a tunable ECU, or via a boost Hobb's or WOT switch connected to 12VDC to name a few examples.

30. After all wire connections are made, attach a suitable fuel pressure gauge to the fuel system Schrader valve, fuel rail or fuel pressure regulator test port. Examples:  
 Aeromotive P/N **15632** 0-15 PSI (1 1/2") Fuel Pressure Gauge  
 Aeromotive P/N **15633** 0-100 PSI (1 1/2") Fuel Pressure Gauge

**Ensure that any spilled fuel and any fuel-soaked shop towels are cleaned up and removed from the vicinity of the vehicle.**

**CAUTION: While performing the following steps, if any fuel leaks are detected, immediately turn the ignition to OFF, remove any spilled fuel and repair the leak(s) before proceeding!**

31. Turn the ignition to ON **without starting the engine**, allow the pump to run for several seconds and check the fuel pressure. If there is no pressure, turn the ignition to OFF, wait one minute, then turn the ignition to ON and recheck the pressure. Repeat this ignition OFF and ON procedure until the gauge registers pressure or you detect a fuel

leak. If no pressure is registered on the gauge after running the pump for several seconds and you have found no leaks, check all fuel and electrical connections to determine the cause. IF THE PUMP IS RUNNING BACKWARDS, REPEAT THE ABOVE STEPS SWITCHING ANY OF THE TWO **MOTOR LEAD WIRES** FROM STEP 21, then reconnect and retest the pump.

**CAUTION: DO NOT REVERSE THE TWO POWER LEADS EXTERNAL TO THE CAP! Reversing the polarity of the main power and ground wires going into the controller will render the controller inoperable and will void all warranties for this product!**

32. Once the fuel pressure gauge registers pressure, start the engine. If you have installed an adjustable fuel pressure regulator, switch the pump to full speed and adjust fuel pressure to the desired setting.

Test-drive the vehicle to insure proper operation and re-check the fuel system for leaks. **If any leaks are found, immediately discontinue use of the vehicle and repair the leak(s)!**

## ***Contact Us***

RGA NUMBER REQUIRED FOR ALL RETURNS TO AEROMOTIVE.

To obtain an RGA number, please call (913) 647-7300 and ask for the Returns and Repairs department or complete the online form under the "Rebuilds" section at [www.aeromotiveinc.com](http://www.aeromotiveinc.com) .

- **Shipping & Returns**  
Aeromotive Inc.  
11414 W 79th Street.  
Lenexa, KS 66214

**General Inquiries and Tech Line:** (913) 647-7300

**General Email:** [info@aeromotiveinc.com](mailto:info@aeromotiveinc.com)

**Tech Email:** [tech@aeromotiveinc.com](mailto:tech@aeromotiveinc.com)

*The Aeromotive Tech Lines are open Monday through Friday from 9:30AM to 5:00PM Central Standard Time.*



**WARNING:** This product can expose you to chemicals, including chromium, which is known to the State of California to cause cancer or birth defects or other reproductive harm. For more information, visit: [www.p65Warnings.ca.gov](http://www.p65Warnings.ca.gov)

### ***AEROMOTIVE, INC. LIMITED WARRANTY***

This Aeromotive Product, with proof of purchase dated on or after January 1, 2003, is warranted to be free from defects in materials and workmanship for a period of one year from the original date of purchase. No warranty claim will be valid without authentic, dated proof of purchase.

This warranty is to the original retail purchaser and none other and is available directly from Aeromotive and not through any point of distribution or purchase.

If a defect is suspected, the retail purchaser must contact Aeromotive directly to discuss the problem, possible solutions and obtain a Return Goods Authorization (RGA), if deemed necessary by the company. Please call 913-647-7300 and dial option 3 for the technical service dept. All returns must be shipped freight pre-paid to the company and with valid RGA before they will be processed.

Aeromotive will examine any product returned with the proper authorization to determine if the failure resulted from a defect or from abuse, improper installation, misapplication or alteration. Aeromotive will then, at it's sole discretion, return, repair or replace the product.

If any Aeromotive product is determined defective, buyer's exclusive remedy is limited in value to the sale price of the good. In no event shall Aeromotive be liable for incidental or consequential damages.

Aeromotive expressly retains the right to make changes and improvements in any product it manufactures and sells at any time. These changes and improvements may be made without notice at any time and without any obligation to change the catalogs or printed materials.

Aeromotive expressly retains the right to discontinue at any time and without notice any Aeromotive product that it manufactures or sells.

This warranty is limited and expressly limits any implied warranty to one year from the date of the original retail purchase on all Aeromotive products.

No person, party or corporate entity other than Aeromotive shall have the right to: determine whether or not this Limited Warranty is applicable to any Aeromotive product, authorize any action whatsoever under the terms and conditions of this Limited Warranty, assume any obligation or liability of any nature whatsoever on behalf of Aeromotive under the terms and conditions of this Limited Warranty.

This Limited Warranty covers only the product itself and not the cost of installation or removal.

This Limited Warranty is in lieu of and expressly excludes any and all other warranties, expressed or implied. This Limited Warranty gives you specific legal rights, and you may also have other rights which vary from state to state.