

Top Street Performance's HEI Distributor has everything you need, all under one cap. With a high-quality aluminum housing and hardened steel dual bushing construction, it is built to last. It features fully adjustable mechanical and vacuum advances, meaning precision is a breeze. It has a high-output module, high-spark 65,000-volt coil, solid brass terminals, and an easy one-wire hookup.

Parts Included:

- (1) HEI Distributor
- (1) Vacuum Advance Hex Key

DISTRIBUTOR INSTALLATION :

1. Place the engine in TDC, the rotor should be pointing to the number one cylinder. Top Dead Center is when the #1 cylinder is at the furthest point of travel before it changes to the downward stroke.
2. Disconnect the wiring from the distributor.
3. Loosen the distributor hold down clamp and slide the clamp out of the way.
4. Lift the distributor out of the engine. Note that the rotor rotates as you lift the distributor out. This is due to the helical cut gear and should be taken into consideration when installing the new distributor.
5. Install the gasket and apply a liberal amount of lubricant to the distributor gear.
6. Install the new distributor. The terminal that the rotor is pointing too will be the new number one cylinder. Removing the distributor, rotating the gear, and reinstalling can change the location of the number one terminal.
7. Install the distributor cap and sparkplug wires one at a time to ensure correct location. A wire retainer is supplied to secure the wires in place.

JM6500CB

HEI Distributor 2-Piece Power & Tachometer Cables

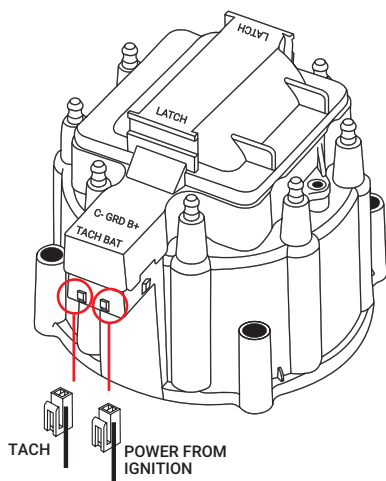
**JM6933**

HEI Distributor One-Piece Power & Tachometer Pigtail

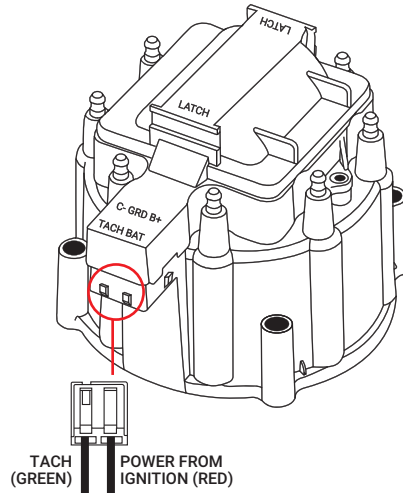

IF HOOKING UP TO 6AL BOX, SEE BELOW:

NOTE: The GM Ignition Module and condenser are removed and replaced with the JM6934 Harness.

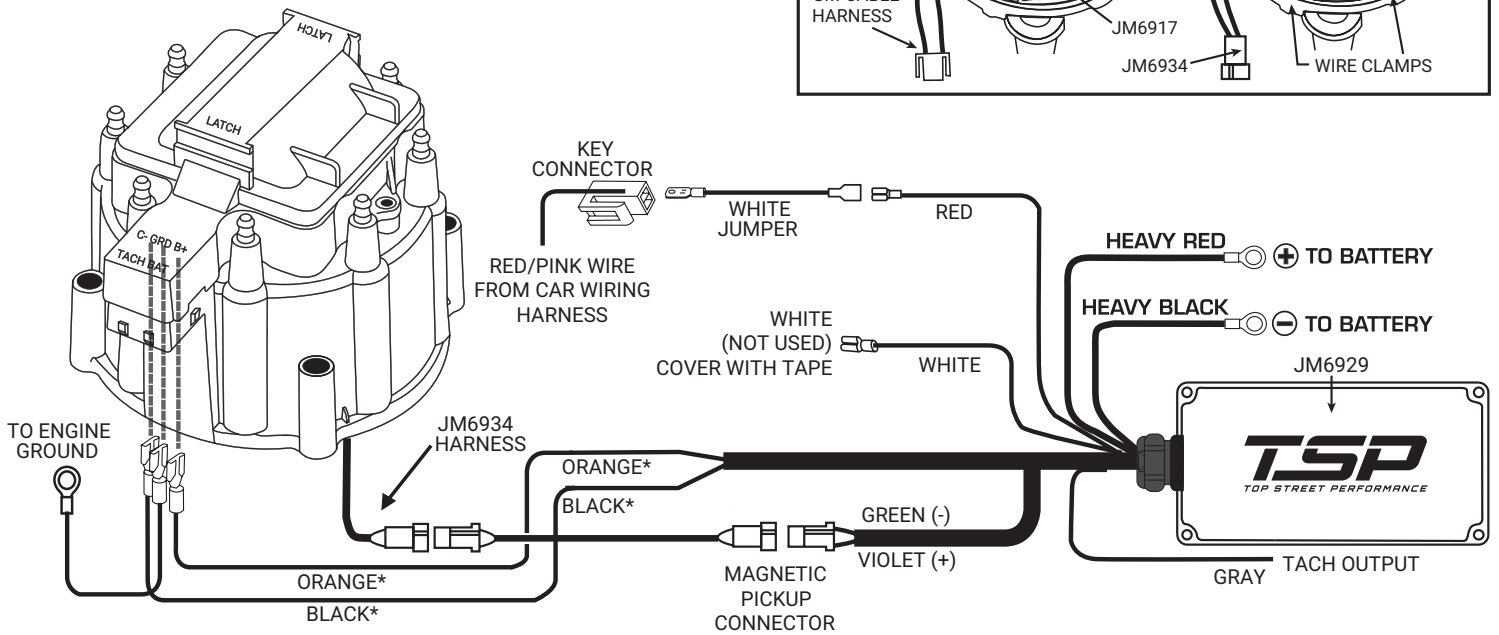
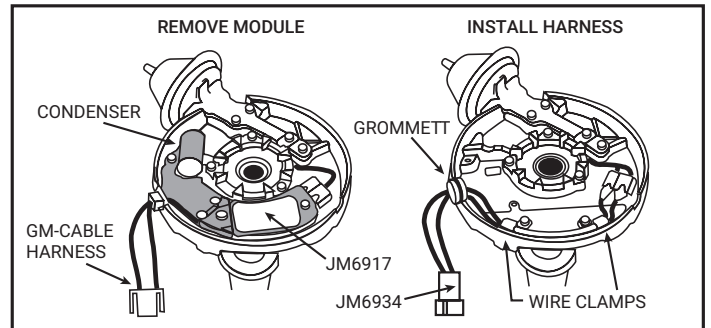

***ORANGE - CONNECTS TO B+**
***BLACK - CONNECTS TO C-**