

G-Comp Universal Suspension Kits

A high-performance suspension for whatever you're building. There's a reason you see classics like Camaros, Chevelles, and C10 trucks at just about every car show or cruise night. They're beautiful cars that are plentiful and have a ton of aftermarket support to make them faster and handle better. But what about the rest of us? For every one of those popular platforms there are a bunch of cool classics that just need a little improvement in the suspension department to make them into fun, modern performance cars. Those are the cars we had in mind when we developed the G-Comp Universal Front Suspension Kit.

350-2000-54

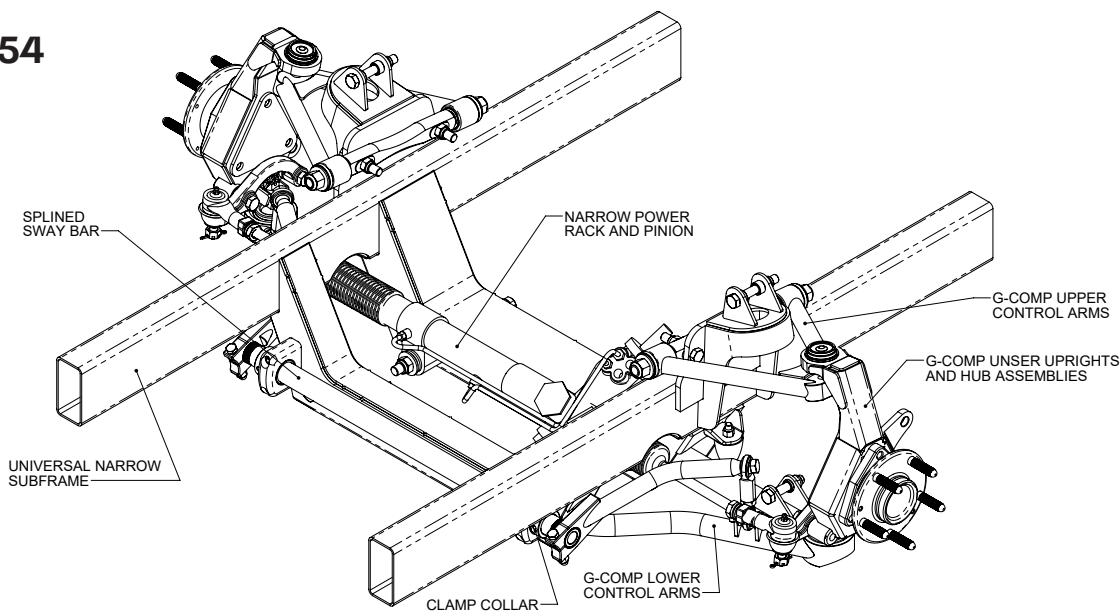

350-2000-56, 350-2000-58, 350-2000-60 and 350-2000-62

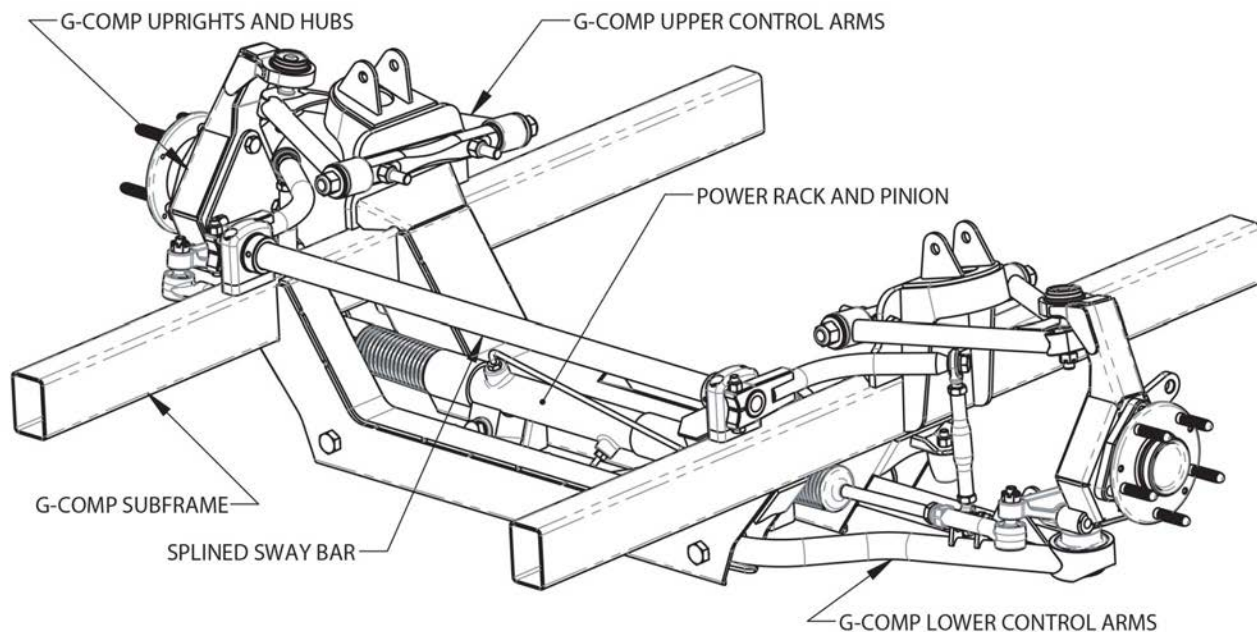

INSTRUCTIONS

© 2025, Speedway Motors, Inc.

SPEEDWAY
motors®

350-2000-54 - Universal G-Comp Suspension

Kit Contents		
Qty	Part #	Description
1	350-2000.7	Subframe Weldment
1	350-203	Upper Arms
1	350-204	Lower Arms
1	350-1100	Uprights
1	910-35345	Power Rack and Pinion
1	350-2000.7.8	Sway Bar Kit
1	350-2000.7.12	Hardware Kit
2	910-34316-MAN	Tie Rod End
1	350-2000.7.13	Steering Arms - Pair
1	350-100.2	Camber Shims
2	350-350	Corvette Bearings

This kit is designed as a performance upgrade to the OEM suspension system in almost any vehicle. This installation will involve fabrication and welding to connect the new subframe weldment to the existing structure of the vehicle. As such, this should only be attempted by an experienced fabricator familiar with this type of work.

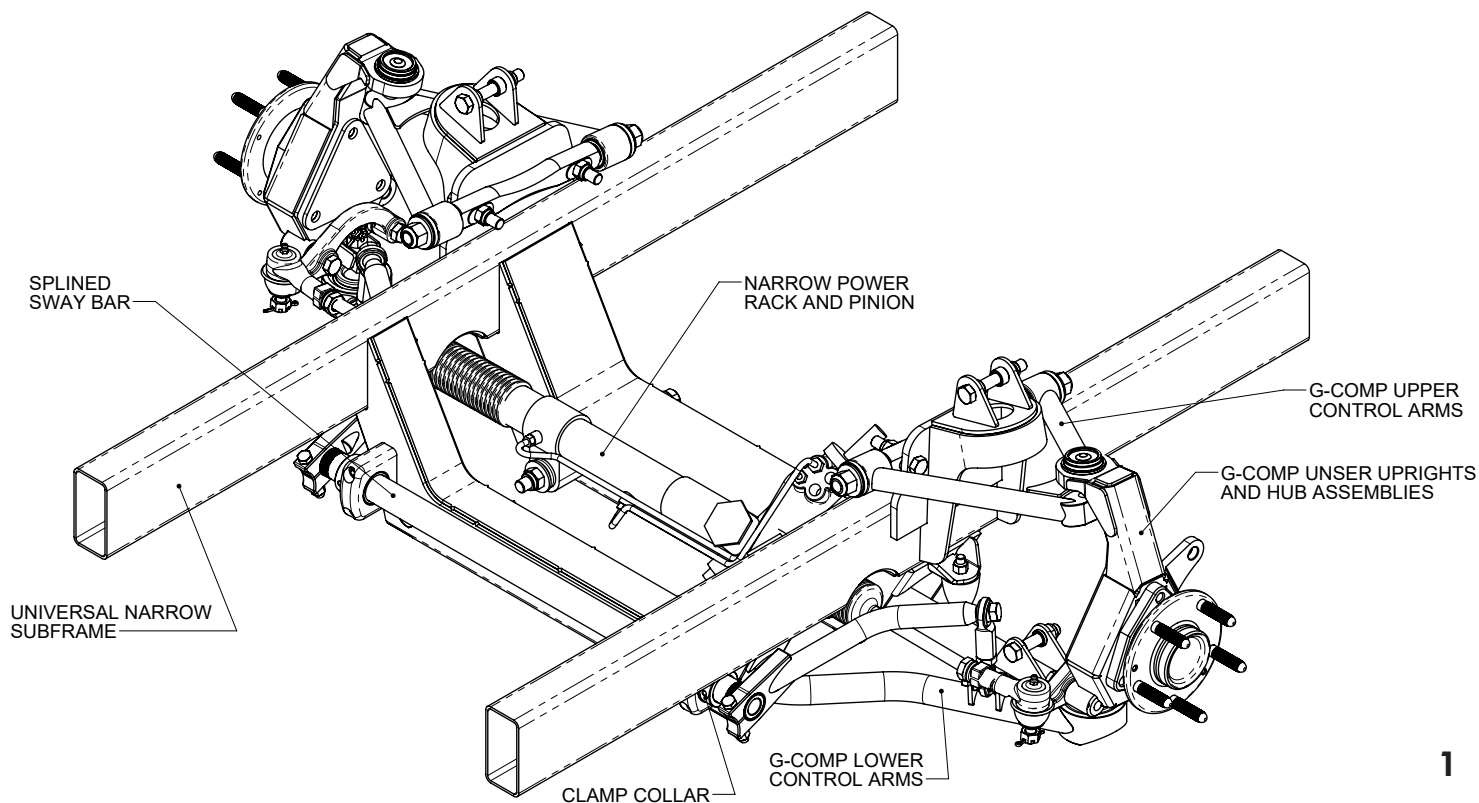

INSTRUCTIONS

© 2025, Speedway Motors, Inc.

SPEEDWAY
motors®

Please read and understand these instructions completely BEFORE starting this project.

To start, determine desired ride height based on the tire size you will be using. The axle centerline for this suspension is 1-1/4" above the lower surface of the frame rail at designed ride height and 26-3/8" back from the front edge of the subframe rail. **NOTE:** This 26-3/8" dimension will vary slightly depending on how much caster you put in the suspension - more caster will move the centerline back. Based on this, calculate the frame rail height dimension. For example: (see illustration) if the proposed tire diameter is 28", then the centerline of the tire (spindle centerline) would be 14" (28"/2) above ground level. Subtracting the 1-1/4" from the 14" leaves the lower surface of the rail at 12-3/4" above the ground. Now, substitute your desired tire diameter into this formula to calculate your frame rail height. Mock the vehicle up at your desired ride height and determine the best way to attach the subframe weldment to the existing structure of the vehicle while maintaining this relationship. In the case of a full frame car, cutting the existing frame near the firewall and fabricating a 2x4, 2x3 or similar tube rail to attach the subframe to the existing structure is an option. Depending on the condition of the existing frame or plans for the rear suspension, it may also be easier and better to fabricate an entirely new full frame. On unibody type vehicles, the job can be a bit tougher and require a bit more engineering as these vehicles have no real frame rail to start with. It is up to the fabricator to determine the best method to use and to ensure that the completed chassis is structurally rigid enough to handle the input loads that will occur as the vehicle is driven. If you are inexperienced in this type of fabrication, it is highly recommended that you seek the assistance of a professional shop that has experience in this area.

Steering Rack. This G-comp front suspension kit is designed to use a specially built narrow rack and pinion. Install the steering rack as shown, using the two 9/16"-18 x 9" bolts, washers and lock nuts through the sleeves in the main cradle. The bolts will come in from the rear of the cradle.

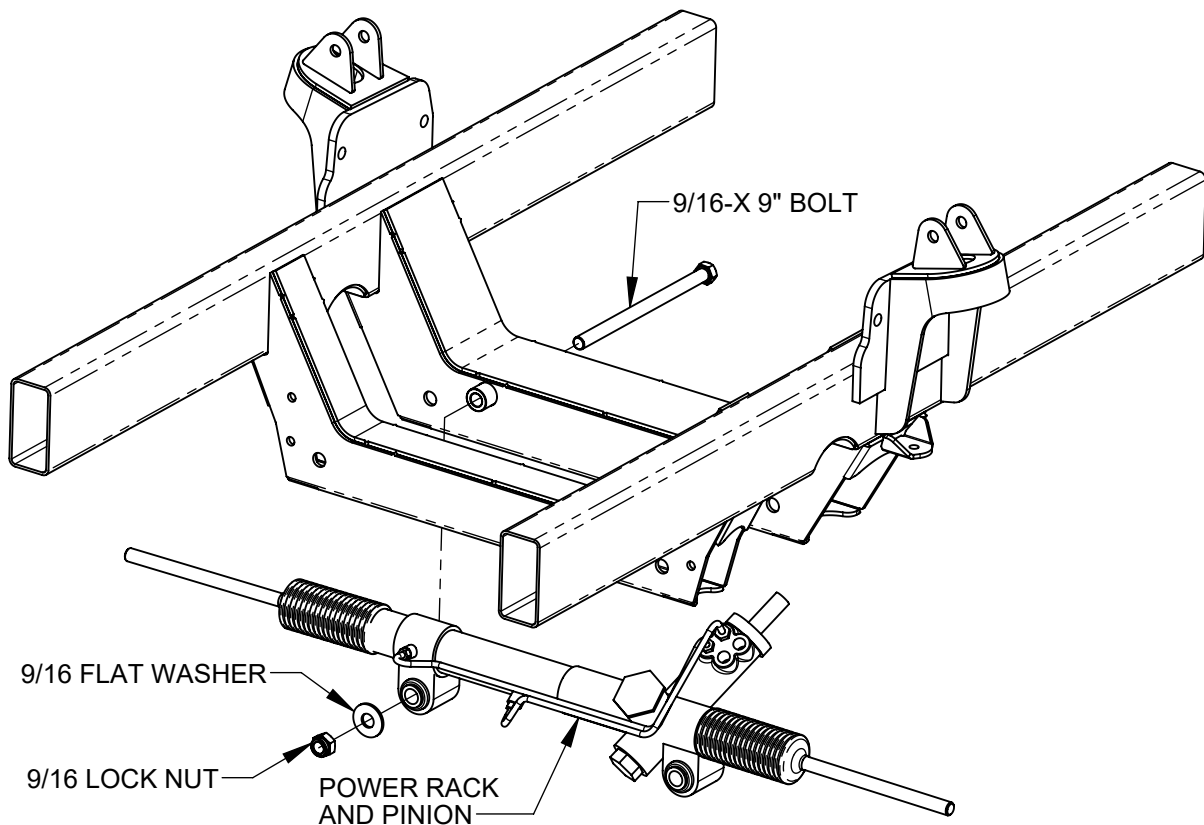

INSTRUCTIONS

© 2025, Speedway Motors, Inc.

SPEEDWAY
motors®

Install the lower control arms into the crossmember. Align the control arm bushings with the lower control arm holes in the cross-member. The front bolts, 5/8"-18 x 3-1/4" are to be installed from the front side. The rear bolts, 5/8"-18 x 5-1/2" are to be installed from the rear. Install the 5/8"-18 lock nuts and tighten. Install the lower control arm bump stops to the sub-frame using the supplied 3/8" lock nuts as shown.

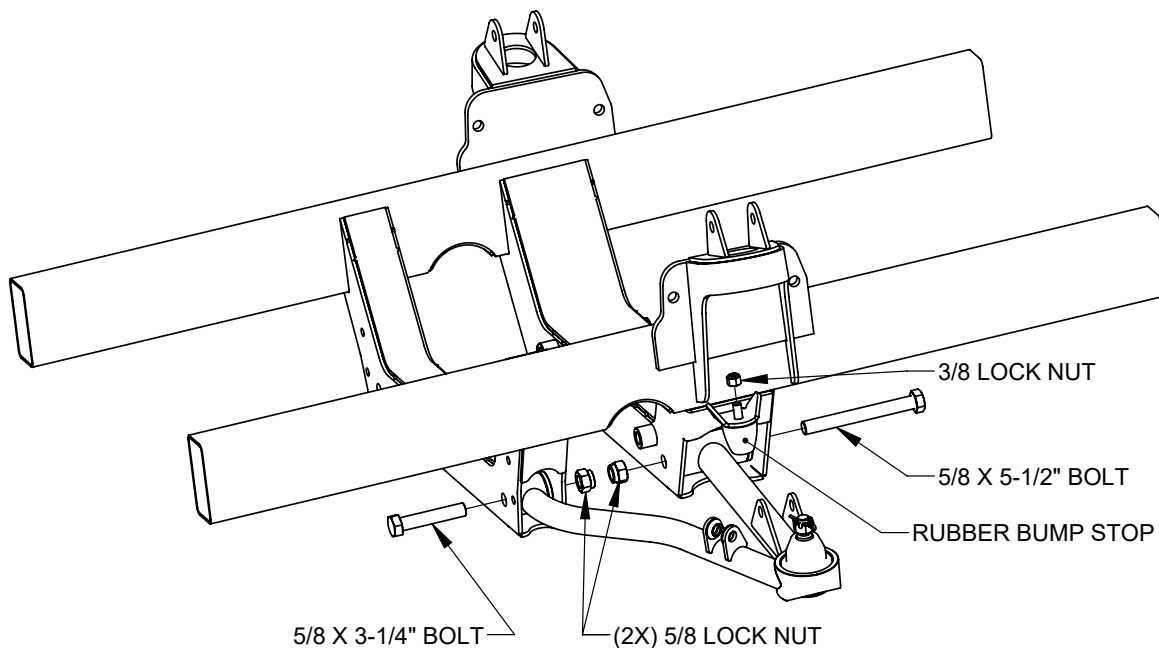

Install the shocks. This procedure may vary slightly depending on the shocks used. Spin the adjusting collar onto the threaded shock body. Adjust the collar all the way to the bottom of the threads. Install the spring over the shock body.

NOTE: The G-Comp sub-frame has the upper spring seat built into the sub-frame, so the upper coil-over shock spring retainer cone is not used. Using the 1/2"-20 x 2-1/2" bolt and two 3/16" wide spacers, install the shock into the lower mount on the control arm. Secure it with a 1/2"-20 lock nut. Fully extend the shock and raise the lower arm so the upper shock mount and spring align with the shock mount and spring pocket on the sub-frame. Install the 1/2"-20 x 3" upper shock bolts and 7/16" wide spacers. Secure it with a 1/2"-20 lock nut.

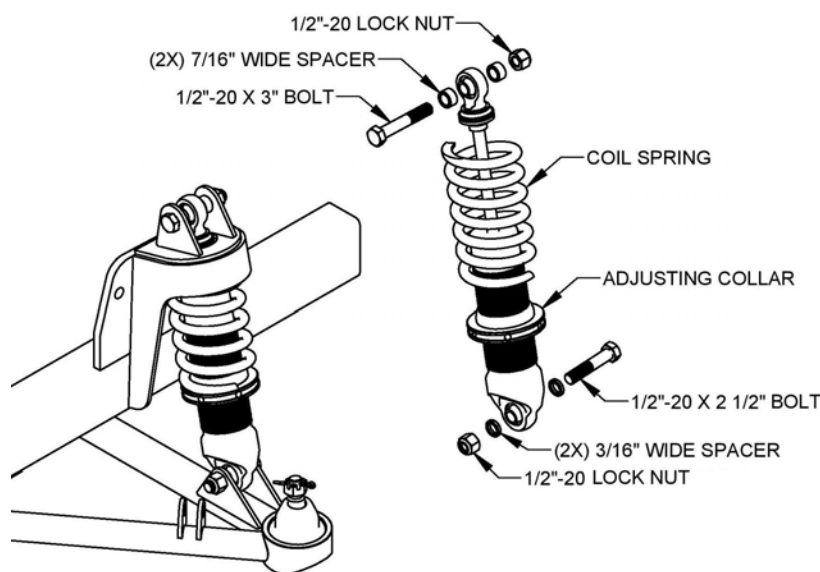

NOTE: This kit is designed to use shocks with a compressed length of 10" and an extended length of 14". Shock ends should be 1/2" bearings with a mounting width of 1". For recommended part numbers, please visit our **3** website or contact one of our tech experts.

INSTRUCTIONS

© 2025, Speedway Motors, Inc.

SPEEDWAY
motors®

Mount the upper control arms to the sub-frame using the 1/2"-20 x 2-3/4" bolts and lock nuts. The optional 3" long bolts (included) are to be used if needed for more negative camber. Rotate the cross shafts so the caster insert pockets are facing toward the center of the vehicle. Install the bolts through the caster inserts, cross shafts, and the sub-frame as shown. Then secure with the 1/2"-20 locknuts. For initial installation, install the #2 caster insert with the hole positioned to the front of the pocket. This should give a good initial starting point for alignment.

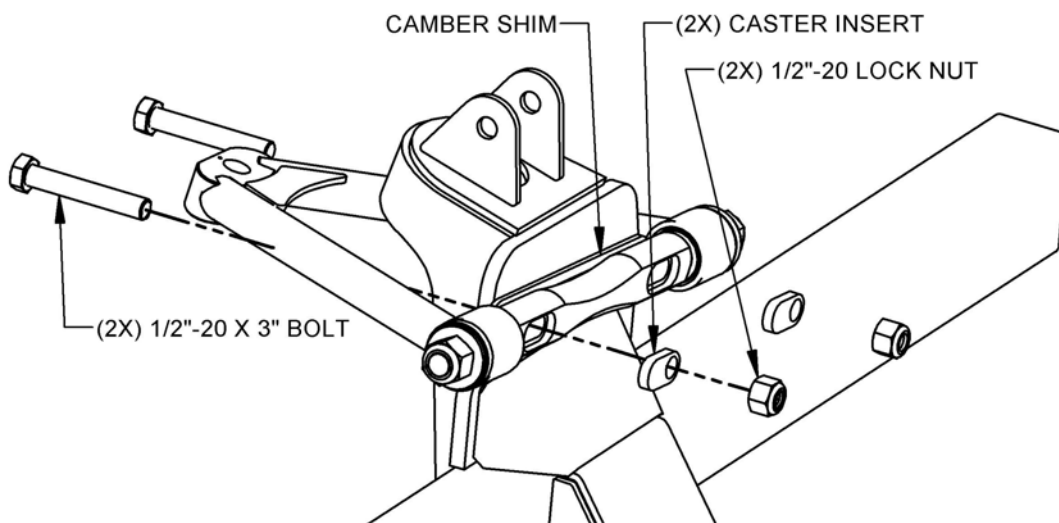

Install the uprights and steering arms. Install the upright onto the lower ball joint and fasten with the supplied castle nut. Repeat with the upper ball joint and install the cotter pins. Bolt the steering arms to the spindles using the 1/2"-20 x 1-3/4" bolts. **NOTE:** Loctite or similar thread locker should be used on these threads.

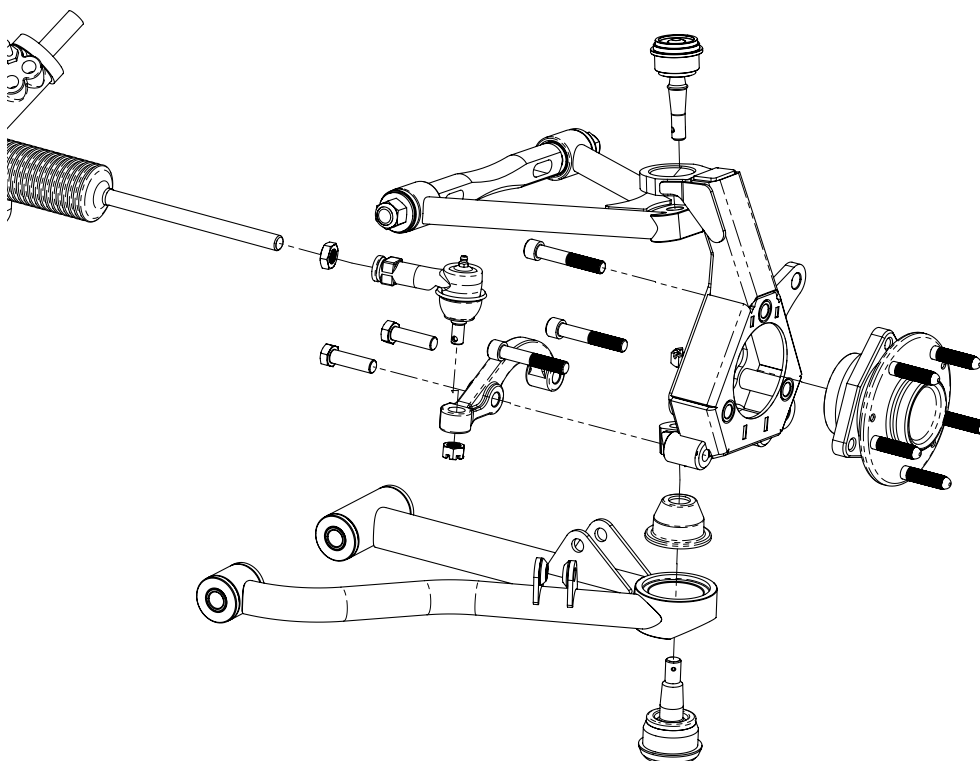

INSTRUCTIONS

© 2025, Speedway Motors, Inc.

SPEEDWAY
motors®

Install the hubs:

The Corvette style hubs included with this kit use metric hardware, including metric lug nuts. Using the supplied M12 metric bolts and Loctite or similar thread locker, secure the hubs to the uprights. The fit of the hub into the upright is a close tolerance fit and it may be required to remove any paint or powder coating from the inner bore of the upright before assembly.

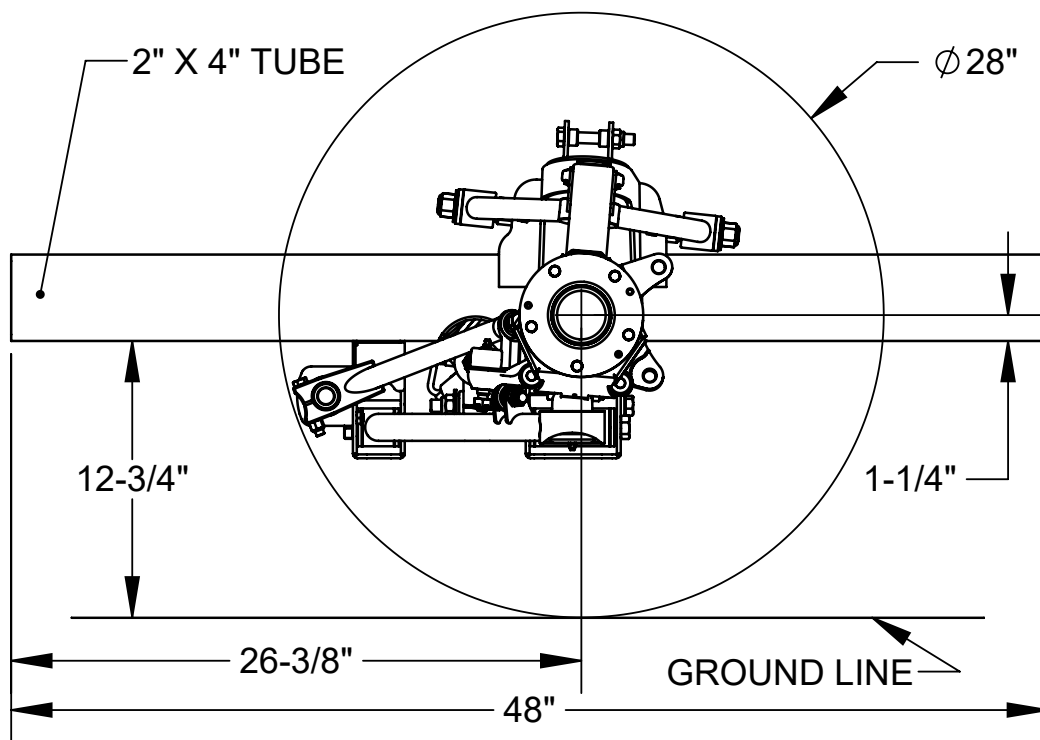

Install the outer tie rod ends and jam nuts onto the inner tie rods of the rack. Thread both tie rod ends on equally. Attach the tie rod ends to the steering arms using the castle nuts supplied with the tie rod ends. Tighten and install the cotter pins. Final alignment will be done after the vehicle is complete and set on the ground.

INSTRUCTIONS

© 2025, Speedway Motors, Inc.

SPEEDWAY
motors®

Sway bar assembly:

Press the bushings into the aluminum pillow-blocks and install the pillow-blocks to the front cross member with the bushing shoulder to the outside. Mount the pillow blocks to the face of the front cradle as shown using the four 3/8"-24 x 2-1/4" socket head cap screws and 3/8"-24 thin lock nuts. Slide the sway bar through the bushings, installing the two clamp collars to the outside of both pillow blocks. Tighten the 3/8" cap screws holding the pillow blocks. Center the sway bar between the pillow blocks. Slide one clamp collar up against the bushing shoulder in the pillow block and tighten the set screw. Slide the second clamp collar up to the opposite bushing in the pillow block leaving about .075" of side clearance between the clamp collar and the bushing. A nickel is about .075" thick and can be used as a spacer between the clamp collar and the bushing to provide the proper side clearance. Tighten the clamp collar set screw. Assemble the sway bar links as shown, leaving roughly 1/4" of threads showing. Slide the sway bar arms onto the splined ends of the sway bar aligning them flush with the end of the bar. Make sure they are parallel or "clocked" to one another then tighten the 3/8"-24 x 2-1/2" pinch bolts and lock nuts. Slide the 1/2"-20 x 1-1/4" bolts through the female rod end joints and thread them into either end of the sway bar arms making sure to use Loctite on the threads. Mount one of the lower links into the bracket on the lower control arm using a 1/2"-20 x 2-1/4" bolt and secure it with the 1/2"-20 lock nut. Leave the bolt out of the lower link on one side at this time. The second bolt and nut will be installed after the ride height is set and the car is set on level ground. This will ensure that there is no preload on the sway bar at ride height.

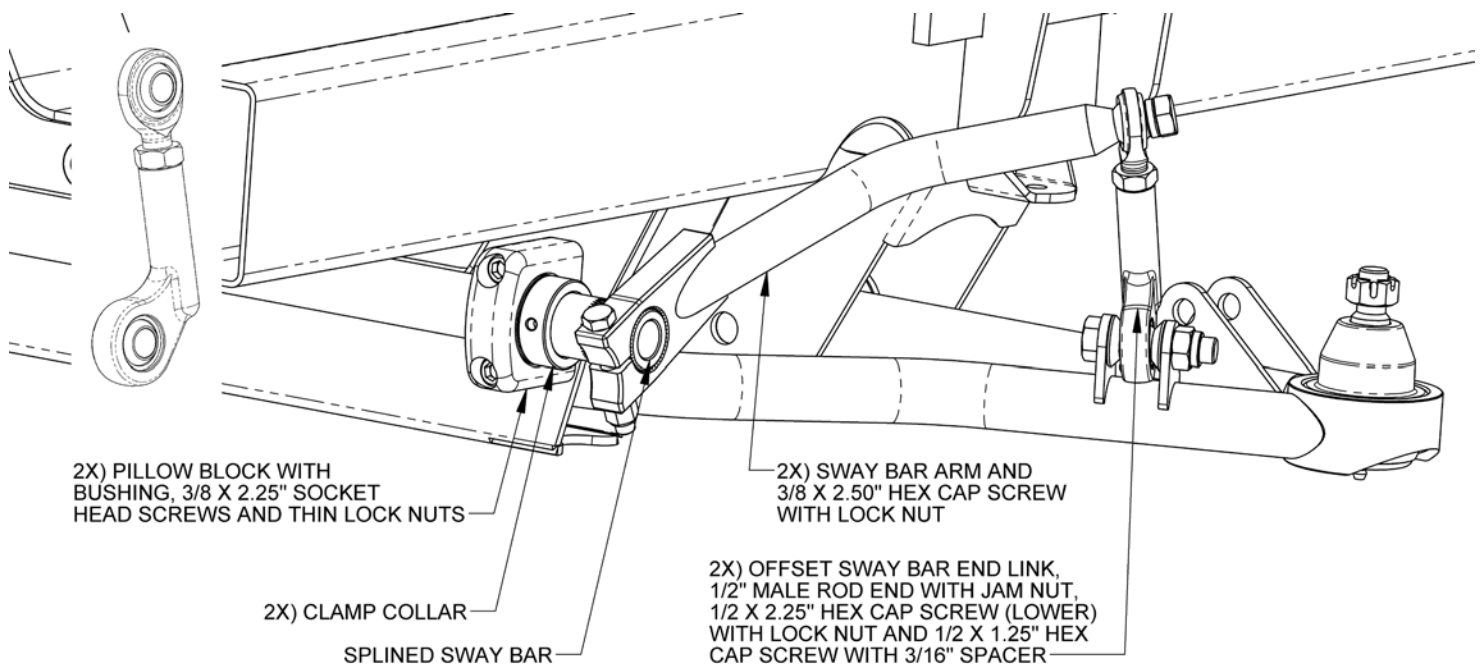

Install your brake kit (purchased separately) to the hub per the instructions included with your brake kit.

NOTE: For recommended part numbers please visit our website or contact one of our tech experts.

Mock up engine and transmission and install mounts as required. At this time, the front end can be reassembled. Some fabrication will be required to mount front fenders, body supports, radiator and front bumper brackets. All accessories and other components can now be installed.

INSTRUCTIONS

© 2025, Speedway Motors, Inc.

SPEEDWAY
motors®

Alignment:

The lower control arms should be level with all the weight on the car. To adjust the ride height, take the weight off the suspension and turn the threaded adjusters on the coil over shocks. Set down and measure ride height. Repeat as necessary to get the car where you want it. Once the ride height has been set, place the car back down on level ground. Adjust the free rod end on the sway bar end link so that it lines up with the bracket in the lower control arm. Keep adjusting the rod end until the remaining 1/2"-20 x 2-1/4" bolt will slide through easily. Secure it with the 1/2"-20 lock nut and tighten.

Set the alignment to the following initial settings:

Caster = 5°

Camber = Street: Negative .25° to .5° Race: Negative 1.5° to 3.0°

Toe = 0 to 1/8" Toe Out

Caster adjustments are made by changing the caster inserts. The caster inserts are identified with numbers indicating the distance of the hole from the center of the insert in 1/8" increments.

#1 = 1/8"

#2 = 1/4"

#3 = 3/8"

The inserts can be reversed to move the hole in front of or behind center for a total adjustment of 3/4" front to back.

Camber is adjusted using the included A-arm shim plates. Additional shim plates can be purchased separately if desired under Speedway Part # 917-21005. These are available in thicknesses ranging from 1/8" to 1/2".

INSTRUCTIONS

© 2025, Speedway Motors, Inc.



350-2000-56 - Universal G-Comp Subframe

Kit Contents	
P/N	Description
350-100.2	G-Comp Camber Shim Kit
350-1100	G-Comp X Spindle Upright
350-2000.1	56-58" Subframe Weldment
350-2000.3	Hardware Kit - 56"
350-203	G-Comp Upper Control Arms
350-204	G-Comp Lower Control Arms
350-207	G-Comp X Hub Bolt Kit
350-350	G-Comp X Front Hub
910-35010	G-Comp Steering Arm - Pair
910-35100	G-Comp 32" Standard Sway Bar
910-35250	G-Comp Sway Bar Arms
910-35345	Narrow P/S Rack For G-Comp
910-35900	G-Comp Sway Mount Kit

This kit is designed as a performance upgrade to the OEM suspension system in almost any vehicle. This installation will involve fabrication and welding to connect the new subframe weldment to the existing structure of the vehicle. As such, this should only be attempted by an experienced fabricator familiar with this type of work.

Please read and understand these instructions completely before starting this project.

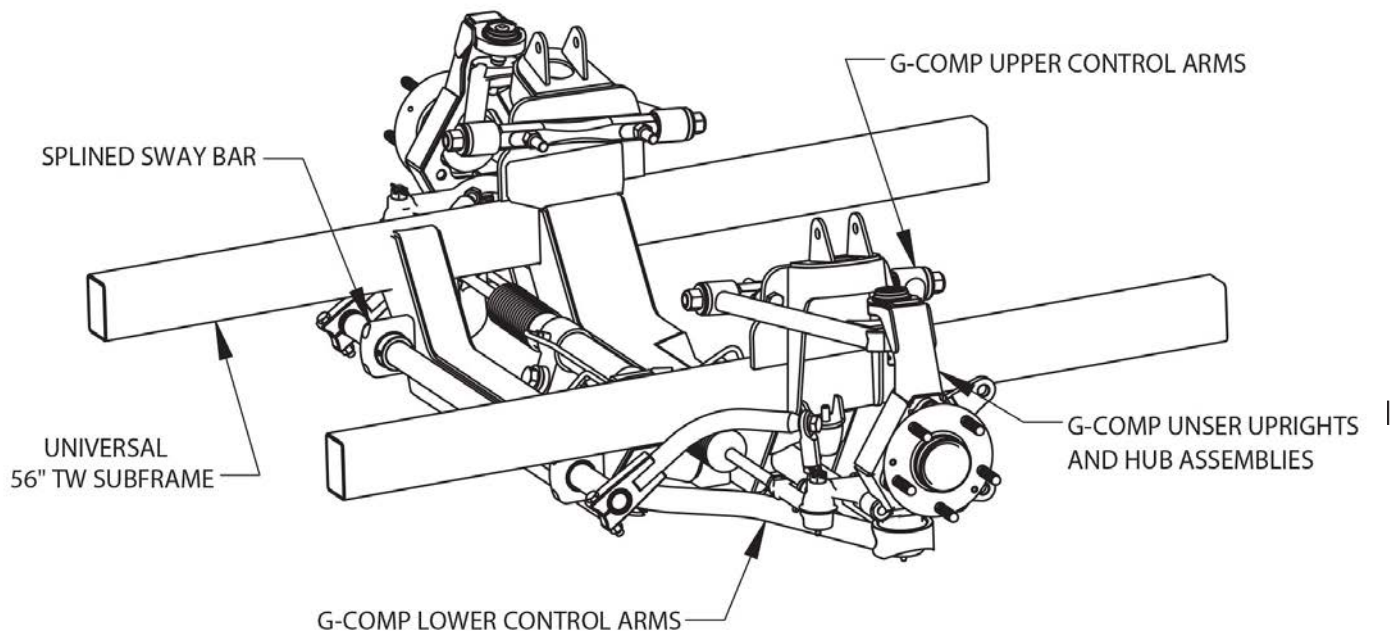

INSTRUCTIONS

© 2025, Speedway Motors, Inc.



To start, determine desired ride height based on the tire size you will be using. The axle centerline for this suspension is 1-1/2" above the lower surface of the frame rail at designed ride height and 26" back from the front edge of the subframe rail.

NOTE: This 26" dimension will vary slightly depending on how much caster you put in the suspension - more caster will move centerline back. Based on this, calculate the frame rail height dimension. For example: (see illustration below) if the proposed tire diameter is 28", then the centerline of the tire (spindle centerline) would be 14" (28" / 2) above ground level. Subtracting the 1-1/2" from the 14" leaves the lower surface of the rail at 12-1/2" above the ground. Now, substitute your desired tire diameter into this formula to calculate your frame rail height. Mock the vehicle up at your desired ride height and determine the best way to attach the subframe weldment to the existing structure of the vehicle while maintaining this relationship. In the case of a full frame car, cutting the existing frame near the firewall and fabricating a 2x3 (or similar) tube rail to attach the subframe to the existing structure is an option.

Depending on the condition of the existing frame or plans for the rear suspension, it may also be easier and better to fabricate an entirely new full frame. On unibody type vehicles, the job can be a bit tougher and require a bit more engineering. It is up to the fabricator to determine the best method to use and to ensure that the completed chassis is structurally rigid enough to handle the input loads that will occur as the vehicle is driven. If you are inexperienced in this type of fabrication, it is highly recommended that you seek the assistance of a professional shop that has experience in this area.

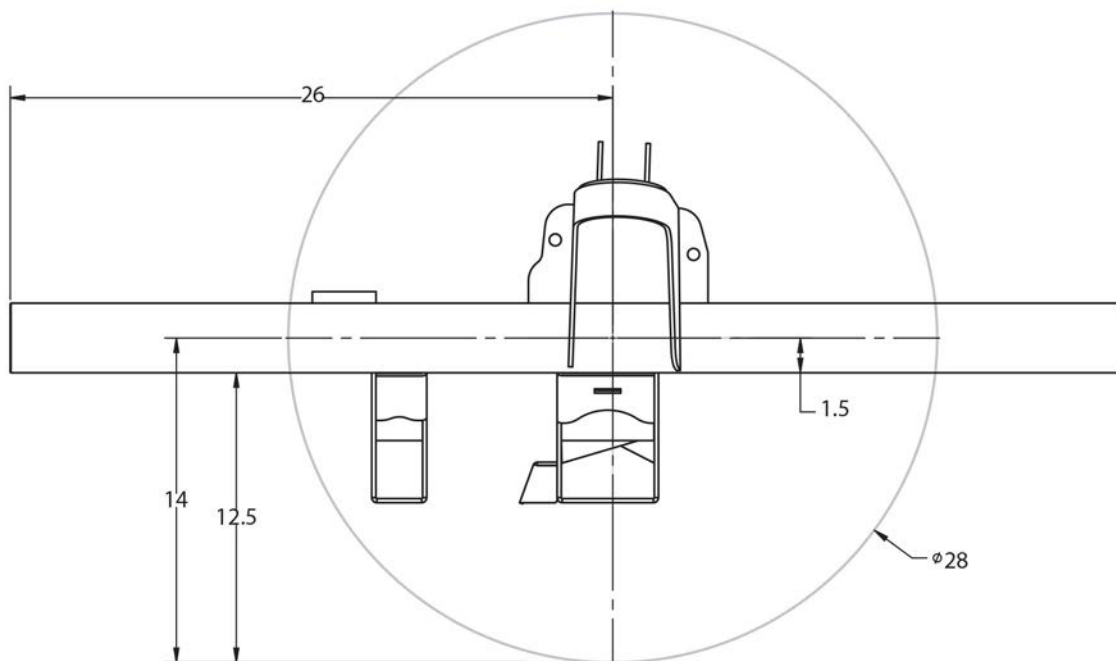

INSTRUCTIONS

© 2025, Speedway Motors, Inc.

1. Steering Rack. This G-comp front suspension kit is designed to use a narrowed thunderbird style rack. Install the steering rack as shown, using the two 9/16"-18 x 3 1/2" bolts, washers and lock nuts.

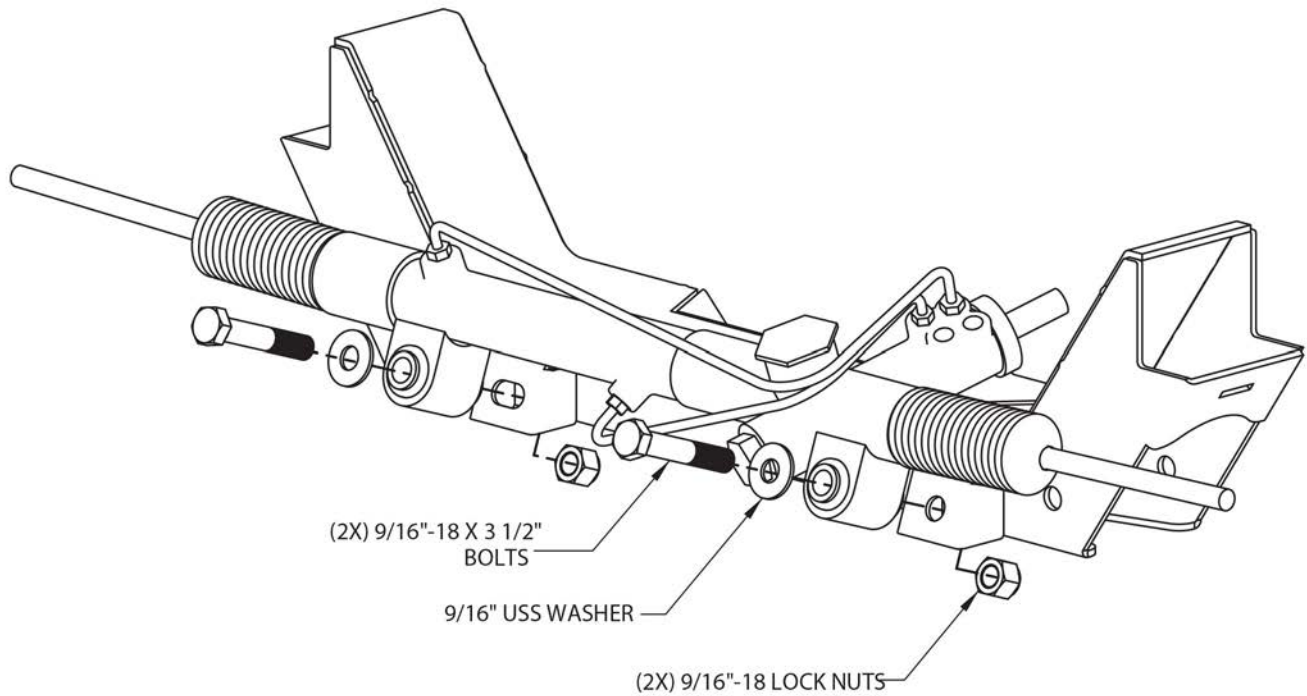

2. Install the lower control arms into the crossmember. Align the control arm bushings with the lower control arm holes in the crossmember. The front bolts, 5/8"-18 x 3-1/4" are to be installed from the front side. The rear bolts, 5/8"-18 x 5-1/2" are to be installed from the rear. Install the 5/8"-18 lock nuts and tighten. Install the lower control arm bump stops to the sub-frame using the supplied 3/8" lock nuts as shown.

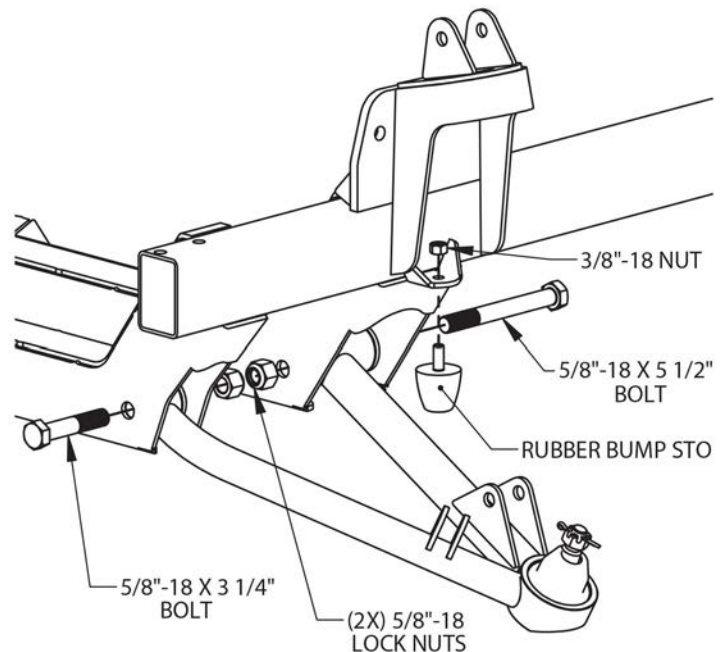

INSTRUCTIONS

© 2025, Speedway Motors, Inc.



3. Install the shocks. This procedure may vary slightly depending on the shocks used. Spin the adjusting collar onto the threaded shock body. Adjust the collar all the way to the bottom of the threads. Install the spring over the shock body.

NOTE: The G-Comp sub-frame has the upper spring retainer built into the sub-frame so the upper coil-over shock spring retainer is not used. Using the 1/2"-20 x 2-1/2" bolt and two 3/16" wide spacers, install the shock into the lower mount on the control arm. Secure it with a 1/2"-20 lock nut. Fully extend the shock and raise the lower arm so the upper shock mount and spring align with the shock mount and spring pocket on the sub-frame. Install the 1/2"-20 x 3" upper shock bolts and 7/16" wide spacers. Secure it with a 1/2"-20 lock nut.

NOTE: This kit is designed to use shocks with a compressed length of 10" and an extended length of 14". Shock ends should be 1/2" bearings with a mounting width of 1". For recommended part numbers, please visit our website or contact one of our tech experts.

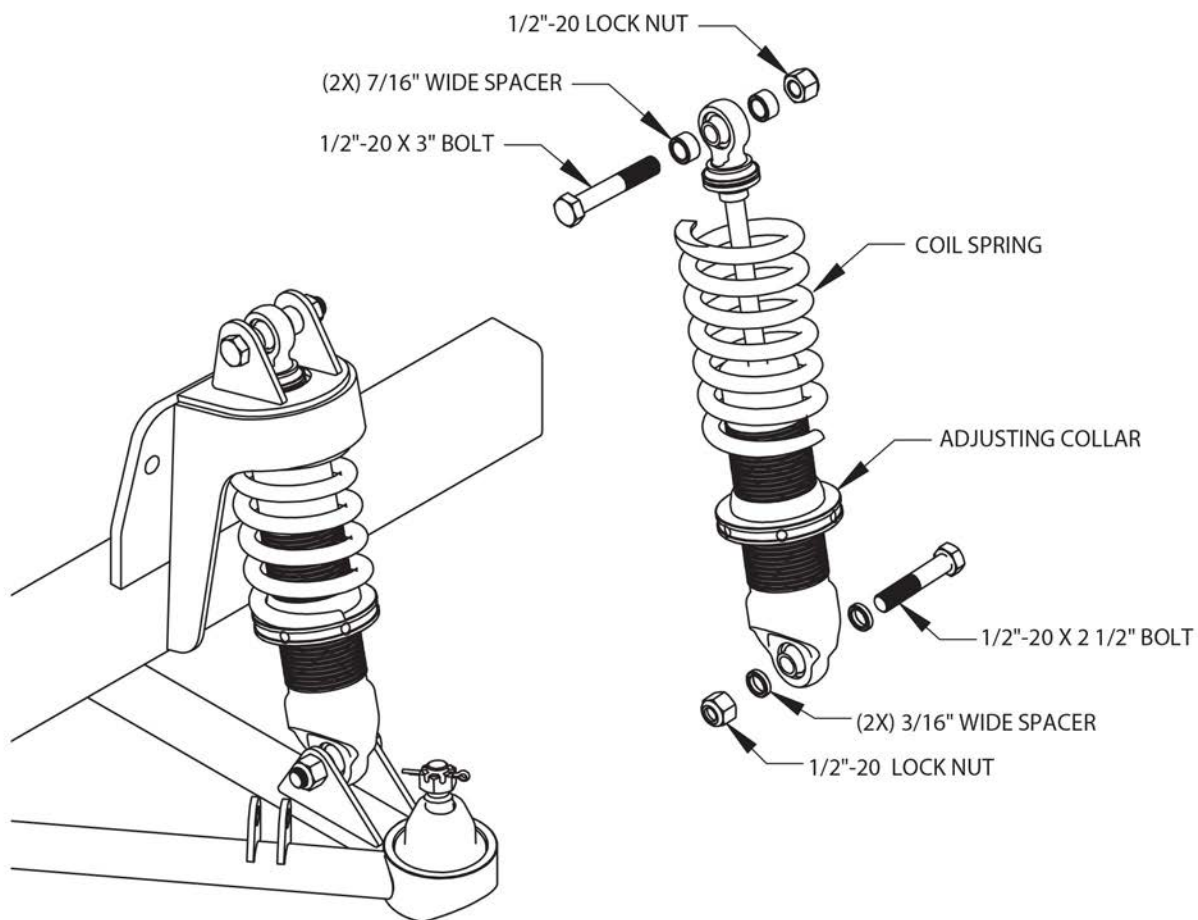

INSTRUCTIONS

© 2025, Speedway Motors, Inc.



4. Mount the upper control arms to the sub-frame using the 1/2"-20 x 2-3/4" bolts and lock nuts. The optional 3" long bolts (included) are to be used if needed for more negative camber. Rotate the cross shafts so the caster shim pockets are facing toward the center of the vehicle. Install the bolts through the caster shims, cross shafts, and the sub-frame as shown. Then secure with the 1/2"-20 locknuts. For initial installation, install the #2 caster shim with the hole positioned to the front of the pocket. This should give a good initial starting point for alignment.

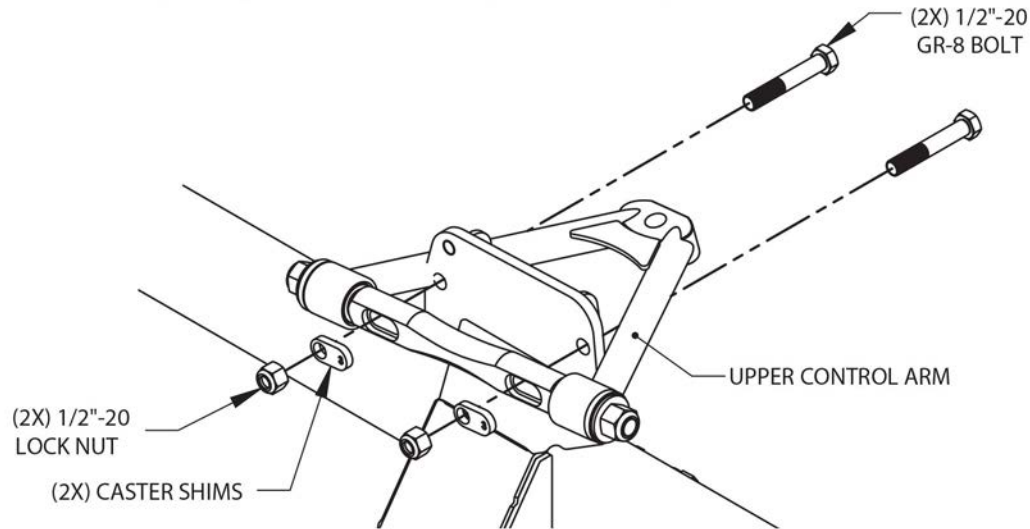

5. Install the uprights and steering arms. Install the upright onto the lower ball joint. Install and tighten the supplied castle nut. Repeat with the upper ball joint and install the cotter pins. Bolt the steering arms to the spindles using the 1/2"-20 x 1-3/4" bolts.

NOTE: Make sure to use Loctite on the threads.

6. Install the hubs. The Corvette style hubs included with this kit use metric hardware, including metric lug nuts. Using the supplied M12 metric bolts and Loctite, secure the hubs to the uprights. The fit of the hub into the upright is a close tolerance fit. It may be required to remove any paint or powder coating from the inner bore of the upright before assembly.

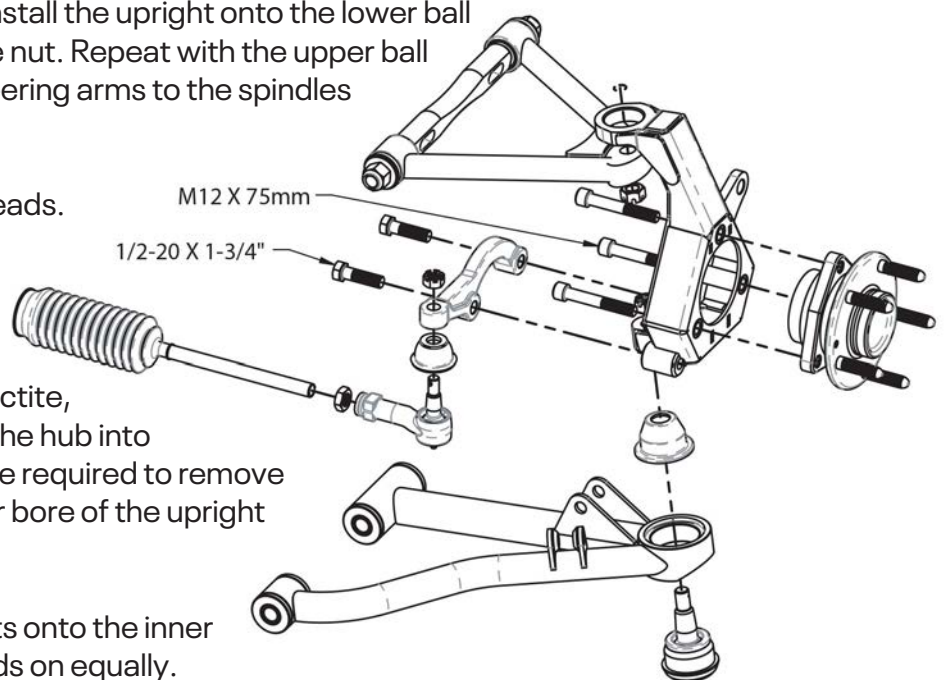

7. Install the outer tie rod ends and jam nuts onto the inner tie rods of the rack. Thread both tie rod ends on equally. Attach the tie rod ends to the steering arms using the castle nuts supplied with the tie rod ends. Tighten and install the cotter pins. Final alignment will be done at a later time.

INSTRUCTIONS

© 2025, Speedway Motors, Inc.

8. Sway bar assembly: Press the bushings into the aluminum pillow-blocks and install the pillow-blocks to the front cross member with the bushing shoulder to the inside. Use the four 3/8"-24 x 2-1/4" socket head cap screws and secure them with the 3/8"-24 thin lock nuts. Slide the sway bar through the bushings, installing the two clamp collars to the inside of both pillow blocks. Tighten the 3/8" cap screws.

Center the sway bar between the pillow blocks. Slide one clamp collar up against the bushing shoulder in the pillow block and tighten the set screw. Slide the second clamp collar up to the opposite bushing in the pillow block leaving about .075" of side clearance between the clamp collar and the bushing. Tighten the set screw. A nickel is about .075" thick and can be used as a spacer between the clamp collar and the bushing to provide the proper side clearance. Assemble the sway bar links as shown, leaving roughly 1/4" of threads showing. Slide the sway bar arms onto the splined ends of the sway bar aligning them flush with the end of the bar. Make sure they are parallel or "clocked" to one another then tighten the 3/8"-24 x 2-1/2" pinch bolts and lock nuts. Slide the 1/2"-20 x 1-1/4" bolts through the female heim joints and thread them into either end of the sway bar arms making sure to use Loctite on the threads.

Mount one of the lower links into the bracket on the lower control arm using a 1/2"-20 x 2-1/4" bolt and secure it with the 1/2"-20 lock nut. Leave the bolt out of the lower link on one side at this time. The second bolt/nut will be installed after the ride height is set and the car is setting on level ground. This will ensure that there is no preload on the sway bar at ride height.

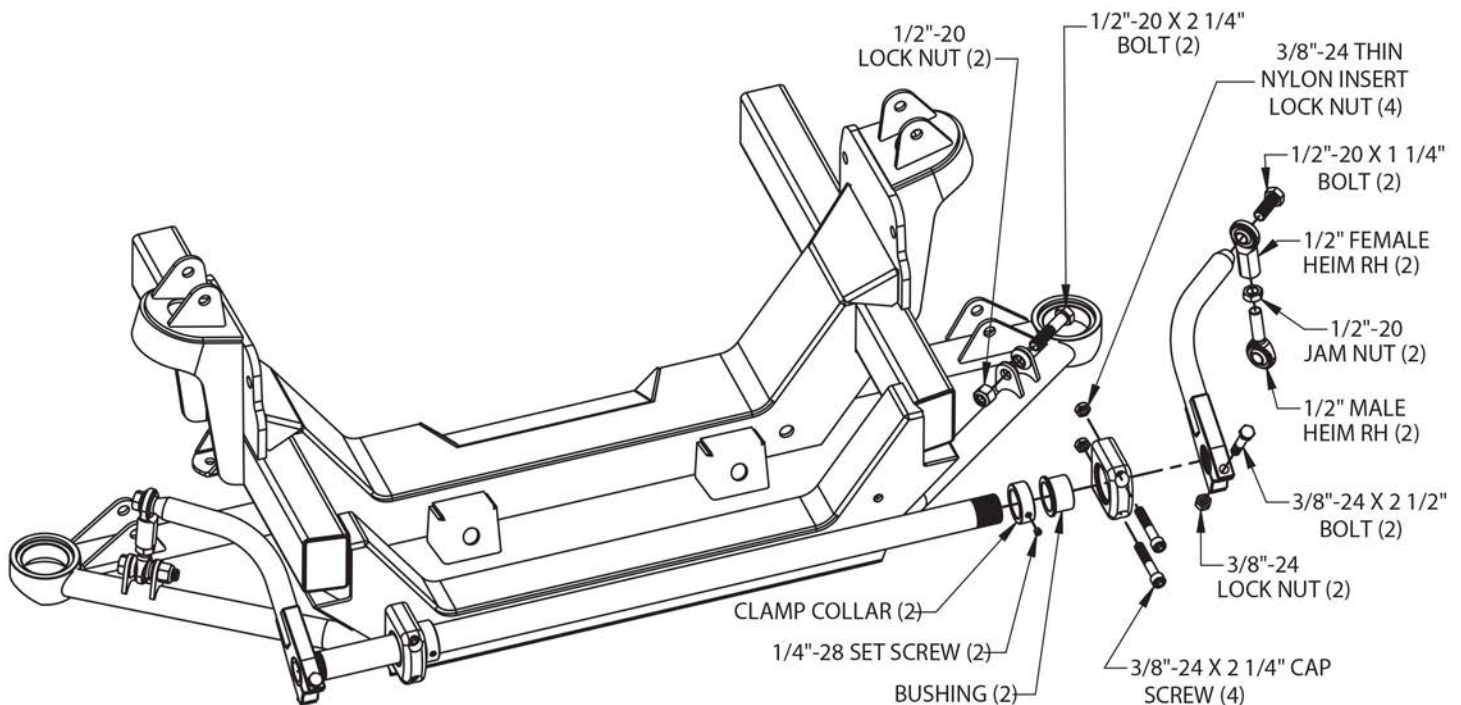

9. Install the brake kit to the hub per the instructions included with your brake kit.

NOTE: For recommended part numbers please visit our website or contact one of our tech experts.

INSTRUCTIONS

© 2025, Speedway Motors, Inc.



10. Mock up engine and transmission and install mounts as required. At this time, the front end can be reassembled. Some fabrication will be required to mount front fenders supports, radiator and front bumper brackets. All accessories and other components can now be installed.

11. Alignment. The lower control arms should be level with all the weight on the car. To adjust the ride height, take the weight off the suspension and turn the threaded adjusters on the coil over shocks. Once the ride height has been set, place the car back down on level ground. Adjust the free heim end on the sway bar link so that it lines up with the bracket in the lower control arm. Keep adjusting the heim end until the remaining 1/2"-20 x 2-1/4" bolt will slide through easily. Secure it with the 1/2"-20 lock nut and tighten.

Set the alignment to the following initial settings:

Caster = 5°

Camber = Street: Negative .25°-.5°

Race: Negative 1.5°-3.0°

Toe = 0" - 1/8" Toe Out

12. Caster adjustments are made by changing the caster inserts. The caster inserts are identified with numbers indicating the distance of the hole from the center of the insert in 1/8" increments.

#1 = 1/8"

#2 = 1/4"

#3 = 3/8"

The inserts can be reversed to move the hole in front of or behind center for a total adjustment of 3/4".

13. Camber is adjusted using the included A-arm shim plates. Additional shim plates can be purchased separately if desired under Speedway Part # 917-21005. These are available in thicknesses ranging from 1/8" to 1/2".

INSTRUCTIONS

© 2025, Speedway Motors, Inc.



350-2000-58 - Universal G-Comp Subframe

Kit Contents	
P/N	Description
350-100.2	G-Comp Camber Shim Kit
350-1100	G-Comp X Spindle Upright
350-2000.1	56-58" Subframe Weldment
350-2000.4	Hardware Kit - 58"
350-903	G-Comp Upper Control Arms +1"
350-904	G-Comp Lower Control Arms +1"
350-207	G-Comp X Hub Bolt Kit
350-350	G-Comp X Front Hub
910-35010	G-Comp Steering Arm - Pair
910-35100	G-Comp 32" Standard Sway Bar
910-35250	G-Comp Sway Bar Arms
910-35345	Narrow P/S Rack For G-Comp
910-35900	G-Comp Sway Bar Mount Kit

This kit is designed as a performance upgrade to the OEM suspension system in almost any vehicle. This installation will involve fabrication and welding to connect the new subframe weldment to the existing structure of the vehicle. As such, this should only be attempted by an experienced fabricator familiar with this type of work.

Please read and understand these instructions completely before starting this project.

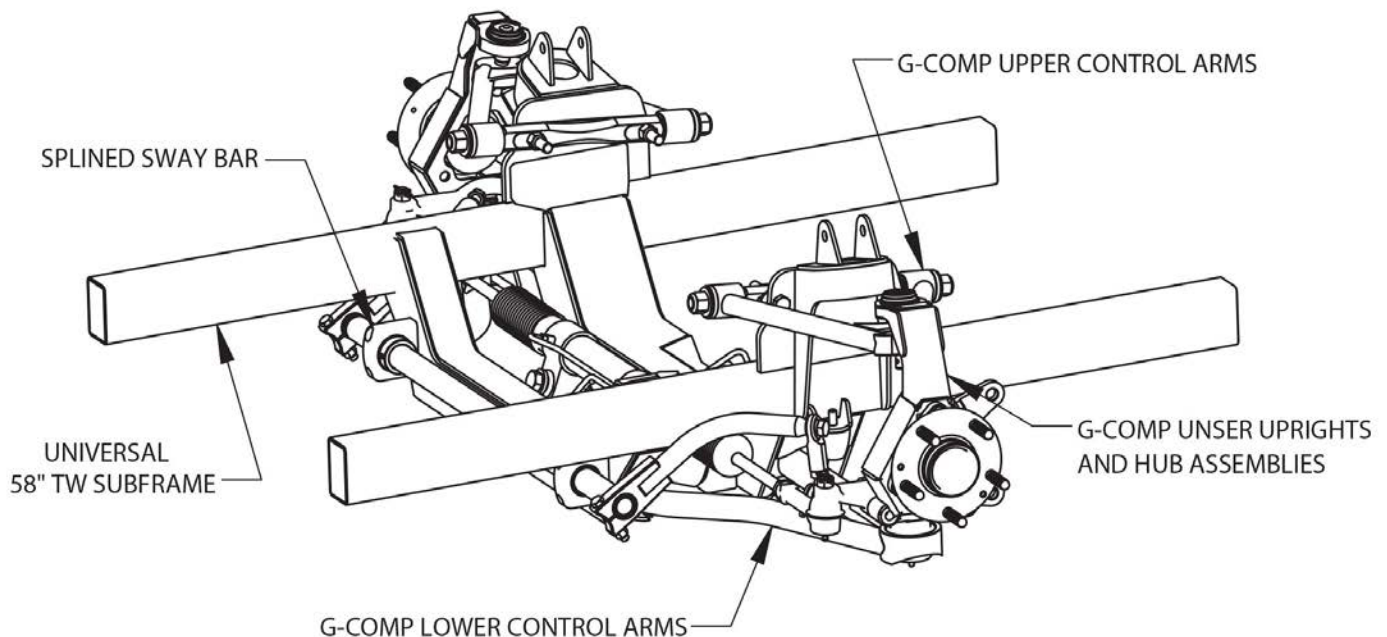

INSTRUCTIONS

© 2025, Speedway Motors, Inc.



To start, determine desired ride height based on the tire size you will be using. The axle centerline for this suspension is 1-1/2" above the lower surface of the frame rail at designed ride height and 26" back from the front edge of the subframe rail.

NOTE: This 26" dimension will vary slightly depending on how much caster you put in the suspension - more caster will move centerline back. Based on this, calculate the frame rail height dimension. For example: (see illustration below) if the proposed tire diameter is 28", then the centerline of the tire (spindle centerline) would be 14" (28" / 2) above ground level. Subtracting the 1-1/2" from the 14" leaves the lower surface of the rail at 12-1/2" above the ground. Now, substitute your desired tire diameter into this formula to calculate your frame rail height. Mock the vehicle up at your desired ride height and determine the best way to attach the subframe weldment to the existing structure of the vehicle while maintaining this relationship. In the case of a full frame car, cutting the existing frame near the firewall and fabricating a 2x3 (or similar) tube rail to attach the subframe to the existing structure is an option.

Depending on the condition of the existing frame or plans for the rear suspension, it may also be easier and better to fabricate an entirely new full frame. On unibody type vehicles, the job can be a bit tougher and require a bit more engineering. It is up to the fabricator to determine the best method to use and to ensure that the completed chassis is structurally rigid enough to handle the input loads that will occur as the vehicle is driven. If you are inexperienced in this type of fabrication, it is highly recommended that you seek the assistance of a professional shop that has experience in this area.

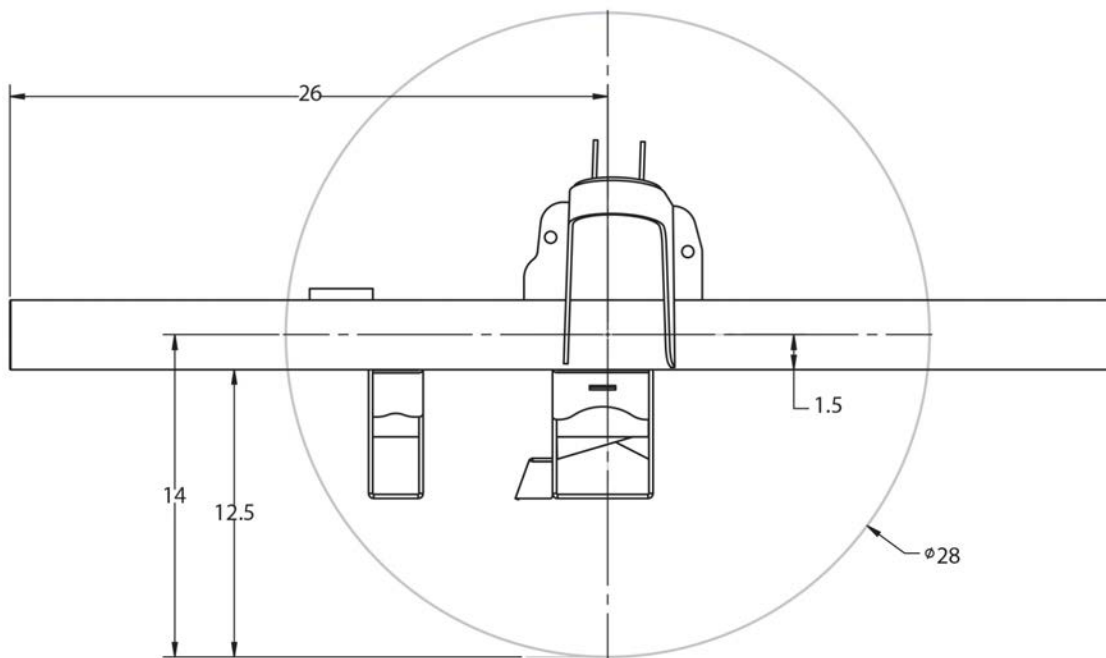

INSTRUCTIONS

© 2025, Speedway Motors, Inc.



1. Steering Rack. This G-comp front suspension kit is designed to use a narrowed thunderbird style rack. Install the steering rack as shown, using the two 9/16"-18 x 3 1/2" bolts, washers and lock nuts.

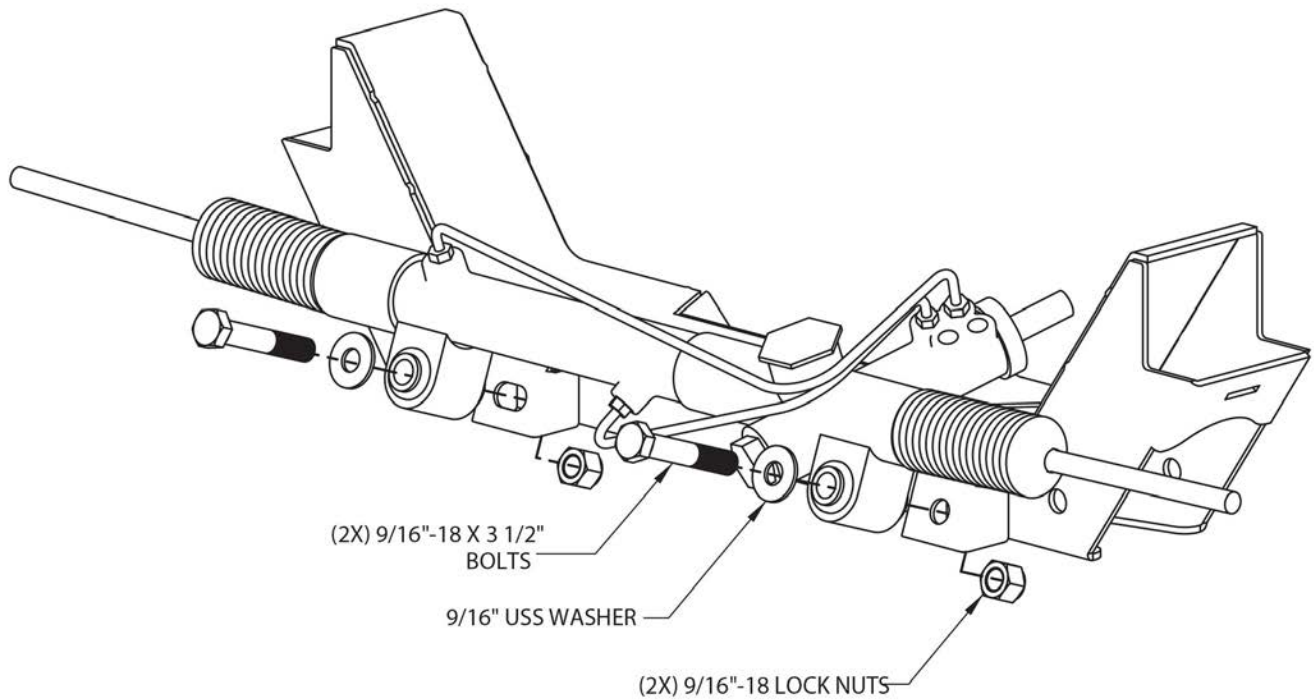

2. Install the lower control arms into the crossmember. Align the control arm bushings with the lower control arm holes in the crossmember. The front bolts, 5/8"-18 x 3-1/4" are to be installed from the front side. The rear bolts, 5/8"-18 x 5-1/2" are to be installed from the rear. Install the 5/8"-18 lock nuts and tighten. Install the lower control arm bump stops to the sub-frame using the supplied 3/8" lock nuts as shown.

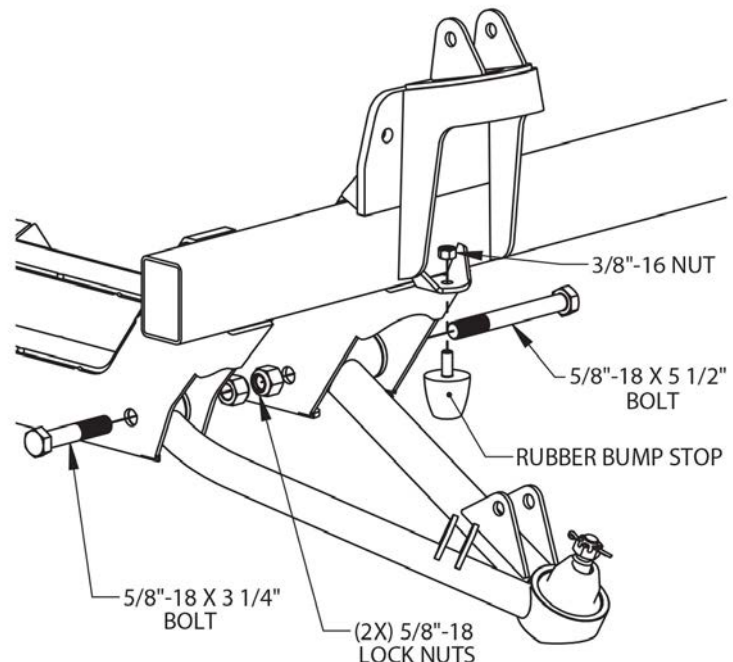

INSTRUCTIONS

© 2025, Speedway Motors, Inc.



3. Install the shocks. This procedure may vary slightly depending on the shocks used. Spin the adjusting collar onto the threaded shock body. Adjust the collar all the way to the bottom of the threads. Install the spring over the shock body.

NOTE: The G-Comp sub-frame has the upper spring retainer built into the sub-frame so the upper coil-over shock spring retainer is not used. Using the 1/2"-20 x 2-1/2" bolt and two 3/16" wide spacers, install the shock into the lower mount on the control arm. Secure it with a 1/2"-20 lock nut. Fully extend the shock and raise the lower arm so the upper shock mount and spring align with the shock mount and spring pocket on the sub-frame. Install the 1/2"-20 x 3" upper shock bolts and 7/16" wide spacers. Secure it with a 1/2"-20 lock nut.

NOTE: This kit is designed to use shocks with a compressed length of 10" and an extended length of 14". Shock ends should be 1/2" bearings with a mounting width of 1". For recommended part numbers, please visit our website or contact one of our tech experts.

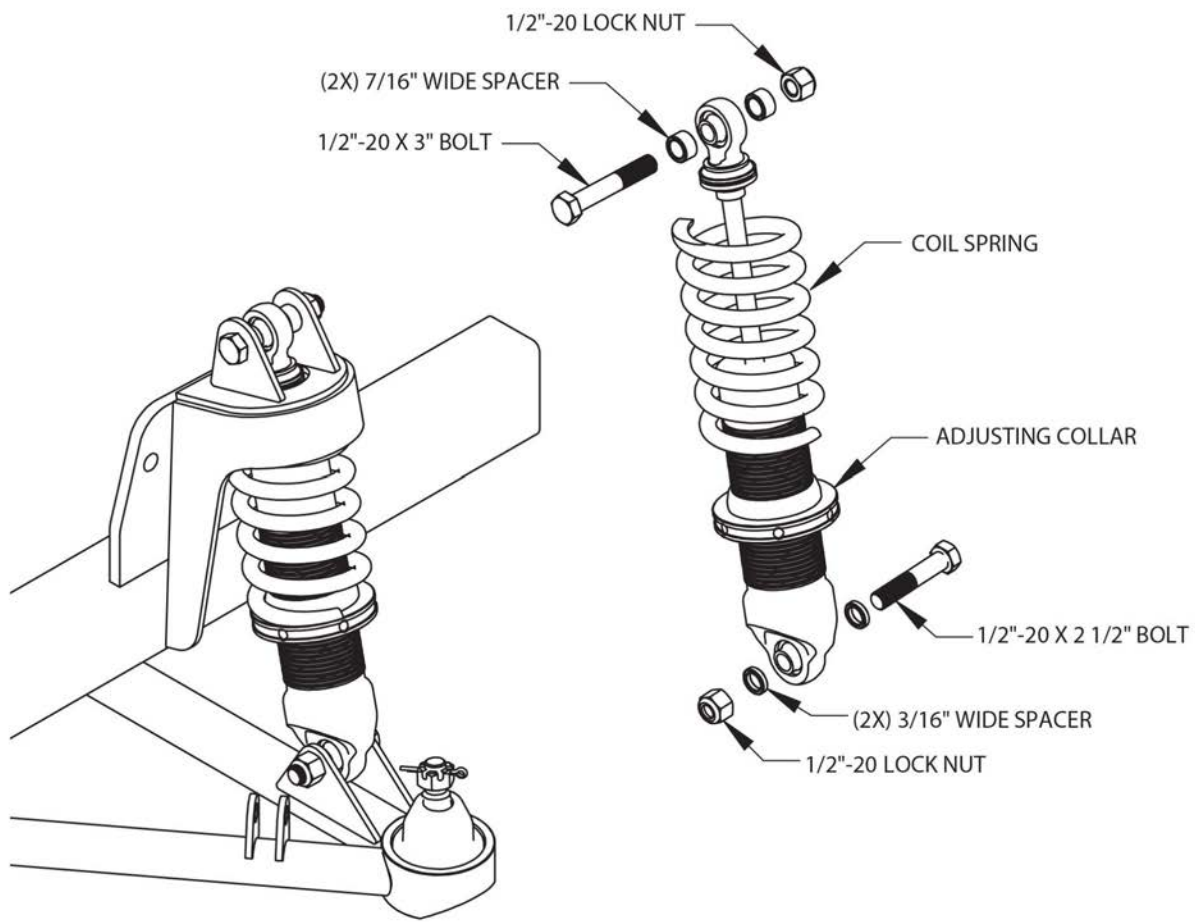

INSTRUCTIONS

© 2025, Speedway Motors, Inc.



4. Mount the upper control arms to the sub-frame using the 1/2"-20 x 2-3/4" bolts and lock nuts. The optional 3" long bolts (included) are to be used if needed for more negative camber. Rotate the cross shafts so the caster shim pockets are facing toward the center of the vehicle. Install the bolts through the caster shims, cross shafts, and the sub-frame as shown. Then secure with the 1/2"-20 locknuts. For initial installation, install the #2 caster shim with the hole positioned to the front of the pocket. This should give a good initial starting point for alignment.

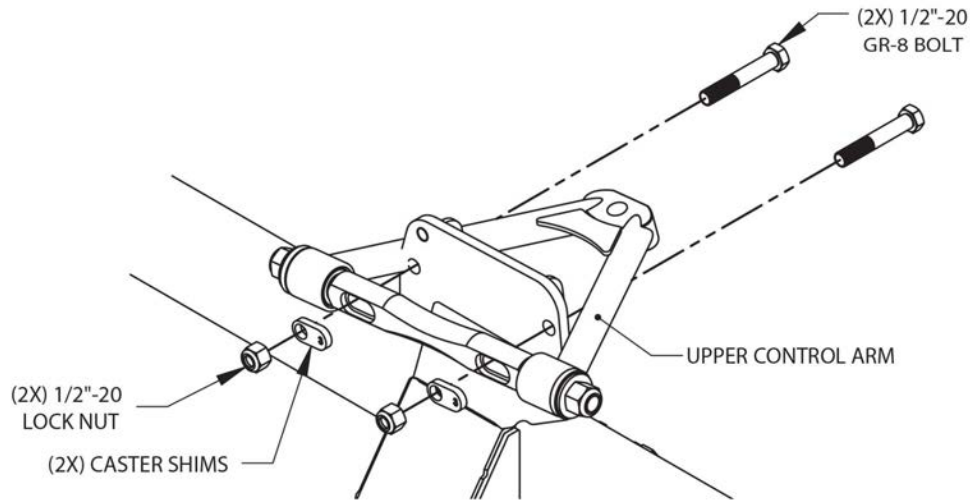

5. Install the uprights and steering arms. Install the upright onto the lower ball joint. Install and tighten the supplied castle nut. Repeat with the upper ball joint and install the cotter pins. Bolt the steering arms to the spindles using the 1/2"-20 x 1-3/4" bolts.

NOTE: Make sure to use Loctite on the threads.

6. Install the hubs. The Corvette style hubs included with this kit use metric hardware, including metric lug nuts. Using the supplied M12 metric bolts and Loctite, secure the hubs to the uprights. The fit of the hub into the upright is a close tolerance fit. It may be required to remove any paint or powder coating from the inner bore of the upright before assembly.

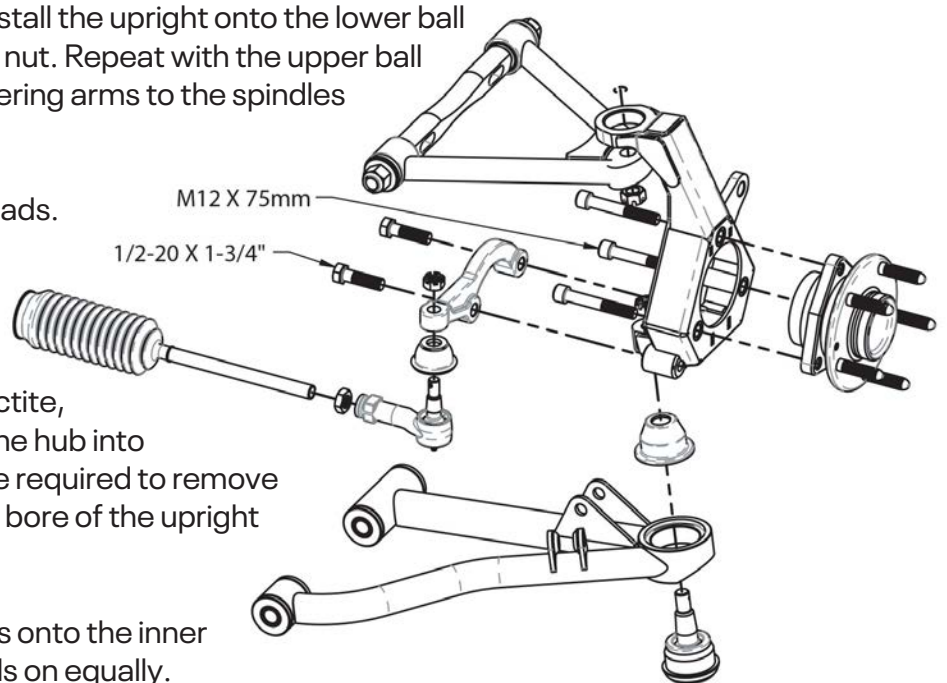

7. Install the outer tie rod ends and jam nuts onto the inner tie rods of the rack. Thread both tie rod ends on equally. Attach the tie rod ends to the steering arms using the castle nuts supplied with the tie rod ends. Tighten and install the cotter pins. Final alignment will be done at a later time.

INSTRUCTIONS

© 2025, Speedway Motors, Inc.

8. Sway bar assembly: Press the bushings into the aluminum pillow-blocks and install the pillow-blocks to the front cross member with the bushing shoulder to the inside. Use the four 3/8"-24 x 2-1/4" socket head cap screws and secure them with the 3/8"-24 thin lock nuts. Slide the sway bar through the bushings, installing the two clamp collars to the inside of both pillow blocks. Tighten the 3/8" cap screws.

Center the sway bar between the pillow blocks. Slide one clamp collar up against the bushing shoulder in the pillow block and tighten the set screw. Slide the second clamp collar up to the opposite bushing in the pillow block leaving about .075" of side clearance between the clamp collar and the bushing. Tighten the set screw. A nickel is about .075" thick and can be used as a spacer between the clamp collar and the bushing to provide the proper side clearance. Assemble the sway bar links as shown, leaving roughly 1/4" of threads showing. Slide the sway bar arms onto the splined ends of the sway bar aligning them flush with the end of the bar. Make sure they are parallel or "clocked" to one another then tighten the 3/8"-24 x 2-1/2" pinch bolts and lock nuts. Slide the 1/2"-20 x 1-1/4" bolts through the female heim joints and thread them into either end of the sway bar arms making sure to use Loctite on the threads.

Mount one of the lower links into the bracket on the lower control arm using a 1/2"-20 x 2-1/4" bolt and secure it with the 1/2"-20 lock nut. Leave the bolt out of the lower link on one side at this time. The second bolt/nut will be installed after the ride height is set and the car is setting on level ground. This will ensure that there is no preload on the sway bar at ride height.

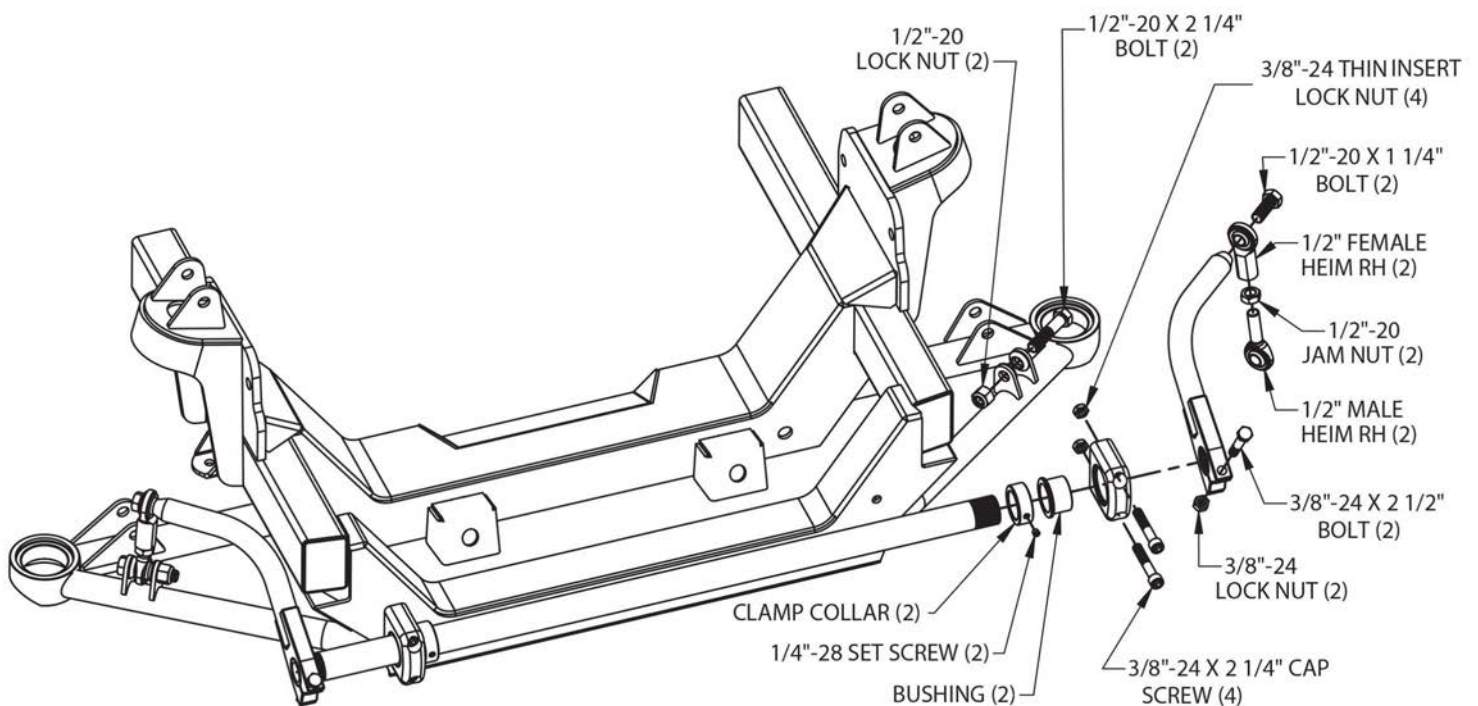

9. Install the brake kit to the hub per the instructions included with your brake kit.

NOTE: For recommended part numbers please visit our website or contact one of our tech experts.

INSTRUCTIONS



© 2025, Speedway Motors, Inc.

10. Mock up engine and transmission and install mounts as required. At this time, the front end can be reassembled. Some fabrication will be required to mount front fenders supports, radiator and front bumper brackets. All accessories and other components can now be installed.

11. Alignment. The lower control arms should be level with all the weight on the car. To adjust the ride height, take the weight off the suspension and turn the threaded adjusters on the coil over shocks. Once the ride height has been set, place the car back down on level ground. Adjust the free heim end on the sway bar link so that it lines up with the bracket in the lower control arm. Keep adjusting the heim end until the remaining 1/2"-20 x 2-1/4" bolt will slide through easily. Secure it with the 1/2"-20 lock nut and tighten.

Set the alignment to the following initial settings:

Caster = 5°

Camber = Street: Negative .25°-.5°

Race: Negative 1.5°-3.0°

Toe = 0" - 1/8" Toe Out

12. Caster adjustments are made by changing the caster inserts. The caster inserts are identified with numbers indicating the distance of the hole from the center of the insert in 1/8" increments.

#1 = 1/8"

#2 = 1/4"

#3 = 3/8"

The inserts can be reversed to move the hole in front of or behind center for a total adjustment of 3/4".

13. Camber is adjusted using the included A-arm shim plates. Additional shim plates can be purchased separately if desired under Speedway Part # 917-21005. These are available in thicknesses ranging from 1/8" to 1/2".

INSTRUCTIONS

© 2025, Speedway Motors, Inc.



350-2000-60 - Universal G-Comp Subframe

Kit Contents	
P/N	Description
350-100.2	G-Comp Camber Shim Kit
350-1100	G-Comp X Spindle Upright
350-2000.2	60-62" Subframe Weldment
350-2000.5	Hardware Kit - 60"
350-203	G-Comp Upper Control Arms
350-204	G-Comp Lower Control Arms
350-207	G-Comp X Hub Bolt Kit
350-350	G-Comp X Front Hub
910-35011	G-Comp Steering Arm - Pair
350-501	G-Comp 34" Standard Sway Bar
350-500.2	Sway Bar Kit
910-35341	New T-Bird Power Rack

This kit is designed as a performance upgrade to the OEM suspension system in almost any vehicle. This installation will involve fabrication and welding to connect the new subframe weldment to the existing structure of the vehicle. As such, this should only be attempted by an experienced fabricator familiar with this type of work.

Please read and understand these instructions completely before starting this project.

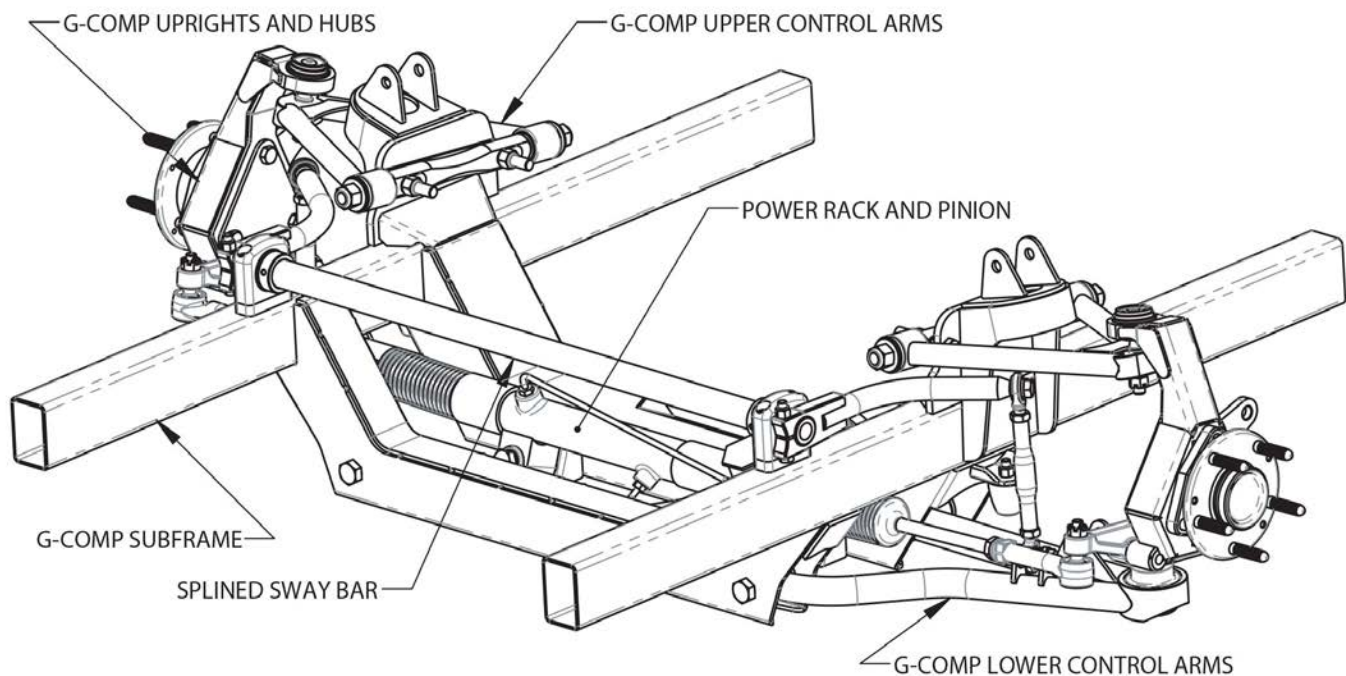

INSTRUCTIONS

© 2025, Speedway Motors, Inc.



To start, determine desired ride height based on the tire size you will be using. The axle centerline for this suspension is $3/4$ " above the lower surface of the frame rail at designed ride height and 26" back from the front edge of the subframe rail.

NOTE: This 26" dimension will vary slightly depending on how much caster you put in the suspension - more caster will move centerline back. Based on this, calculate the frame rail height dimension. For example: (see illustration below) if the proposed tire diameter is 28", then the centerline of the tire (spindle centerline) would be 14" ($28"/2$) above ground level. Subtracting the $3/4$ " from the 14" leaves the lower surface of the rail at 13- $1/4$ " above the ground. Now, substitute your desired tire diameter into this formula to calculate your frame rail height. Mock the vehicle up at your desired ride height and determine the best way to attach the subframe weldment to the existing structure of the vehicle while maintaining this relationship. In the case of a full frame car, cutting the existing frame near the firewall and fabricating a 2x3 (or similar) tube rail to attach the subframe to the existing structure is an option.

Depending on the condition of the existing frame or plans for the rear suspension, it may also be easier and better to fabricate an entirely new full frame. On unibody type vehicles, the job can be a bit tougher and require a bit more engineering. It is up to the fabricator to determine the best method to use and to ensure that the completed chassis is structurally rigid enough to handle the input loads that will occur as the vehicle is driven. If you are inexperienced in this type of fabrication, it is highly recommended that you seek the assistance of a professional shop that has experience in this area.

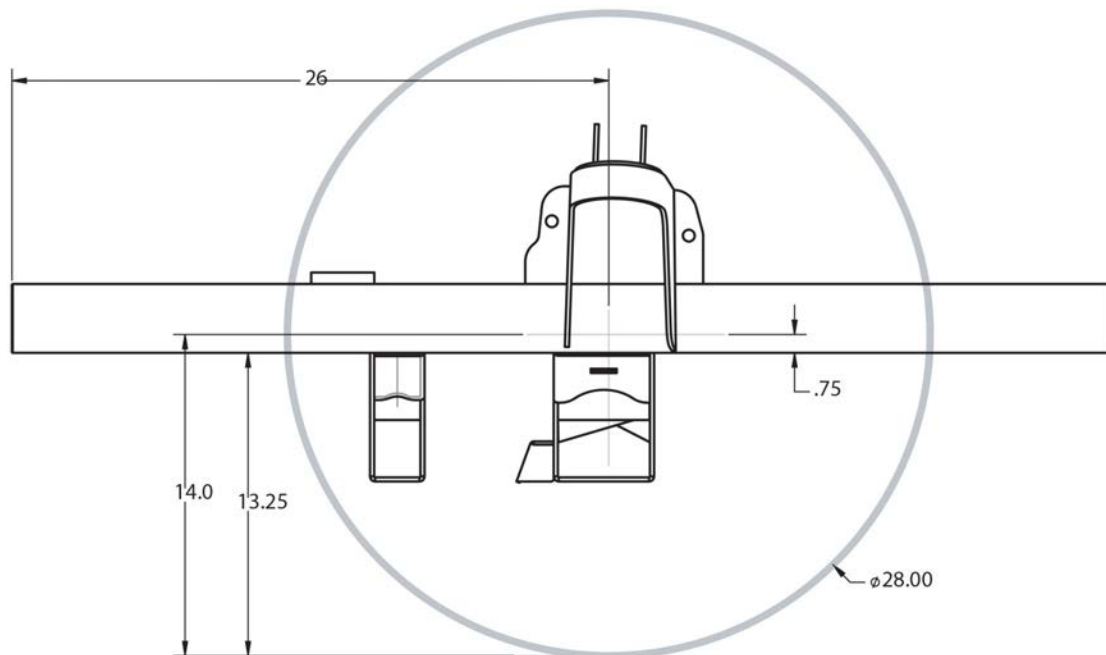

INSTRUCTIONS

SPEEDWAY
motors®

© 2025, Speedway Motors, Inc.

1. Steering Rack. This G-comp front suspension kit is designed to use a Thunderbird style power steering rack. Install the steering rack as shown, using the two 5/8"-18 x 3 1/2" bolts, washers and lock nuts.

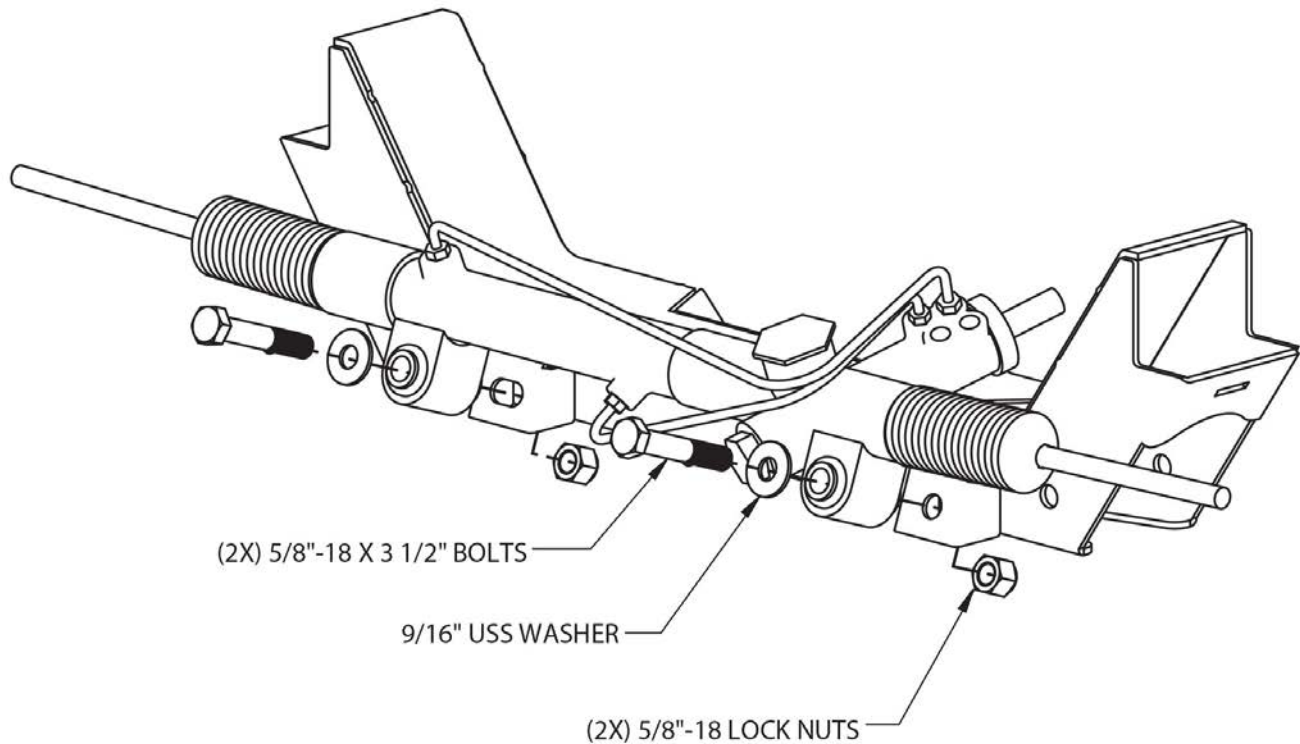

2. Install the lower control arms into the crossmember. Align the control arm bushings with the lower control arm holes in the crossmember. The front bolts, 5/8"-18 x 3-1/4" are to be installed from the front side. The rear bolts, 5/8"-18 x 5-1/2" are to be installed from the rear. Install the 5/8"-18 lock nuts and tighten. Install the lower control arm bump stops to the sub-frame using the supplied 3/8" lock nuts as shown.

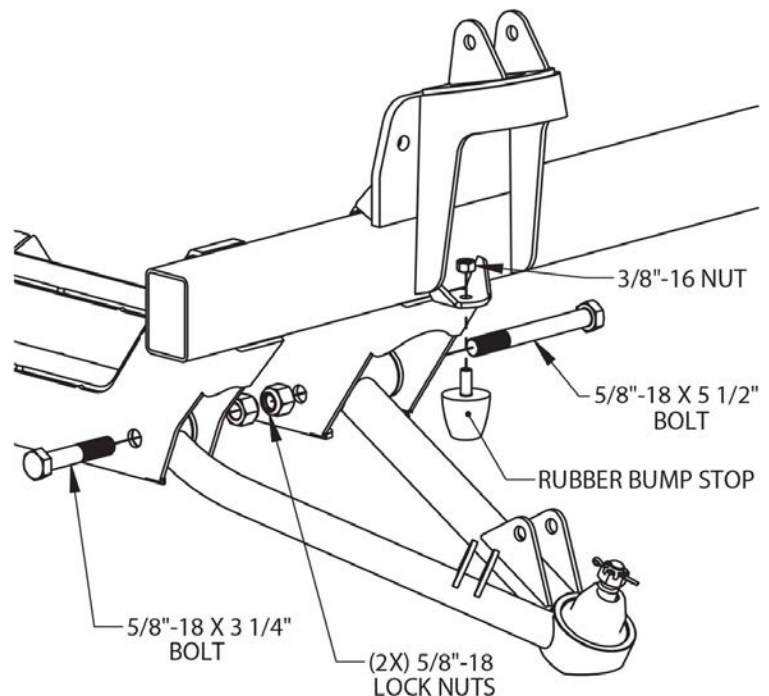

INSTRUCTIONS

© 2025, Speedway Motors, Inc.



3. Install the shocks. This procedure may vary slightly depending on the shocks used. Spin the adjusting collar onto the threaded shock body. Adjust the collar all the way to the bottom of the threads. Install the spring over the shock body.

NOTE: The G-Comp sub-frame has the upper spring retainer built into the sub-frame so the upper coil-over shock spring retainer is not used. Using the 1/2"-20 x 2-1/2" bolt and two 3/16" wide spacers, install the shock into the lower mount on the control arm. Secure it with a 1/2"-20 lock nut. Fully extend the shock and raise the lower arm so the upper shock mount and spring align with the shock mount and spring pocket on the sub-frame. Install the 1/2"-20 x 3" upper shock bolts and 7/16" wide spacers. Secure it with a 1/2"-20 lock nut.

NOTE: This kit is designed to use shocks with a compressed length of 10" and an extended length of 14". Shock ends should be 1/2" bearings with a mounting width of 1". For recommended part numbers, please visit our website or contact one of our tech experts.

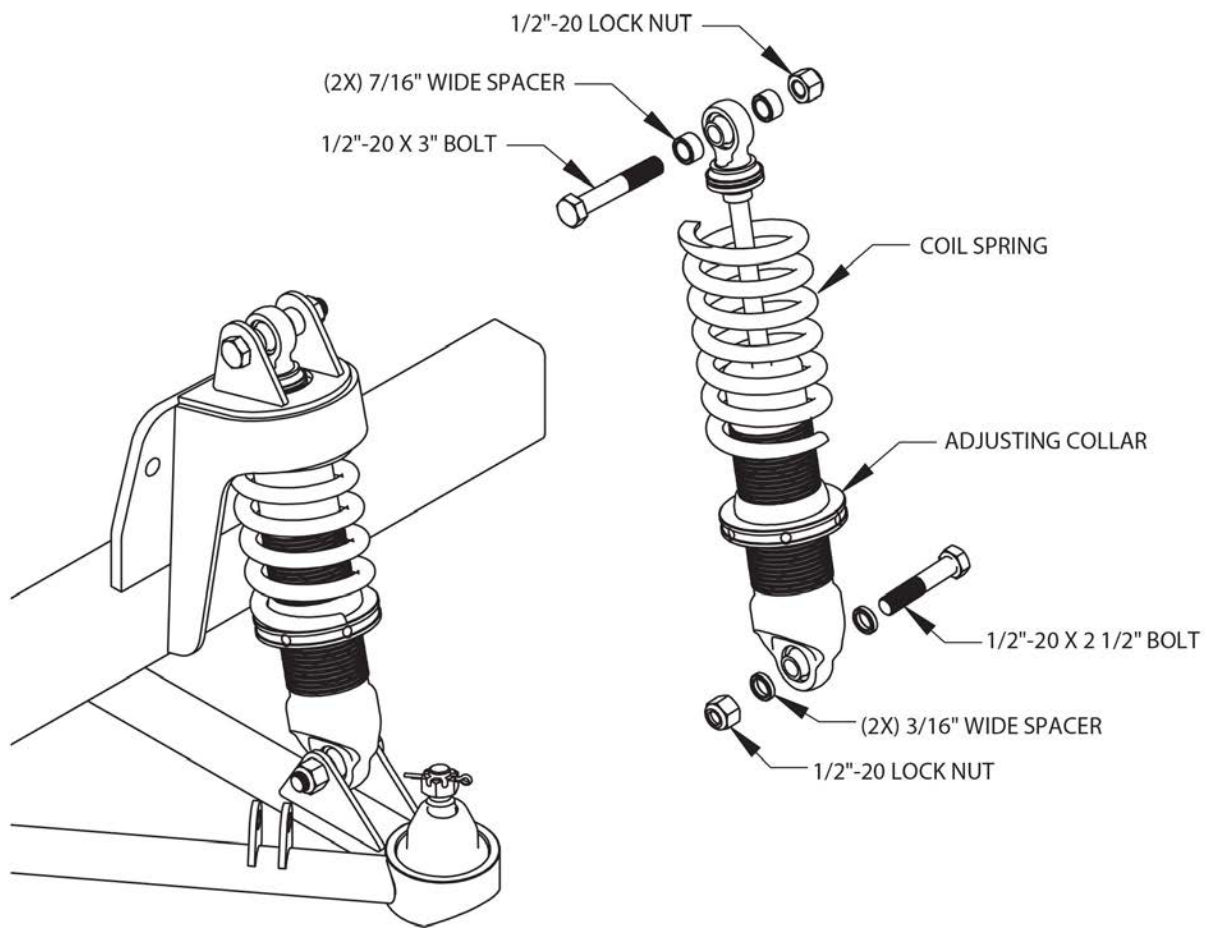

INSTRUCTIONS

© 2025, Speedway Motors, Inc.

SPEEDWAY
motors®

4. Mount the upper control arms to the sub-frame using the 1/2"-20 x 2-3/4" bolts and lock nuts. The optional 3" bolts (included) are to be used if needed to achieve more negative camber. Rotate the cross shafts so the caster shim pockets are facing toward the center of the vehicle. Install the bolts through the caster shims, cross shafts, and the sub-frame as shown. Then secure with the 1/2"-20 locknuts. For initial installation, install the #2 caster shim with the hole positioned to the front of the pocket. This should give a good initial starting point for alignment.

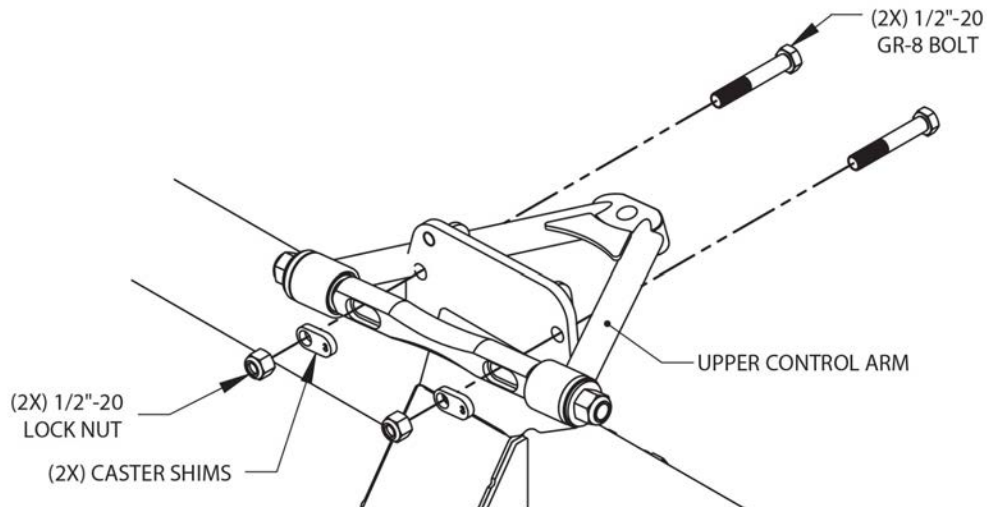

5. Install the uprights and steering arms. Install the upright onto the lower ball joint. Install and tighten the supplied castle nut. Repeat with the upper ball joint and install the cotter pins. Bolt the steering arms to the spindles using the 1/2"-20 x 1-3/4" bolts.

NOTE: Make sure to use Loctite on the threads.

6. Install the hubs. The Corvette style hubs included with this kit use metric hardware, including metric lug nuts. Using the supplied M12 metric bolts and Loctite, secure the hubs to the uprights. The fit of the hub into the upright is a close tolerance fit. It may be required to remove any paint or powder coating from the inner bore of the upright before assembly.

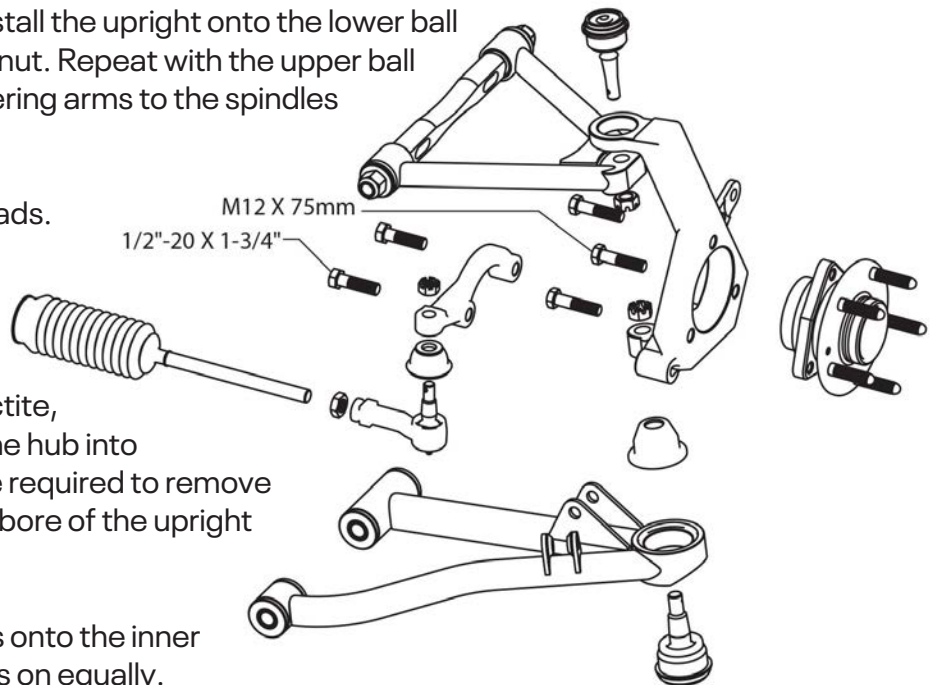

7. Install the outer tie rod ends and jam nuts onto the inner tie rods of the rack. Thread both tie rod ends on equally. Attach the tie rod ends to the steering arms using the castle nuts supplied with the tie rod ends. Tighten and install the cotter pins. Final alignment will be done at a later time.

INSTRUCTIONS

© 2025, Speedway Motors, Inc.



8. Sway bar assembly: Press the bushings into the aluminum pillow blocks and install the pillow blocks to the front crossmember with the bushing shoulder to the inside. Use the four 3/8"-16 x 2-1/4" socket head cap screws to secure the pillow block to the subframe. Before fully tightening the bolts, slide the sway bar through the bushings, installing the two clamp collars to the inside of both pillow blocks. Now, tighten the 3/8" socket cap screws. Center the sway bar between the pillow blocks. Slide one clamp collar up against the bushing shoulder in the pillow block and tighten the set screw. Slide the second clamp collar up to the opposite bushing in the pillow block leaving about .075" of side clearance between the clamp collar and the bushing. Tighten the set screw.

NOTE: A nickel is about .075" thick and can be used as a spacer between the clamp collar and the bushing to provide the proper side clearance. Slide the sway bar arms onto the splined ends of the sway bar aligning them flush with the end of the bar. Make sure they are parallel or "clocked" to one another then tighten the 3/8"-24 x 2-1/2" pinch bolts and lock nuts. Assemble the sway bar links as shown, leaving roughly 1/4" of threads showing on either heim joint. Use the 1/2"-20 x 1-1/4" bolts to secure the sway bar link to the sway bar arm.

Mount one of the lower links into the bracket on the lower control arm using a 1/2"-20 x 2-1/4" bolt and secure it with the 1/2"-20 lock nut. Leave the bolt out of the lower link on one side at this time. The second bolt/nut will be installed after the ride height is set and the car is setting on level ground. This will ensure that there is no preload on the sway bar at ride height.

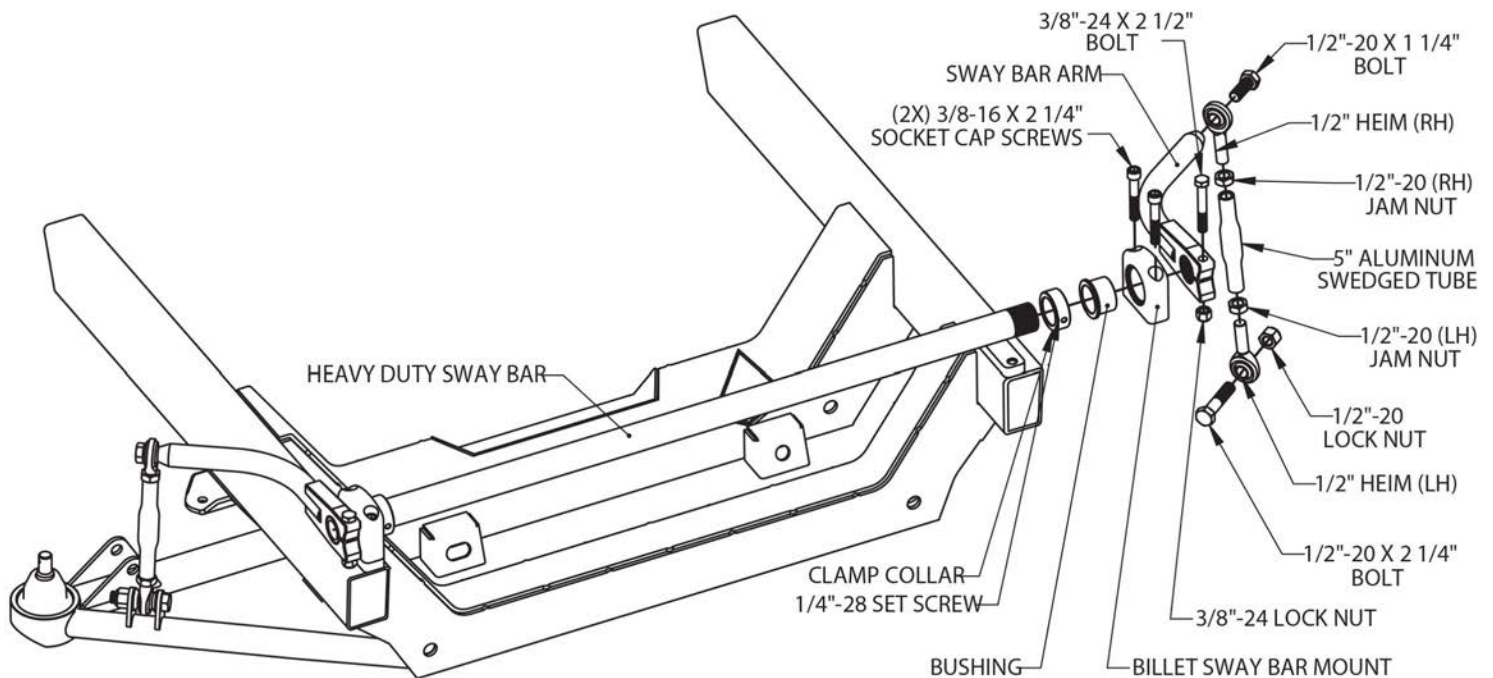

9. Install the brake kit to the hub per the instructions included with your brake kit.

NOTE: For recommended part numbers please visit our website or contact one of our tech experts.

INSTRUCTIONS



© 2025, Speedway Motors, Inc.

10. Mock up engine and transmission and install mounts as required. At this time, the front end can be reassembled. Some fabrication will be required to mount front fenders supports, radiator and front bumper brackets. All accessories and other components can now be installed.

11. Alignment. The lower control arms should be level with all the weight on the car. To adjust the ride height, take the weight off the suspension and turn the threaded adjusters on the coil over shocks. Once the ride height has been set, place the car back down on level ground. Adjust the free heim end on the sway bar link so that it lines up with the bracket in the lower control arm. Keep adjusting the heim end until the remaining 1/2"-20 x 2-1/4" bolt will slide through easily. Secure it with the 1/2"-20 lock nut and tighten.

Set the alignment to the following initial settings:

Caster = 5°

Camber = Street: Negative .25°-.5°

Race: Negative 1.5°-3.0°

Toe = 0" - 1/8" Toe Out

12. Caster adjustments are made by changing the caster inserts. The caster inserts are identified with numbers indicating the distance of the hole from the center of the insert in 1/8" increments.

#1 = 1/8"

#2 = 1/4"

#3 = 3/8"

The inserts can be reversed to move the hole in front of or behind center for a total adjustment of 3/4".

13. Camber is adjusted using the included A-arm shim plates. Additional shim plates can be purchased separately if desired under Speedway Part # 917-21005. These are available in thicknesses ranging from 1/8" to 1/2".

INSTRUCTIONS

© 2025, Speedway Motors, Inc.



350-2000-62 - Universal G-Comp Subframe

Kit Contents	
P/N	Description
350-100.2	G-Comp Camber Shim Kit
350-1100	G-Comp X Edition Spindle Upright
350-2000.2	60-62" Subframe Weldment
350-2000.6	Hardware Kit - 62"
350-903	G-Comp Upper Control Arms +1"
350-904	G-Comp Lower Control Arms +1"
350-207	G-Comp X Hub Bolt Kit
350-350	G-Comp X Front Hub
910-35011	G-Comp Steering Arm - Pair
350-501	G-Comp 34" Standard Sway Bar
350-500.2	Sway Bar Kit
910-35341	New T-Bird Power Rack

This kit is designed as a performance upgrade to the OEM suspension system in almost any vehicle. This installation will involve fabrication and welding to connect the new subframe weldment to the existing structure of the vehicle. As such, this should only be attempted by an experienced fabricator familiar with this type of work.

Please read and understand these instructions completely before starting this project.

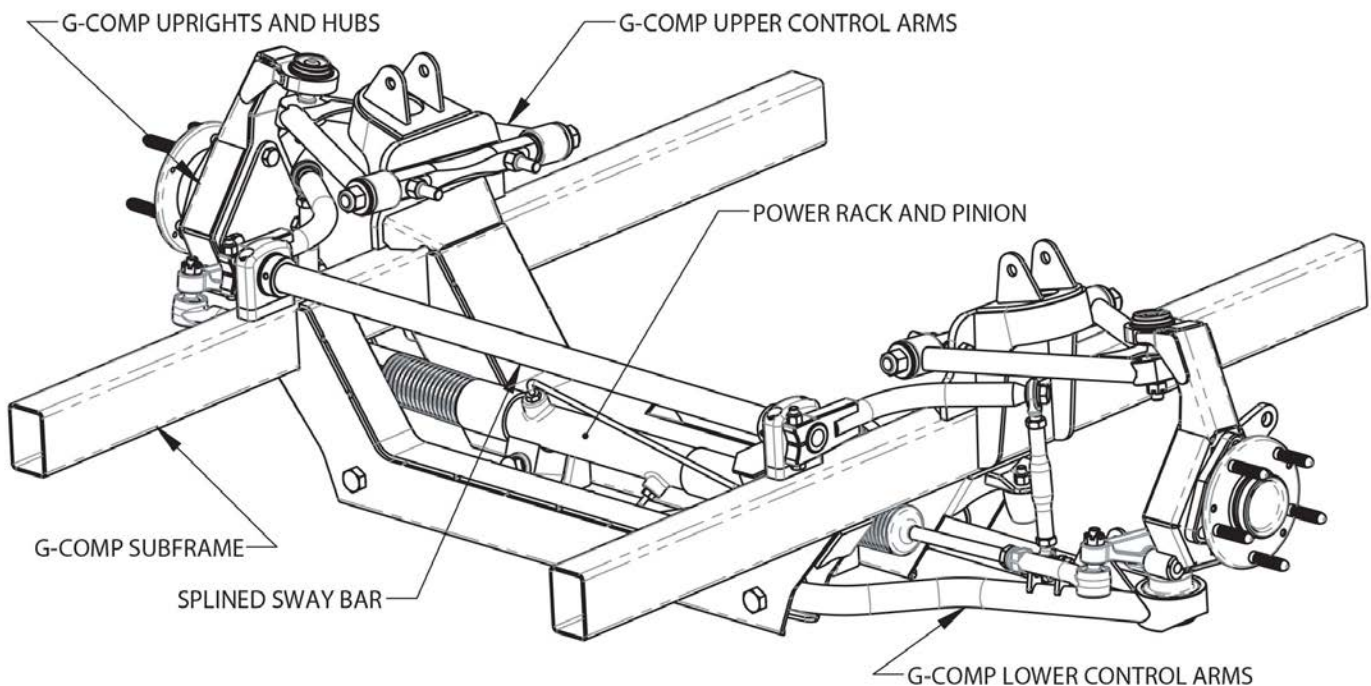

INSTRUCTIONS

© 2025, Speedway Motors, Inc.



To start, determine desired ride height based on the tire size you will be using. The axle centerline for this suspension is $3/4$ " above the lower surface of the frame rail at designed ride height and 26" back from the front edge of the subframe rail.

NOTE: This 26" dimension will vary slightly depending on how much caster you put in the suspension - more caster will move centerline back. Based on this, calculate the frame rail height dimension. For example: (see illustration below) if the proposed tire diameter is 28", then the centerline of the tire (spindle centerline) would be 14" ($28"/2$) above ground level. Subtracting the $3/4$ " from the 14" leaves the lower surface of the rail at 13- $1/4$ " above the ground. Now, substitute your desired tire diameter into this formula to calculate your frame rail height. Mock the vehicle up at your desired ride height and determine the best way to attach the subframe weldment to the existing structure of the vehicle while maintaining this relationship. In the case of a full frame car, cutting the existing frame near the firewall and fabricating a 2x3 (or similar) tube rail to attach the subframe to the existing structure is an option.

Depending on the condition of the existing frame or plans for the rear suspension, it may also be easier and better to fabricate an entirely new full frame. On unibody type vehicles, the job can be a bit tougher and require a bit more engineering. It is up to the fabricator to determine the best method to use and to ensure that the completed chassis is structurally rigid enough to handle the input loads that will occur as the vehicle is driven. If you are inexperienced in this type of fabrication, it is highly recommended that you seek the assistance of a professional shop that has experience in this area.

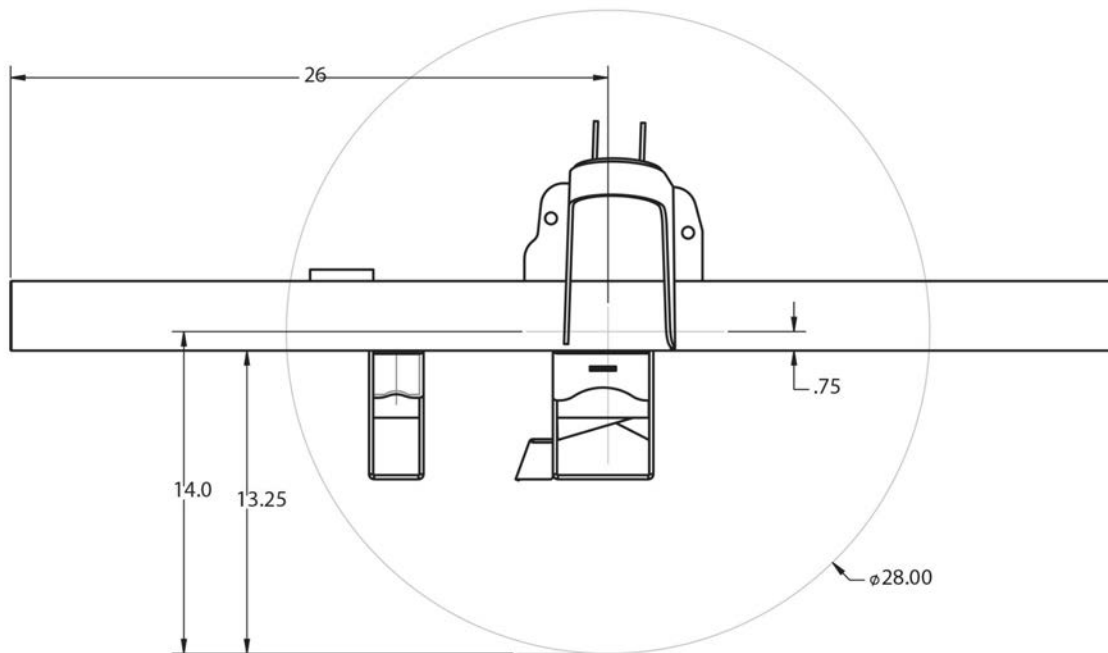

INSTRUCTIONS

SPEEDWAY
motors®

© 2025, Speedway Motors, Inc.

1. Steering Rack. This G-comp front suspension kit is designed to use a Thunderbird style power steering rack. Install the steering rack as shown, using the two 5/8"-18 x 3 1/2" bolts, washers and lock nuts.

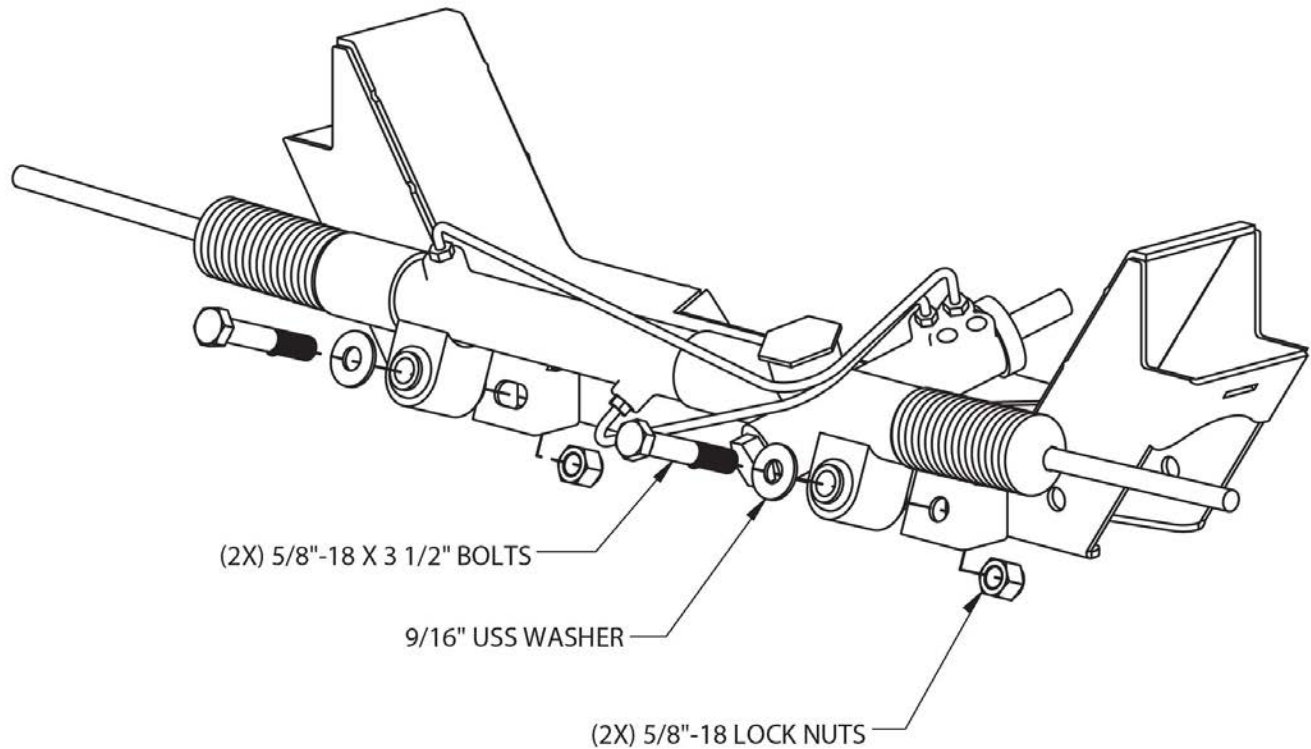

2. Install the lower control arms into the crossmember. Align the control arm bushings with the lower control arm holes in the crossmember. The front bolts, 5/8"-18 x 3-1/4" are to be installed from the front side. The rear bolts, 5/8"-18 x 5-1/2" are to be installed from the rear. Install the 5/8"-18 lock nuts and tighten. Install the lower control arm bump stops to the sub-frame using the supplied 3/8" lock nuts as shown.

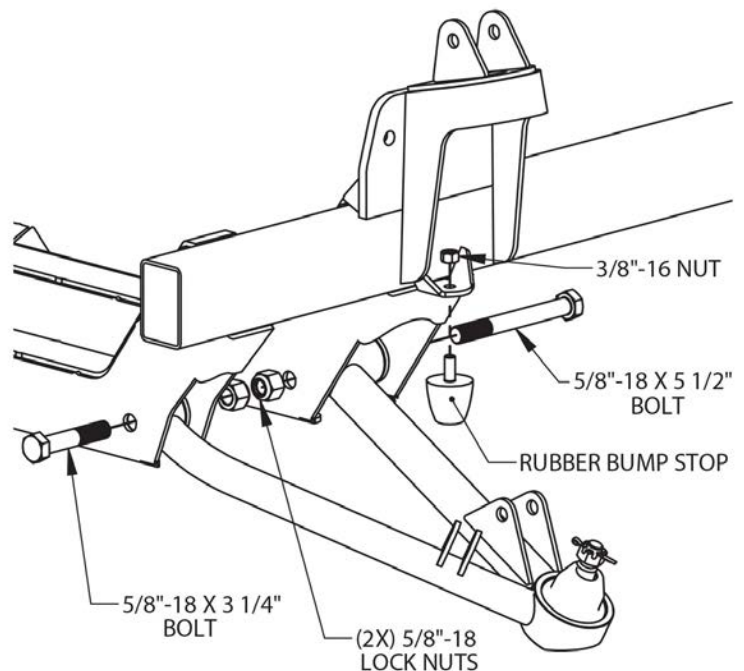

INSTRUCTIONS



© 2025, Speedway Motors, Inc.

3. Install the shocks. This procedure may vary slightly depending on the shocks used. Spin the adjusting collar onto the threaded shock body. Adjust the collar all the way to the bottom of the threads. Install the spring over the shock body.

NOTE: The G-Comp sub-frame has the upper spring retainer built into the sub-frame so the upper coil-over shock spring retainer is not used. Using the 1/2"-20 x 2-1/2" bolt and two 3/16" wide spacers, install the shock into the lower mount on the control arm. Secure it with a 1/2"-20 lock nut. Fully extend the shock and raise the lower arm so the upper shock mount and spring align with the shock mount and spring pocket on the sub-frame. Install the 1/2"-20 x 3" upper shock bolts and 7/16" wide spacers. Secure it with a 1/2"-20 lock nut.

NOTE: This kit is designed to use shocks with a compressed length of 10" and an extended length of 14". Shock ends should be 1/2" bearings with a mounting width of 1". For recommended part numbers, please visit our website or contact one of our tech experts.

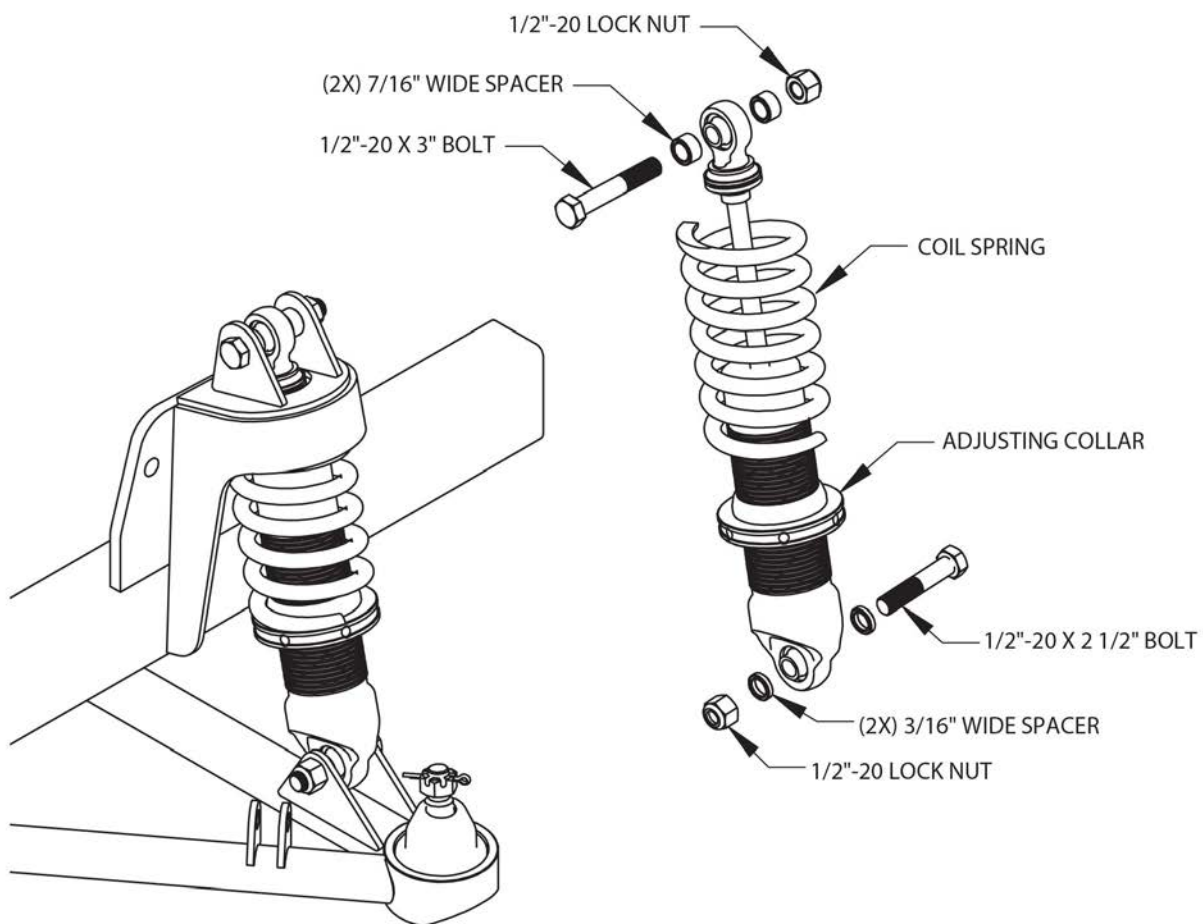

INSTRUCTIONS

SPEEDWAY
motors®

© 2025, Speedway Motors, Inc.

4. Mount the upper control arms to the sub-frame using the 1/2"-20 x 2-3/4" bolts and lock nuts. The optional 3" bolts (included) are to be used if needed to achieve more negative camber. Rotate the cross shafts so the caster shim pockets are facing toward the center of the vehicle. Install the bolts through the caster shims, cross shafts, and the sub-frame as shown. Then secure with the 1/2"-20 locknuts. For initial installation, install the #2 caster shim with the hole positioned to the front of the pocket. This should give a good initial starting point for alignment.

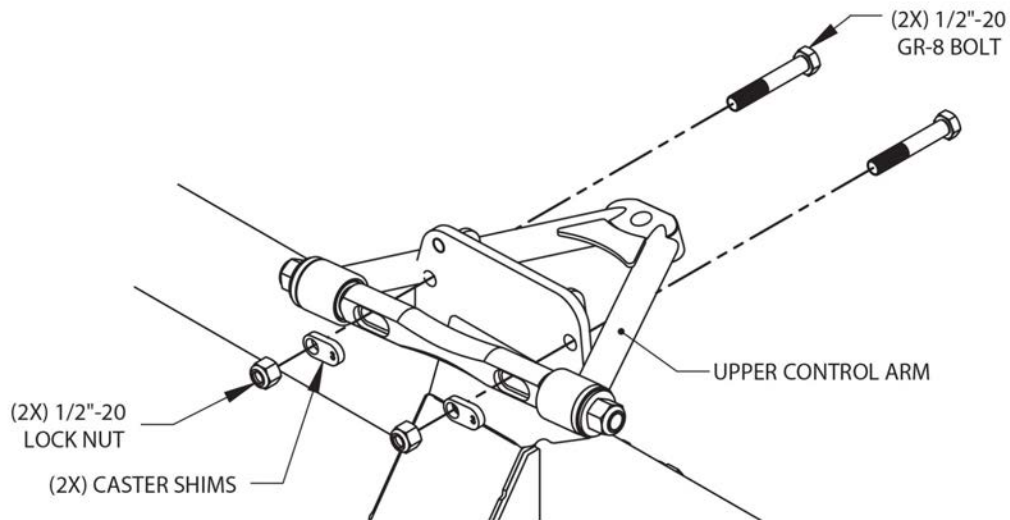

5. Install the uprights and steering arms. Install the upright onto the lower ball joint. Install and tighten the supplied castle nut. Repeat with the upper ball joint and install the cotter pins. Bolt the steering arms to the spindles using the 1/2"-20 x 1-3/4" bolts.

NOTE: Make sure to use Loctite on the threads.

6. Install the hubs. The Corvette style hubs included with this kit use metric hardware, including metric lug nuts. Using the supplied M12 metric bolts and Loctite, secure the hubs to the uprights. The fit of the hub into the upright is a close tolerance fit. It may be required to remove any paint or powder coating from the inner bore of the upright before assembly.

7. Install the outer tie rod ends and jam nuts onto the inner tie rods of the rack. Thread both tie rod ends on equally. Attach the tie rod ends to the steering arms using the castle nuts supplied with the tie rod ends. Tighten and install the cotter pins. Final alignment will be done at a later time.

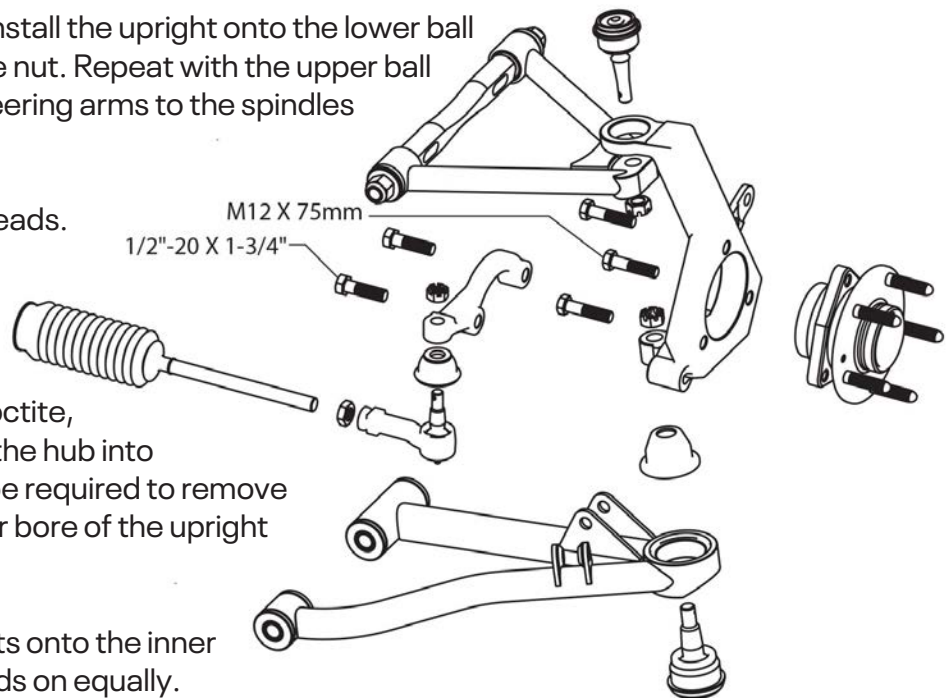

INSTRUCTIONS

© 2025, Speedway Motors, Inc.



8. Sway bar assembly: Press the bushings into the aluminum pillow blocks and install the pillow blocks to the front crossmember with the bushing shoulder to the inside. Use the four 3/8"-16 x 2-1/4" socket head cap screws to secure the pillow block to the subframe. Before fully tightening the bolts, slide the sway bar through the bushings, installing the two clamp collars to the inside of both pillow blocks. Now, tighten the 3/8" socket cap screws. Center the sway bar between the pillow blocks. Slide one clamp collar up against the bushing shoulder in the pillow block and tighten the set screw. Slide the second clamp collar up to the opposite bushing in the pillow block leaving about .075" of side clearance between the clamp collar and the bushing. Tighten the set screw.

NOTE: A nickel is about .075" thick and can be used as a spacer between the clamp collar and the bushing to provide the proper side clearance. Slide the sway bar arms onto the splined ends of the sway bar aligning them flush with the end of the bar. Make sure they are parallel or "clocked" to one another then tighten the 3/8"-24 x 2-1/2" pinch bolts and lock nuts. Assemble the sway bar links as shown, leaving roughly 1/4" of threads showing on either heim joint. Use the 1/2"-20 x 1-1/4" bolts to secure the sway bar link to the sway bar arm.

Mount one of the lower links into the bracket on the lower control arm using a 1/2"-20 x 2-1/4" bolt and secure it with the 1/2"-20 lock nut. Leave the bolt out of the lower link on one side at this time. The second bolt/nut will be installed after the ride height is set and the car is setting on level ground. This will ensure that there is no preload on the sway bar at ride height.

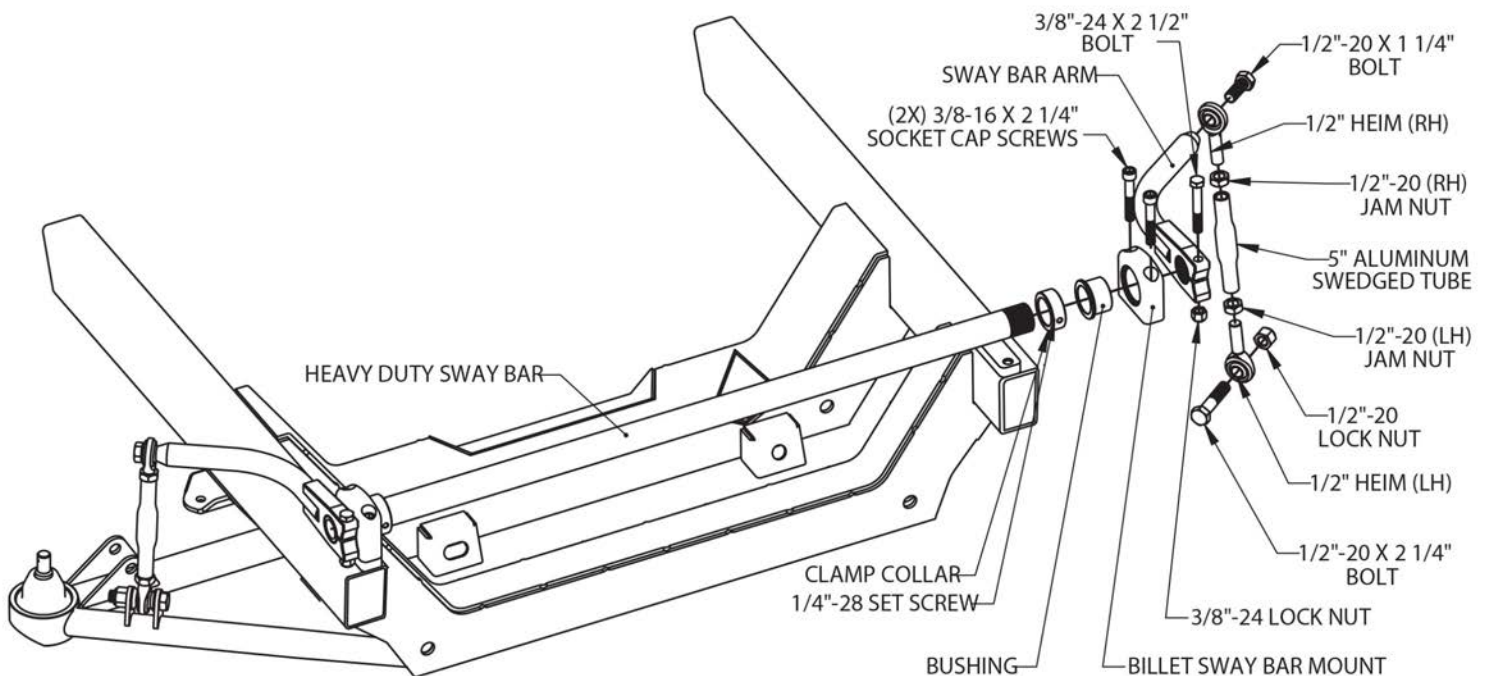

9. Install the brake kit to the hub per the instructions included with your brake kit.

NOTE: For recommended part numbers please visit our website or contact one of our tech experts.

INSTRUCTIONS



© 2025, Speedway Motors, Inc.

10. Mock up engine and transmission and install mounts as required. At this time, the front end can be reassembled. Some fabrication will be required to mount front fenders supports, radiator and front bumper brackets. All accessories and other components can now be installed.

11. Alignment. The lower control arms should be level with all the weight on the car. To adjust the ride height, take the weight off the suspension and turn the threaded adjusters on the coil over shocks. Once the ride height has been set, place the car back down on level ground. Adjust the free heim end on the sway bar link so that it lines up with the bracket in the lower control arm. Keep adjusting the heim end until the remaining 1/2"-20 x 2-1/4" bolt will slide through easily. Secure it with the 1/2"-20 lock nut and tighten.

Set the alignment to the following initial settings:

Caster = 5°

Camber = Street: Negative .25°-.5°

Race: Negative 1.5°-3.0°

Toe = 0" - 1/8" Toe Out

12. Caster adjustments are made by changing the caster inserts. The caster inserts are identified with numbers indicating the distance of the hole from the center of the insert in 1/8" increments.

#1 = 1/8"

#2 = 1/4"

#3 = 3/8"

The inserts can be reversed to move the hole in front of or behind center for a total adjustment of 3/4".

13. Camber is adjusted using the included A-arm shim plates. Additional shim plates can be purchased separately if desired under Speedway Part # 917-21005. These are available in thicknesses ranging from 1/8" to 1/2".