

SHiFTWORKS®

“Classic Appearance meets Modern Performance”

Thank you for your purchase!

With any questions regarding your purchase, products, or installation do not hesitate to reach out to us:

Phone: (585) 924-2700

Email: Support@shiftworks.com

Horseshoe Shifters



1968-69 Camaro

1968-69 Impala

1968-72 Chevelle
1968-72 El Camino
1970-72 Monte Carlo

1970-72 Camaro

This Document Will Cover Conversion Kits and Shifter Packages.

* Always verify you have purchased the correct kit for your application BEFORE beginning your installation!!!

Conversion Kits		
	1968-72 Universal/Impala	1968-70 Chevelle/El Camino
TH350 & TH400	C350 C350-CS C350-R C350-R-CS C350-RVB C350-RVB-CS	C350-2 C350-2-CS C350-2R C350-2R-CS C350-2RVB C350-2RVB-CS
700-R4, 4L60E, 4L70E	SC224 SC224-CS SC224-R SC224-R-CS SC224-RVB SC224-RVB-CS	SC2242 SC2242-CS SC2242-R SC2242-R-CS SC2242-RVB SC-2242-RVB-CS
4L80E & 4L85E	SC225 SC225-CS SC225-R SC225-R-CS SC225-RVB SC225-RVB-CS	SC2252 SC2252-CS SC2252-R SC2252-R-CS SC2252-RVB SC2252-RVB-CS
6L80E, 6L90E, 8L90E	SC261 SC261-CS	SC2612 SC2612-CS

Conversion Kits

	1971-72 Chevelle/ 1970-72 Monte Carlo	1968-69 Camaro	1970-72 Camaro
TH350 & TH400	C350-3 C350-3-CS C350-3R C350-3R-CS C350-3RVB C350-3RVB-CS	C350-4 C350-4-CS C350-4R C350-4R-CS C350-4RVB C350-4RVB-CS	C350-5 C350-5-CS C350-5R C350-5R-CS C350-5RVB C350-5RVB-CS
700-R4, 4L60E, 4L70E	SC2243 SC2243-CS SC2243-R SC2243-R-CS SC2243-RVB SC2243-RVB-CS	SC2244 SC2244-CS SC2244-R SC2244-R-CS SC2244-RVB SC2244-RVB-CS	SC2245 SC2245-CS SC2245-R SC2245-R-CS SC2245-RVB SC2245-RVB-CS
4L80E & 4L85E	SC2253 SC2253-CS SC2253-R SC2253-R-CS SC2253-RVB SC2253-RVB-CS	SC2254 SC2254-CS SC2254-R SC2254-R-CS SC2254-RVB SC2254-RVB-CS	SC2255 SC2255-CS SC2255-R SC2255-R-CS SC2255-RVB SC2255-RVB-CS
6L80E, 6L90E, 8L90E	SC2613 SC2613-CS	SC2614 SC2614-CS	SC2615 SC2615-CS

Shifter Packages

	<i>1968-69 Camaro</i>	<i>1970-72 Camaro</i>	<i>1968-70 Chevelle/ El Camino</i>	<i>1971-72 Chevelle/ 1970-72 Monte Carlo</i>
<i>TH350 & TH400</i>	SW1001 SW1001-R SW1001-RVB	SW1002 SW1002-R SW1002-RVB	SW1003 SW1003-R SW1003-RVB	SW1004 SW1004-R SW1004-RVB
<i>700-R4, 4L60E, 4L70E</i>	SW1011 SW1011-R SW1011-RVB	SW1012 SW1012-R SW1012-RVB	SW1013 SW1013-R SW1013-RVB	SW1014 SW1014-R SW1014-RVB
<i>4L80E & 4L85E</i>	SW1021 SW1021-R SW1021-RVB	SW1022 SW1022-R SW1022-RVB	SW1023 SW1023-R SW1023-RVB	SW1024 SW1024-R SW1024-RVB
<i>6L80E, 6L90E, 8L90E</i>	SW1025	SW1026	SW1027	SW1028

Parts Overview:

Shift Control Levers:



Transmission Cable Brackets: *3 and 4 Speed Pan Brackets*

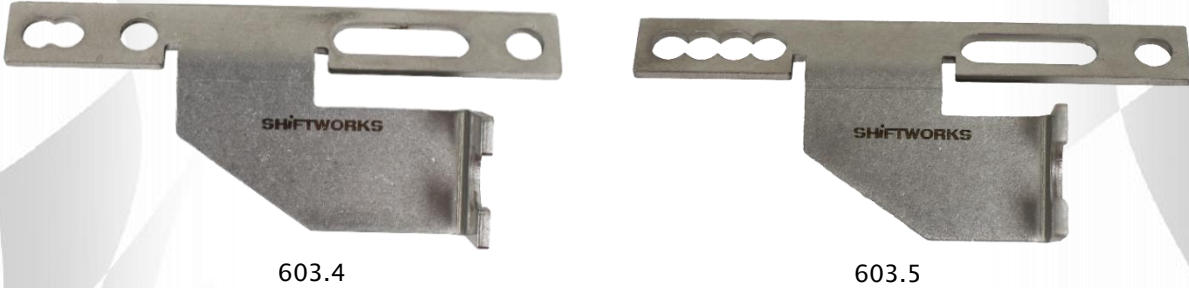

6 and 8 Speed Case Bracket



Detents:

3 Speed Detents:



640



DT3



RVB DT3

4 Speed Detents:



609



DT4



RVB DT4

6 and 8 Speed Detent:



640.6

Hardware Overview:

This is an overview of the hardware items you can expect to find in your Shiftworks shifter conversion kit.



Cable Clip



Cable Adjuster
Pin



M10x1.5 Hex
Nut



1/4-20 Cap
Screw



Small Washer



Lock Washer



Sheet Metal
Screw



Cotter Pin



M8x1.25 Hex
Bolt



Cable Eyelet
Retainer

Required Tools for Installation

This is a list of typical tools required to complete this job. Additional tools may be required depending on your application.

- Metric socket set
- SAE socket set
- Standard wrench set
- Pliers
- Drill
- 1/4" Drill Bit
- Phillips & Flat-head screwdrivers

Preliminary steps:

Before installing and adjusting your shifter assembly, follow these steps to ensure you have the best adjustment for your shifter and installation process.

1.) Chock wheels and disconnect the vehicles battery

Safety is always the most important step. When installing this kit, it is important to properly chock wheels to ensure the vehicle will not roll or move while clicking through the transmission gears. Additionally, disconnect the vehicles battery before continuing.



Figure 1

2.) **Adjust both bulkheads on the shifter cable to be in the center of their threads.**

Setting your Shiftworks cable bulkhead to the center of their threads will help later with your cable adjustment.

Simply turn the bulkheads until they are in the middle of the threads. These bulkheads are used for fine adjustments.



Figure 2

3.) **Remove the center console to gain access to your shifter assembly**

Remove the center console and surrounding trim to gain access to your shifter assembly. Refer to the factory service manual for details on how to properly remove the console.



** If you have purchased and are using a Shiftworks horseshoe shifter, skip to step 6.*

4.) **Removing the Factory Detent**

The current detent will need to be removed. It will be fastened to the shifter with either two bolts, or one bolt and a rivet.

If two bolts are present, simply unbolt the factory detent and remove from the assembly.

If one bolt and a rivet are present, remove the bolt first. Then, using a drill and a ¼” drill bit, drill out the factory rivet holding the original detent onto the shifter base and remove from the assembly [see Fig. 3].



Figure 3

5.) Installing and adjusting the new Shiftworks Detent

Your new Shiftworks detent will be installed using the following provided hardware [see Fig. 4].

- (2) ¼ Cap Screws
- (2) Lock washers
- (1) Small Washer



Figure 4

Loosely install the front and rear hardware to hold the gate in place.

Then adjust the front (park end) of the gate as high as the slot will allow while still allowing the handle cross bar to be able to clear the raised stop between park and reverse [see Fig 5].

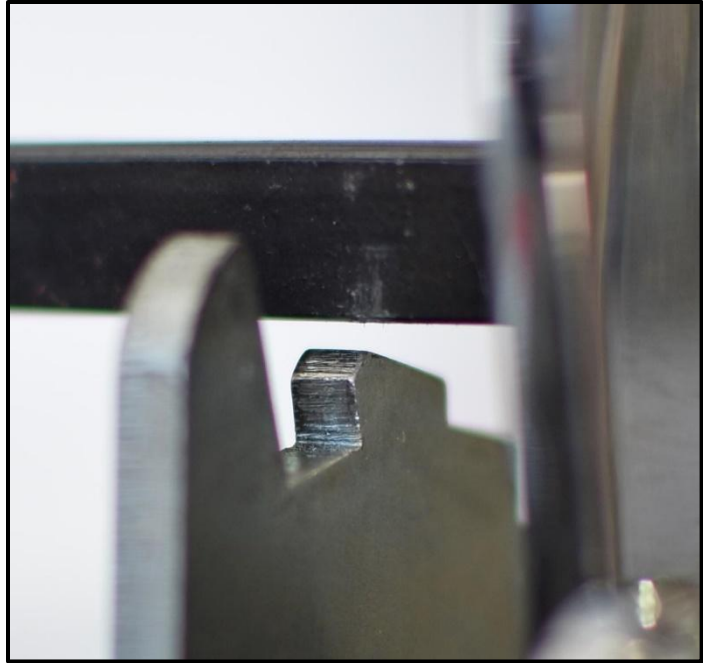

Figure 5

Once adjusted, tighten the front bolt first to hold the adjustment, then final tighten the rear bolt.

Before proceeding further, check that the shifter will still move through its entire range of motion and properly engages with all gear positions and stops.

Wiring Instructions

S9229

Neutral Safety / Backup light Switch

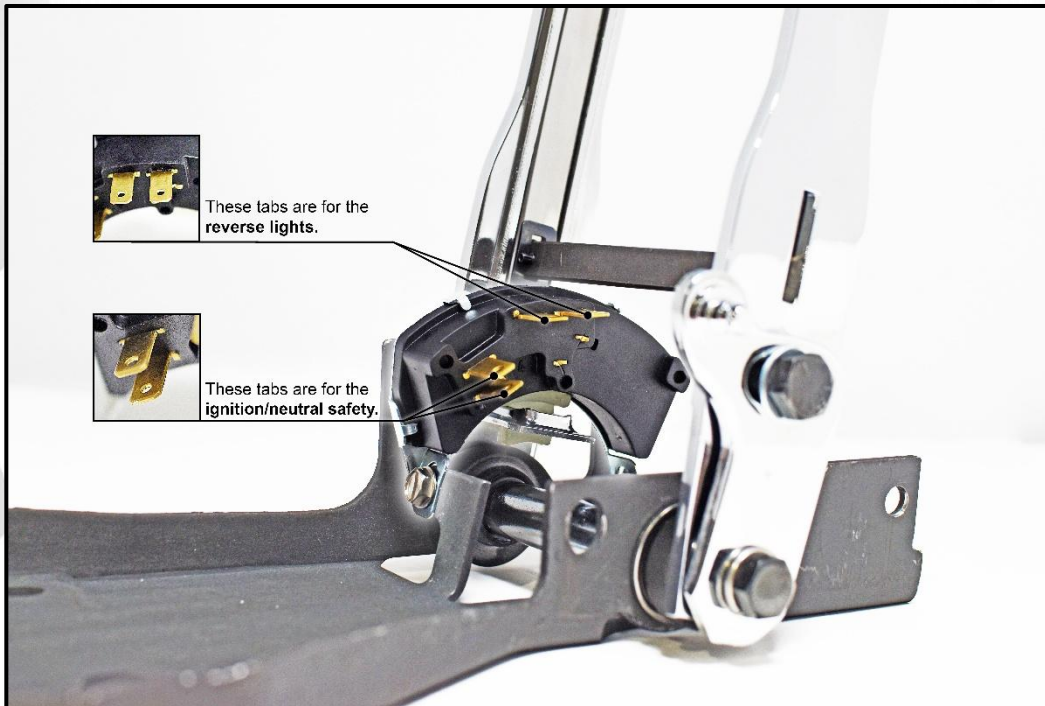

This replacement neutral safety switch installs directly onto the factory tabs of your GM shifter base. It fits a range of GM automatic transmissions, including Powerglide, 3-speed, 4-speed overdrive, and 6-speed models

Note: This switch operates by opening or closing the electrical path. There is no special "in" or "out" side. Both terminals in each pair function the same way. You can wire it in either direction and it will operate correctly.

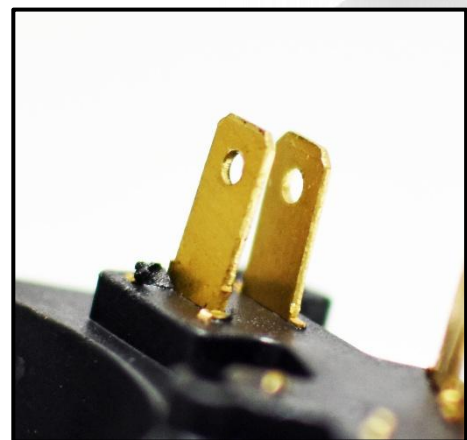

6.) Install Shift Control Lever

In your Shiftworks conversion kit, you will receive a new shift control lever that attaches to the transmission's select shaft. The select shaft length can vary between short and long ranges depending on the transmission. Typically, the TH350, TH400, 200-4R, and 700R4 use a short-range select shaft. The 4LE series transmissions can vary between a short or long-range shaft, while 6-speed and 8-speed transmissions generally feature a short-range shaft.

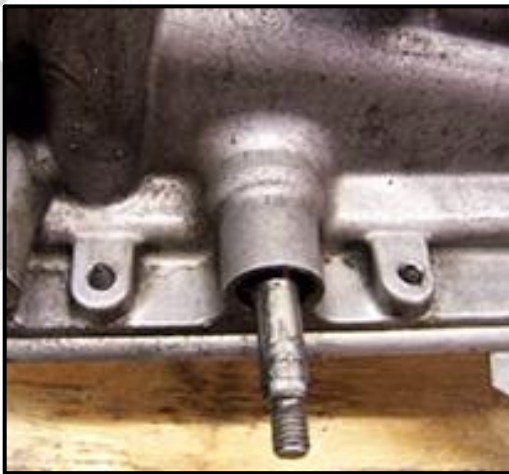

Long Range Select Shaft



Short Range Select Shaft

Figure 6

To remedy this some of our kits come with an additional shift control lever. Shift control levers are always installed with the "Shiftworks" logo facing outwards away from the transmission. Install your Shiftworks shift control lever by matching the cutouts on the shaft to the opening on lever. Then install and tighten the M10 x 1.5 nut



Figure 7



Correct – Long Shaft

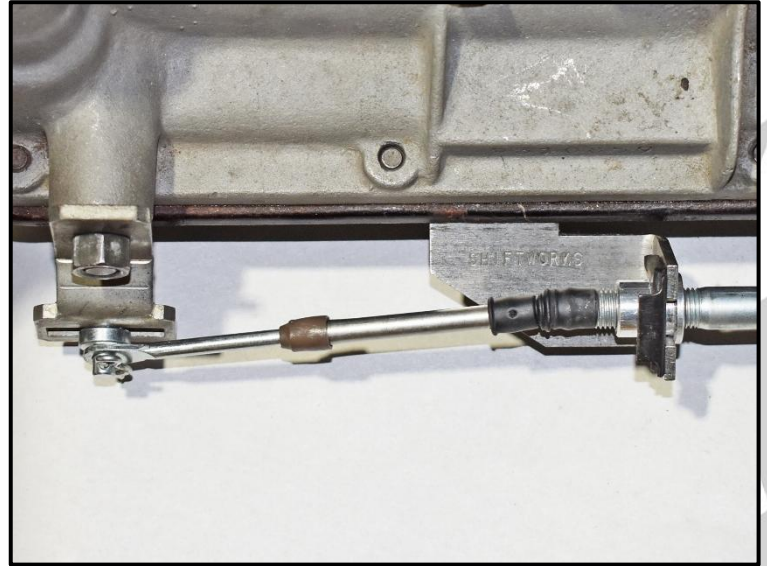

Correct – Short Shaft

Figure 8

Incorrect Applications

Making sure you install the range select shaft and the shift cable correctly is important to the functionality of your shift linkage as well as the longevity of the components. Be sure to install correctly and please contact Shiftworks customer service at (585) 924-2700 or email support@shiftworks.com with any questions.



Incorrect

Figure 9

This is the **incorrect** lever for the long range select shaft. As you can see by the steep angle in the cable. This can cause resistance and binding in the shifter linkage.



Incorrect Figure 10

This is incorrect because the cable adjuster pin is backwards on the shift control lever. This will typically damage the cable eyelet when attempting to force into park.



Incorrect Figure 11

This is incorrect because the cable adjuster pin is backwards on the shift control lever and can lead to the cable binding when shifting out of park.

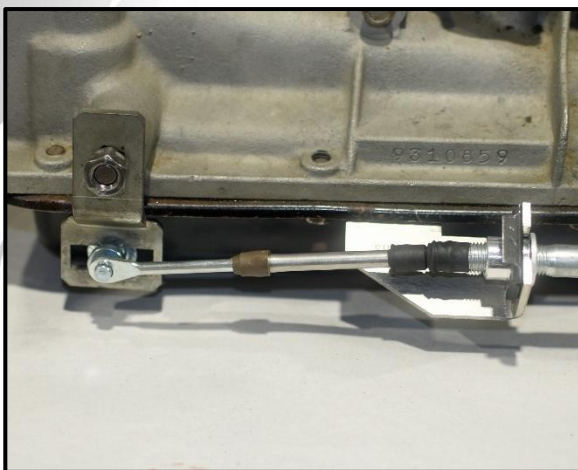

Incorrect Figure 12

This is incorrect due to the shift control lever being installed backwards. On all shift control levers the "Shiftworks" logo will be facing out.

7.) Install Transmission Cable Bracket

3 and 4 speed application

Remove the two transmission pan bolts and loosely install the Shiftworks transmission pan bracket. Please note the adjustment holes on the transmission pan bracket. Different holes and positioning are used for different applications. Please view the following diagram to see which adjustment holes are recommended for your application.

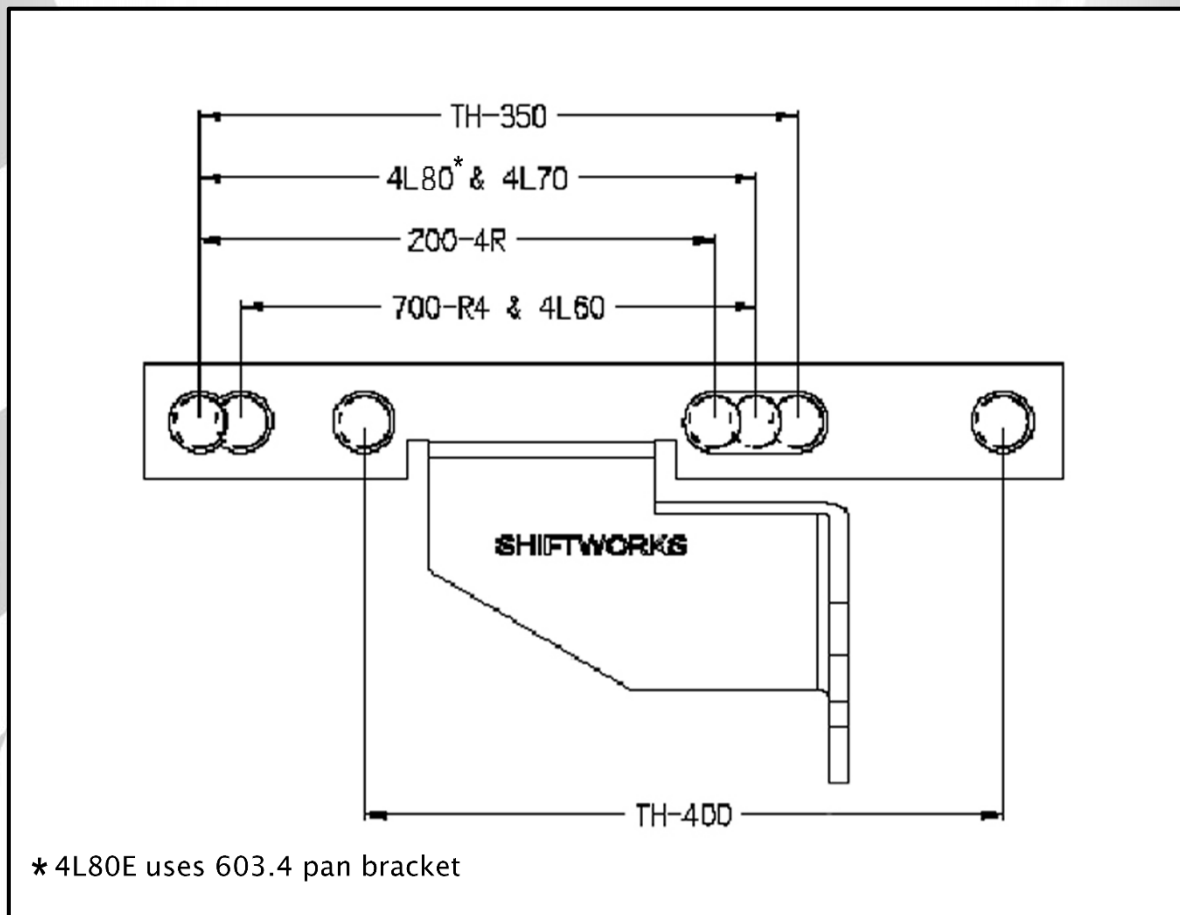

Figure 13

Tighten transmission pan bolts with bracket installed. **Make sure not to overtighten.** The transmission case is aluminum and will strip easily.

6 and 8 speed application

Install the transmission case bracket as shown in the illustration. Use the provided M8 x 1.25 hardware to fasten the case bracket.

Linkage adjustment:

1.) Set a baseline

Ensure that the shifter cable bulkheads are centered on the threads at both ends and that the pin on the shift control lever is centered.

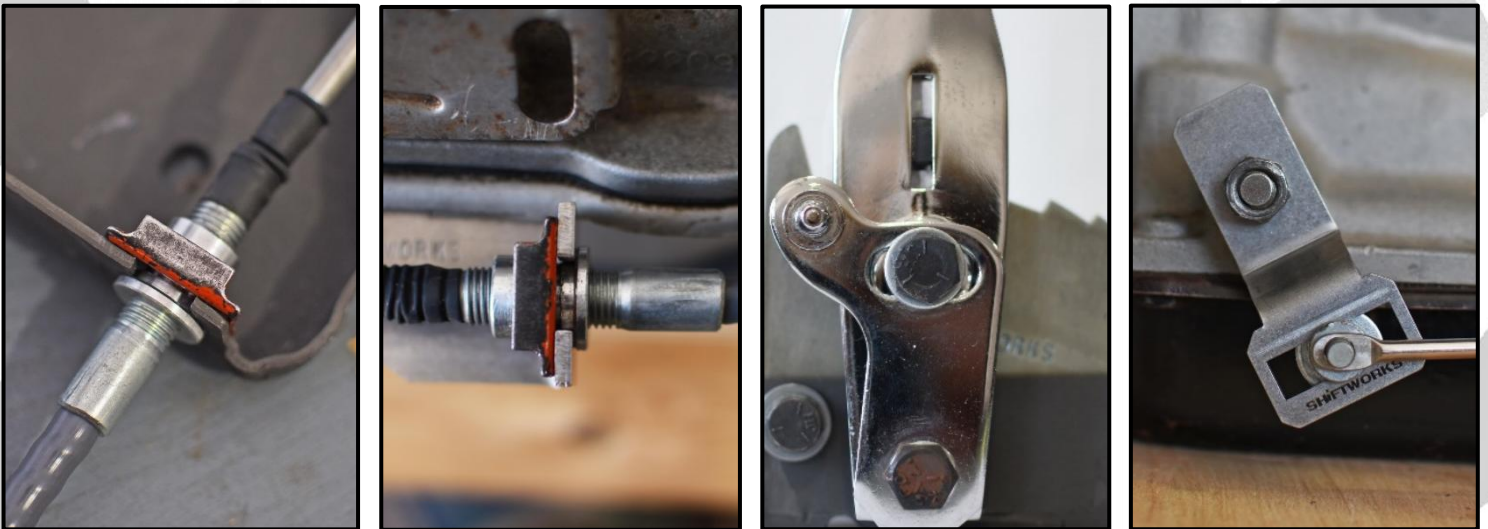

Figure 14

Baseline adjustments

Ensure the shifter cable bracket on the handle is set in the center of its adjustment slot and the hardware is tight [See Fig. 15].

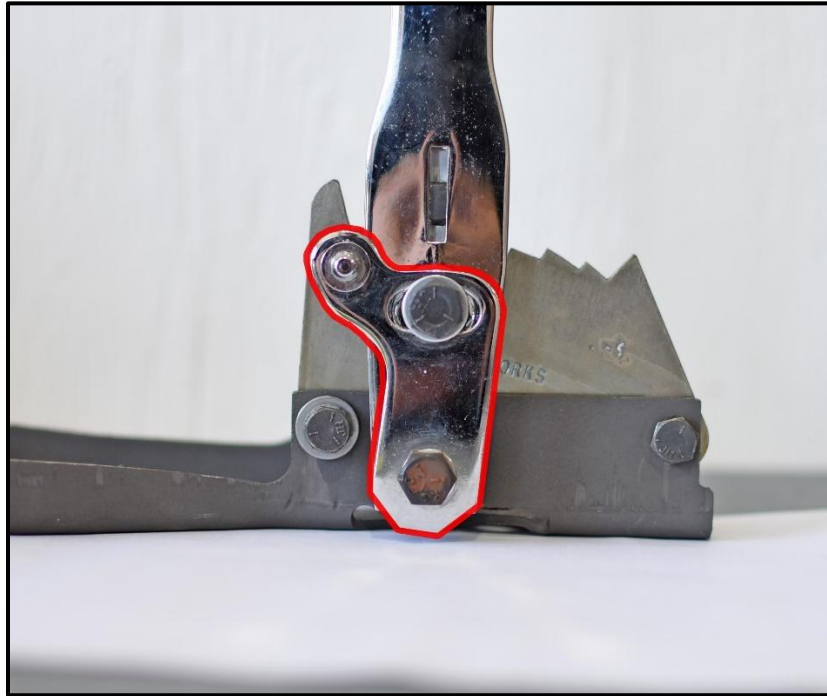

Figure 15

2.) Install cable with BOTH the shifter and transmission in neutral

With your transmission in park, (All the way forward towards the front of the car) move the shift control lever down 2 clicks to the neutral position [See Fig 16]. Then place your shifter in the neutral position as well [See Fig 17].



Figure 16



Figure 17

Install your cable into the car and connect linkage to the shifter first, then look at the cable at the transmission side.

The cable is adjusted by moving the pin on the shift control lever and the adjustment slots on the transmission pan bracket. Fine adjustment can be made with the bulkheads on the cables.

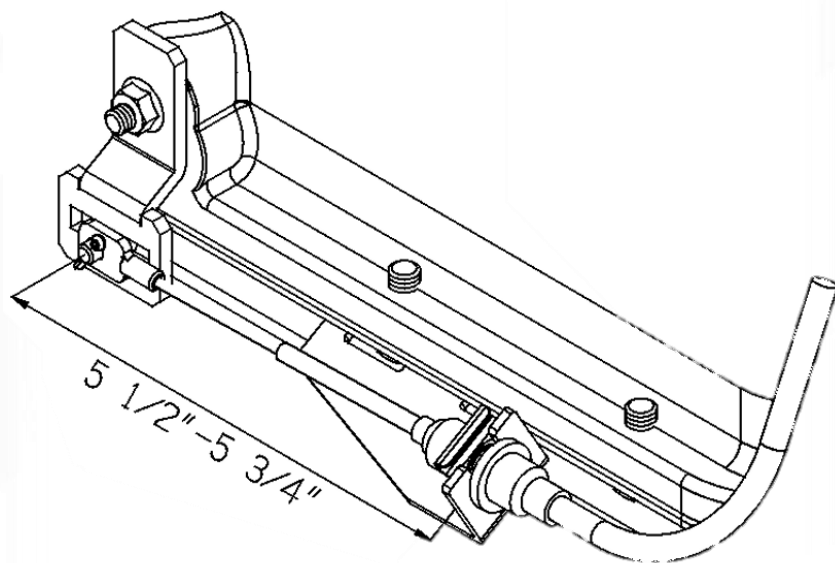

Figure 18

The cable eyelet and pin should be around 5 ½” to 5 ¾” to where the cable meets the transmission bracket. This measurement is taken in the neutral position. This measurement is a suggestion and could vary depending on application.

For TH400 Application:

Use the single non-slotted hole at the end of the transmission cable bracket [See Fig 19].

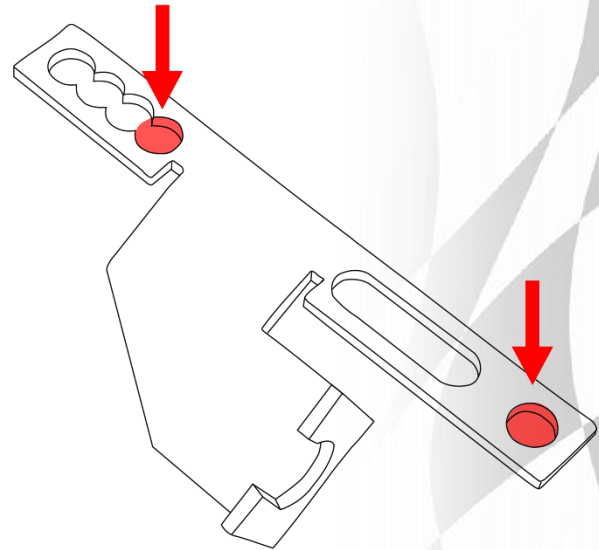

Figure 19

For 6-8 speed Application:

Attach the transmission cable bracket to the case as shown in the illustration to the right [Fig 20]. The suggested distance from the pin to the face of the case bracket should be around 5 ½” - 5 ¾”. This measurement can vary on different applications and is just a base measurement to aim for.

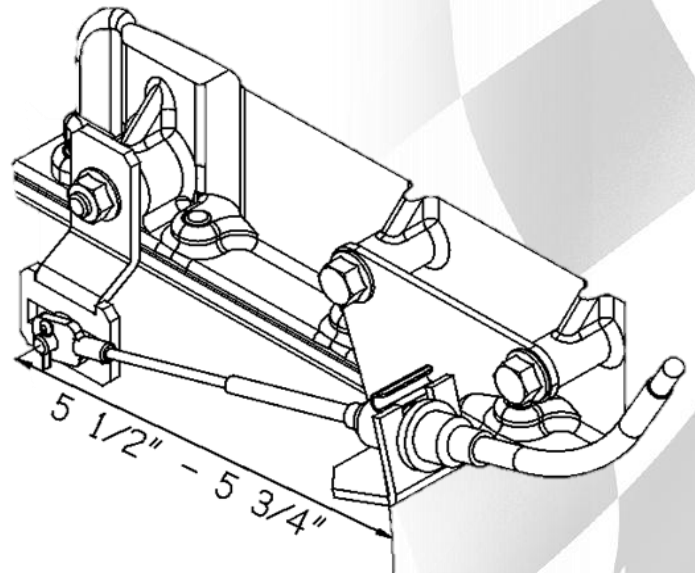

Figure 20

Cable Clip Installation:

One of the most common mistakes made installing a new cable is how the cable clips are installed. Installing these clips backwards can cause a loose fit and potential for the clip to come out. Be sure to install the clips the correct way as shown in the photos below [Fig 21].

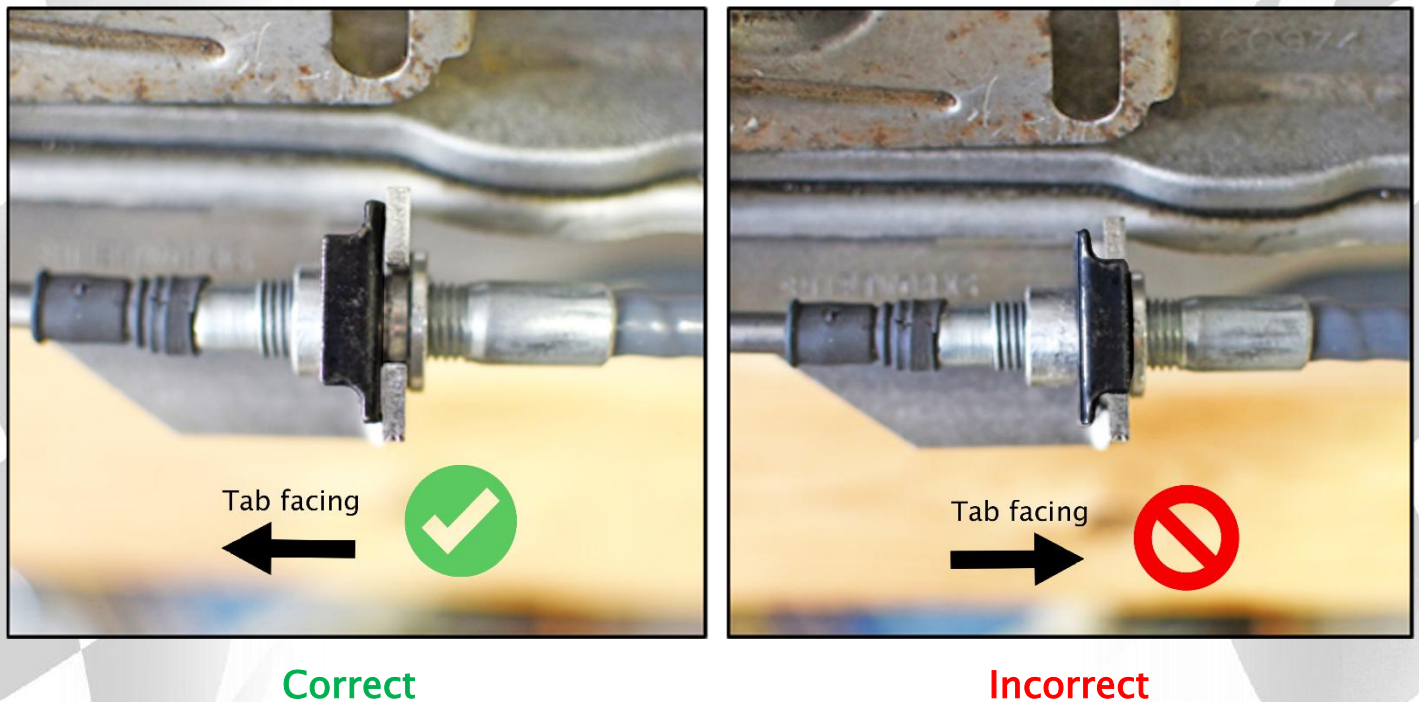

Figure 21

3.) Adjust Shift Cable:

Large adjustments should be made first with the cable pin on the shift control lever. Then adjust the bulkheads on the cables for fine adjustments. With both the transmission and shifter in neutral, adjust the shift cable so the cable eyelet can freely be removed from the pin on the shift control lever in any gear. There should be no resistance when taking the cable off the pin. By doing this procedure you are ensuring your transmission is fully in gear.

Ensure your transmission cable bracket is positioned properly, and make sure the shifter cable bracket on the side of the shifter is tight and positioned in the center of its slot.

Use Shiftworks cable #K100 Series or GM cable #3956765 only. No other cables are recommended.

If you are having difficulty setting up your shift linkage or have any other questions regarding products, please reach out to us. We are here to help.

Phone: 585-924-2700

Email: support@shiftworks.com

Social media:

Instagram: [@shiftworksshifters](https://www.instagram.com/shiftworksshifters)

Facebook: [Shiftworks, inc.](https://www.facebook.com/Shiftworks-inc)

Thank you for choosing Shiftworks!



www.shiftworks.com
© 1991-2024 SHIFTWORKS®