

Product Name: **FPR Range**
Product Description: FPR
Product Number: TS-0404-10XX/11XX
Document Version: V1.00 Rev B

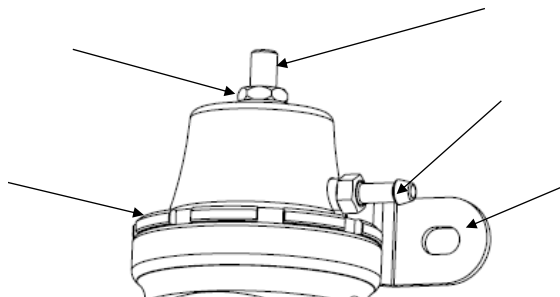

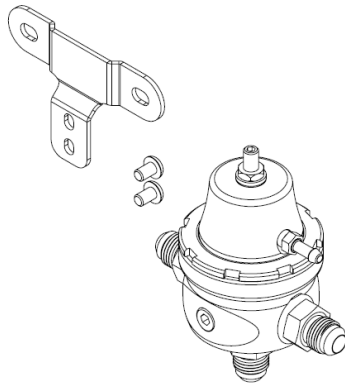

IMPORTANT NOTES ON YOUR FPR OVERVIEW

- cause serious engine damage if not checked fuel suitability.
- Use only high-quality fittings.
- Ensure that all plumbing is correct.
- Ensure that all plumbing is correct.
- Your fuel pressure regulator must be fitted with a Locknut.
- Gauge port is 1/8" NPT. M

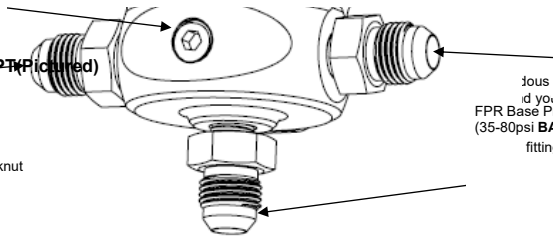

Adjust your fuel pressure regulator (35-80psi **BASE**) fitting your FPR.

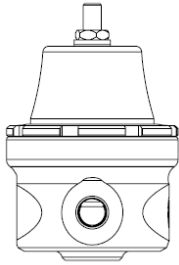

FPR 1-8 NPT (Tapered Thread)

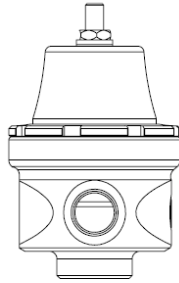

FPR -6AN ORB

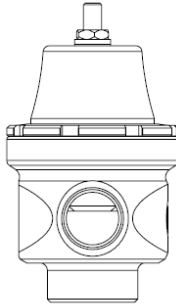

FPR -8AN ORB

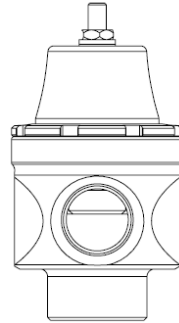

FPR -10AN ORB

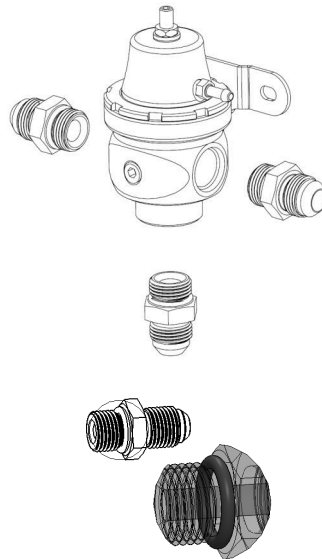

- Make sure that manifold reference port is sealed with a cap

FITTING YOUR FPR

Manifold Pressure Reference Port
Use fuel safe thread sealant

- RECOMM
- Turbo
 - Turbo
 - Non
 - Optior
 - Turbo

1. Locate fuel pressure feed line, base pressure and determine mounting location

This line is usually found by identifying your injectors, the fuel rail the injectors are mounted to and then the line that is feeding the fuel rail. Turbosmart

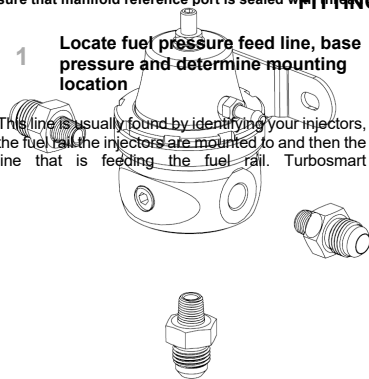

CAUTION: This fitting is fitted by an appropriately qualified technician once fuel pressure is installed to prevent high pressure and temperature fuel leaks which can lead to extremely dangerous fires. See across for example of ORB fitting – note the O-ring.

JEL P

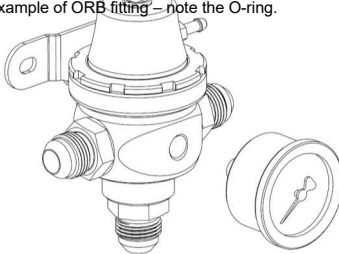

Mounting your FPR

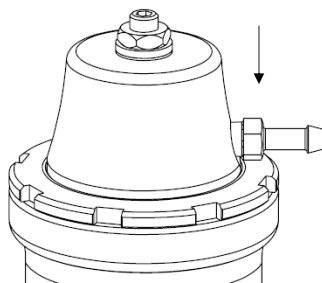
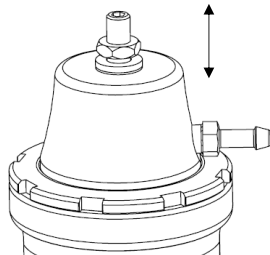
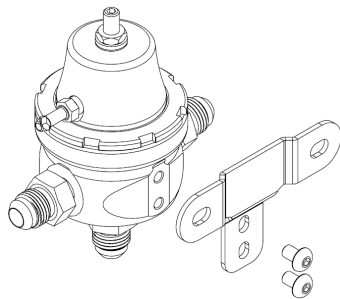

2 Prepare FPR for installation

pressure adjustments.

Prior to mounting the FPR, install fittings into FPR with high quality AN ORB fittings ensuring the O-Ring is present. Optional Turbosmart fitting is present. Optional Turbosmart fitting – TS-0402-11XX (NPT, -6 to -10 AN)

ADJUSTING YOUR FPR

Note! Remove signal reference hose and

3 Fit Gauge or Sensor Port (OPTIONAL)
CAUTION!

Priming procedure: Insert the FPR kit into each read
hub and connect the signal reference hose from
nipple and loosen 10mm locking nut on top of
FPR anti-clockwise to allow for free movement of the
adjuster screw.

2 Adjust base pressure

Avoid over-pressurizing the system, as this will
not allow for the devices to regulate fuel pressure
and can cause damage to your fuel pumps.
Apply thread lubricant and screw in clockwise until
finger tight, then tighten further 1-2 turns for seal.
Tighten 10mm locking nut and reconnect signal reference hose.
Turbosmart gauge kit (part no. P19-040-1002).

1 Once base pressure has been successfully set,
reconnect the signal reference hose and tighten the
10mm locking nut preventing the adjuster screw from

Ensure battery voltage is sufficient and the engine data logging device, turn the adjuster with a 3mm hex tool clockwise to increase fuel pressure and anti-clockwise to decrease fuel pressure. The example below is an increase in fuel base pressure.

s

