

INSTRUCTIONS

© 2024, Speedway Motors, Inc.

SPEEDWAY
motors®

560-6271 - 2 or 3 Carb Progressive Linkage

This universal linkage can be used in a variety of applications for multiple carb systems. The most common applications are on Stromberg and Holley 2 bbl carbs on 2x2 non-progressive and 3x2 progressive manifolds. It can also be used on progressive 2x4 manifolds as well as other types of carburetors with minimal modifications. These instructions will cover the basic setups, but due to the universal design of the linkage kit, is not intended to be all inclusive. Some fabrication or modification may be required.

Warning: It is the responsibility of the user that any modifications to throttle or carb linkage on their vehicles be done in such a manner as to assure positive spring return of throttle blades to avoid over rev of the engine or injury resulting from a stuck throttle.

Note: This linkage kit is designed for use on carbs with .280 diameter extended throttle shafts. If you are using original carbs with flush or capped shafts they will have to be modified with our extended throttle shafts or updated baseplates.

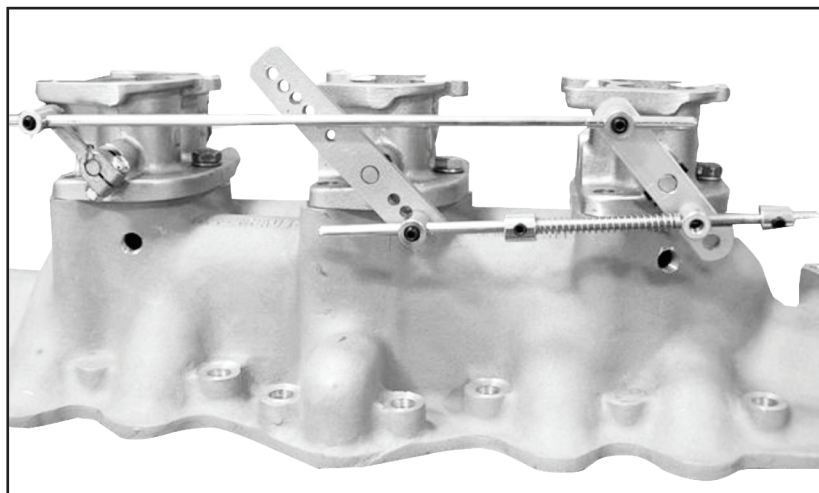

INSTRUCTIONS

© 2024, Speedway Motors, Inc.

SPEEDWAY
motors®

Three 2 BBL Progressive Set Up:

1. With throttle blades closed, install primary linkage arm on center carb shaft with 6-hole end up and arm angled forward at 45 degrees. Secure with set screws.

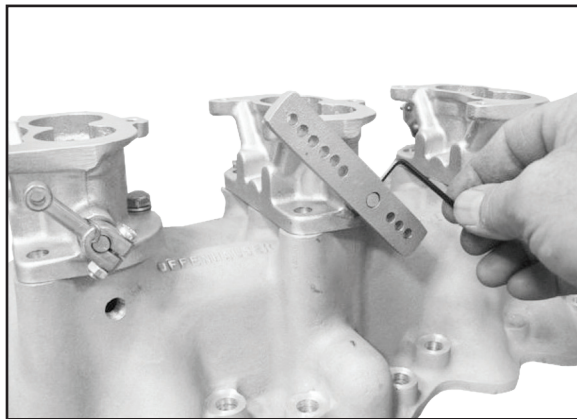

2. With throttle blades closed, install bellcrank arm on rear carb with 1-hole end up, angled forward at 45 degrees. Secure with set screws.

3. With throttle blades closed, install single arm on front carb shaft with link eye up, angled forward at 45 degrees. Secure with set screw.



4. With throttle blades of front and rear carb lightly seated in throttle bore, assemble the long linkage from the link eye of front carb to upper hole of rear carb bellcrank. Secure with set screws and install cotter pins.

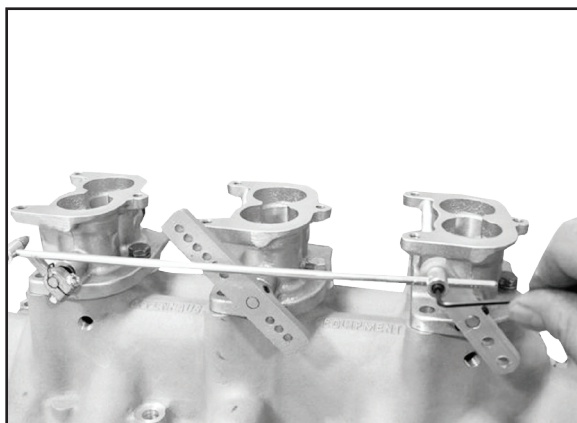

INSTRUCTIONS

© 2024, Speedway Motors, Inc.

SPEEDWAY
motors®

5. With center carb against idle stop screw, assemble short link from the lower hole of the center carb arm to the upper-lower hole on rear bellcrank carb arm. This provides a 1:1 ratio for all three carbs. To operate as a progressive linkage move the short linkage pivot on the rear carb arm to the upper hole (hole closest to the throttle shaft).

Adjustment Note: The center carb arm has 3 adjustment holes. The upper hole starts secondary carb opening early and brings them in slowly. The lower hole delays the secondary carb opening point and brings them to WOT quicker. Start with the linkage in the center hole and then tailor the secondary opening rate to suit your driving style. The throttle blades of the front and rear carb should remain lightly seated in throttle bores. Choke, idle speed and mixture adjustments are made on the center (primary) carb.

6. Remove set screw from linkage pivot of rear carb. Install adjustable slide stop on aft side of rear carb arm short linkage. Adjust slide stop so that all 3 carbs reach WOT at the same time. Tighten set screw on slide stop.

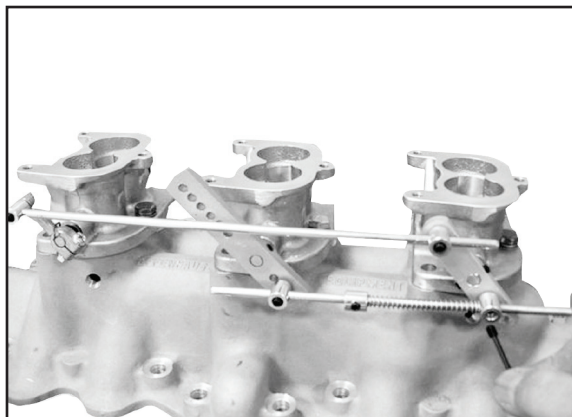

7. Connect vehicle throttle linkage to one of the upper holes of center carb arm (arm can be shortened for your application if desired). Connect return spring to suitable location making sure that it does not interfere with or cause binding of linkage.

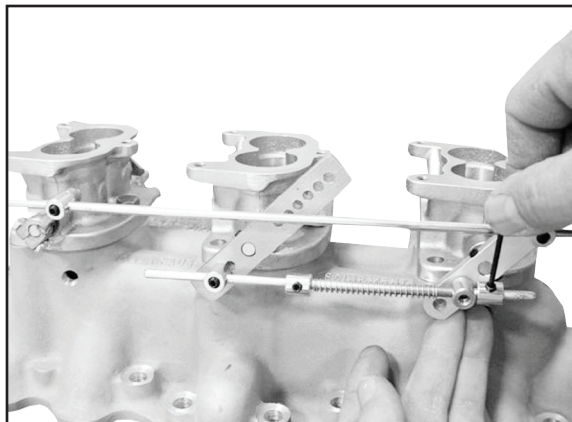

8. Loosen the spring tension slide stop. Move stop toward rear throttle arm to compress the secondary return spring approximately 1/2". Secure with set screw.

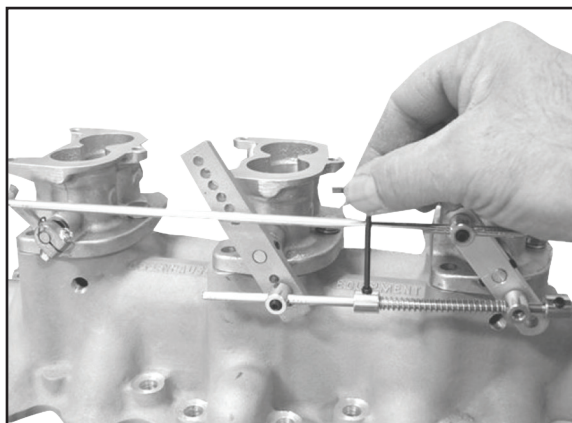

INSTRUCTIONS

© 2024, Speedway Motors, Inc.

SPEEDWAY
motors®

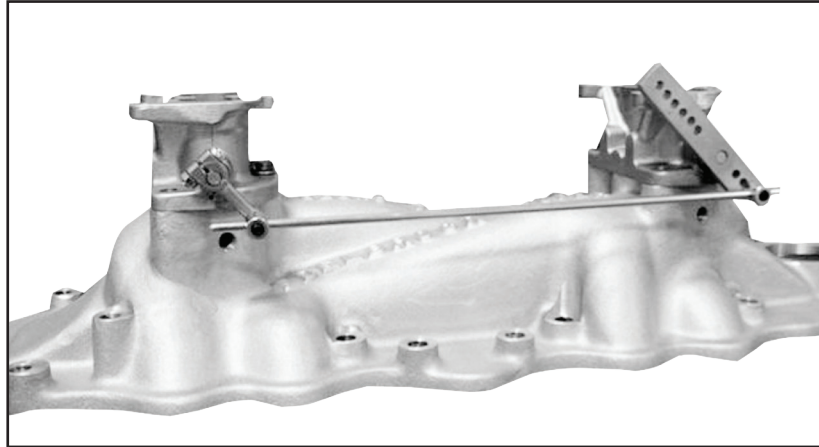

Two 2 BBL Non-Progressive Set Up:

1. Install primary linkage arm on drivers side of rear carb shaft with 6-hole end up and arm angled forward at 45 degrees. Secure with set screw.
2. Install single arm on front carb shaft with link eye facing down and aft at 45 degrees. Secure with set screw.
3. Back off idle screws of front and rear carb until the throttle blades of both carbs are lightly seated in the throttle bores. Assemble long linkage rod from link eye of front carb arm to lower hole of rear carb arm. Tighten set screws in the center of sliding link pivots to maintain required length and install cotter pins.
4. Connect vehicle throttle linkage into one of the upper holes of rear carb throttle arm, install return spring in suitable location to assure positive throttle return. Make certain that throttle pedal travels freely and allows carbs to advance to wide open throttle.

Note: If the throttle linkage of your particular vehicle dictates that the throttle pedal be connected to the front carb invert steps # 1 and 2.

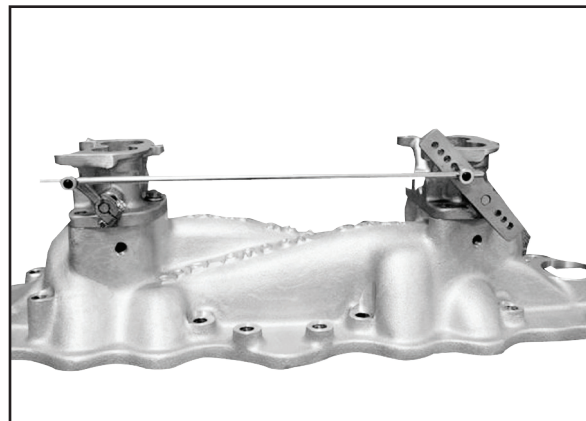
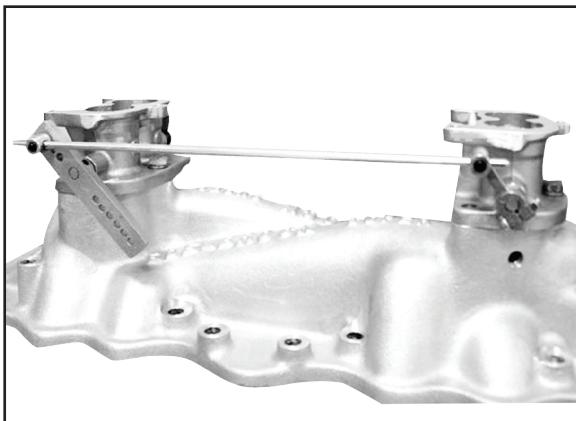

5. With throttle blades of both carbs closed adjust idle stop screws until they just contact the idle stop. After both carbs have been zeroed, adjust each idle screw 1 additional turn. Start engine and proceed with carb adjustment and synchronization.

Caution: If you adjust one carb to zero +1 turn and then adjust the other carb to zero +1 turn, the carbs will be out of sync. They must both be zeroed prior to any other adjustments. **4**