



an ISO 9001:2015 Registered Company

1982-88 GM G-Body (Non-Turbo)

Condenser Kit *with* Drier
(025082)



18865 Goll St. San Antonio, TX 78266
Phone: 800-862-6658
Sales: sales@vintageair.com
Tech Support: tech@vintageair.com
www.vintageair.com



www.vintageair.com

Table of Contents

Cover..... 1

Table of Contents..... 2

Packing List/Parts Disclaimer..... 3

Important Notice..... 4

Core Support Measurements, Engine Compartment Disassembly..... 5

Engine Compartment Disassembly (Cont.), Core Support Modification..... 6

Condenser Bracket Preparation and Installation (Stock Radiator)..... 7

Condenser Bracket Preparation and Installation (Larger Core Radiator)..... 8

Lubricating O-rings, Drier, Hardline and Hardline Support Bracket Installation..... 9

Drier, Hardline and Hardline Support Bracket Installation (Cont.)..... 10

Binary Switch Installation..... 11

Condenser Installation..... 12

Condenser Installation (Cont.), Final Steps..... 13

Packing List..... 14

Additional Info: Please Read Before Beginning

- **This kit was designed for the 1982-88 G-Body's. This kit may also fit 1978-81 G-Body's by doing some minor modifications. The main modification needing to be done, will be trimming the core support to allow clearance for the drier mounted on the front of the condenser.**



A detailed tech video outlining the installation process is available on Vintage Air's YouTube channel at <https://bit.ly/3vp5MQp>. Viewing the tech video along with the written instructions will provide the installer the most detailed installation procedure.



www.vintageair.com

Packing List: Condenser Kit (025082)

No.	Qty.	Part No.	Description
1.	1	03771-VUC	Condenser, 25 1/2" x 14", Parallel Flow
2.	1	07321-VUC	Drier
3.	1	11079-VUS	Binary Switch, Male
4.	1	23135-VUW	Compressor Lead
5.	1	41117-VUP	Refrigerant Oil
6.	1	182479	Screw, 10-24 x 1/2", Pan Head
7.	12	18249-VUB	Screw, 10-24 x 3/8", Pan Head
8.	13	18260-VUB	Nut with Star Washer, 10-24
9.	4	18247-VUB	Screw, #10 x 1/2", Sheet Metal
10.	3	182870	Bolt, 1/4-20 x 1/2", Flange Hex
11.	1	18125-VUB	Washer, 5/16"
12.	1	18152-VUB	Nut with Star Washer, 1/4-20
13.	4	33857-VUF	O-ring, #6
14.	2	33858-VUF	O-ring, #8
15.	1	31600-VUD	Adel Clamp, 3/8" I.D.
16.	1	31603-VUD	Adel Clamp, 1/2" I.D.
17.	1	091154	Hardline, #6 Drier/Condenser
18.	1	110790	Boot, Binary Switch
19.	2	226004	Butt Splice, 22-16 AWG
20.	2	226012	Heat Shrink, 1/4"
21.	48"	238013	Flexo Sleeve, 1/4"
22.	3	21301-VUP	Tie Wrap, 4"
23.	1	092078	Hardline, #6 Drier/Evaporator
24.	1	092079	Hardline, #8 Condenser/Compressor
25.	1	659981	Bracket, Condenser/Drier, Passenger-Side
26.	1	649600	Bracket, Lower Condenser
27.	1	649602	Bracket, Upper Condenser
28.	1	649603	Bracket, Hardline Support

**** Before beginning installation, open all packages and check contents of shipment. Please report any shortages directly to Vintage Air within 15 days. After 15 days, Vintage Air will not be responsible for missing or damaged items.**

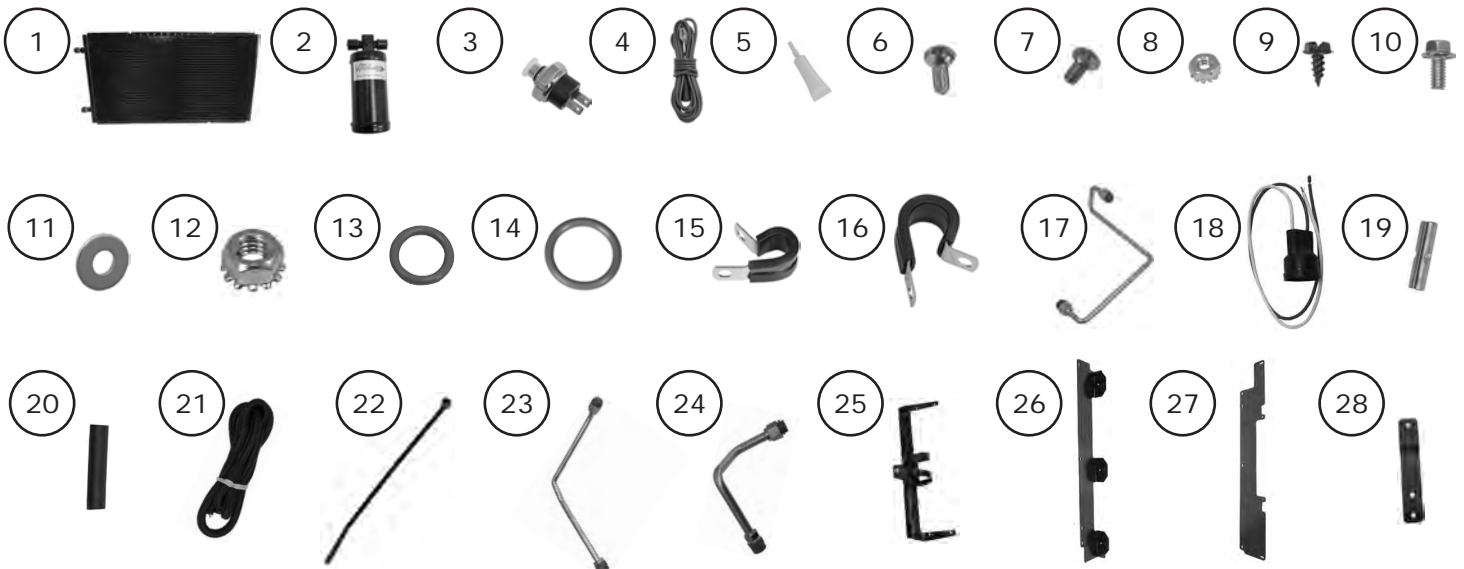

NOTE: Images may not depict actual parts and quantities. Refer to packing list for actual parts and quantities.



www.vintageair.com

Important Notice—Please Read

For Maximum System Performance, Vintage Air Recommends the Following:

NOTE: Vintage Air systems are designed to operate with R134a refrigerant only. Use of any other refrigerant could damage your A/C system and/or vehicle, and possibly cause a fire, in addition to potentially voiding the warranties of the A/C system and its components.

Refrigerant Capacities:

Vintage Air System: 1.8 lbs. (28.8 oz.) or 816 grams of **R134a**, charged by weight with a quality charging station or scale. **NOTE: Use of the proper type and amount of refrigerant is critical to system operation and performance.**

Other Systems: Consult manufacturer's guidelines.

Lubricant Capacities:

New Vintage Air-Supplied Sanden Compressor: No additional oil needed (Compressor is shipped with proper oil charge).

All Other Compressors: Consult manufacturer (Some compressors are shipped dry and will need oil added).

Safety Switches

Your Vintage Air system is equipped with a binary pressure safety switch. A binary switch disengages the compressor clutch in cases of extreme low pressure conditions (refrigerant loss) or excessively high head pressure (406 PSI) to prevent compressor damage or hose rupture. A trinary switch combines Hi/Lo pressure protection with an electric fan operation signal at 254 PSI, and should be substituted for use with electric fans. Compressor safety switches are extremely important since an A/C system relies on refrigerant to circulate lubricant.

Service Info:

Protect Your Investment: Prior to assembly, it is critical that the compressor, evaporator, A/C hoses and fittings, hardlines, condenser and receiver/drier remain capped. Removing caps prior to assembly will allow moisture, insects and debris into the components, possibly leading to reduced performance and/or premature failure of your A/C system. This is especially important with the receiver/drier.

Additionally, when caps are removed for assembly, **BE CAREFUL!** Some components are shipped under pressure with dry nitrogen.

Evacuate the System for 35-45 Minutes: Ensure that system components (Drier, compressor, evaporator and condenser) are at a temperature of at least 85°F. On a cool day, the components can be heated with a heat gun **or** by running the engine with the heater on before evacuating. Leak check and charge to specifications.

Bolts Passing Through Cowl and/or Firewall:

To ensure a watertight seal between the passenger compartment and the vehicle exterior, for all bolts passing through the cowl and/or firewall, Vintage Air recommends coating the threads with silicone prior to installation.

Heater Hose (not included with this kit):

Heater hose may be purchased from Vintage Air (Part#31800-VUD) or your local parts retailer. Routing and required length will vary based on installer preference.



www.vintageair.com

Core Support Measurements

This kit was developed based on the measurements below, which were taken from a 1984 Chevrolet Monte Carlo with factory air, 1982 Oldsmobile Cutlass with factory air, and a 1987 Buick Grand National with factory air.

Engine Side
of Core Support
View

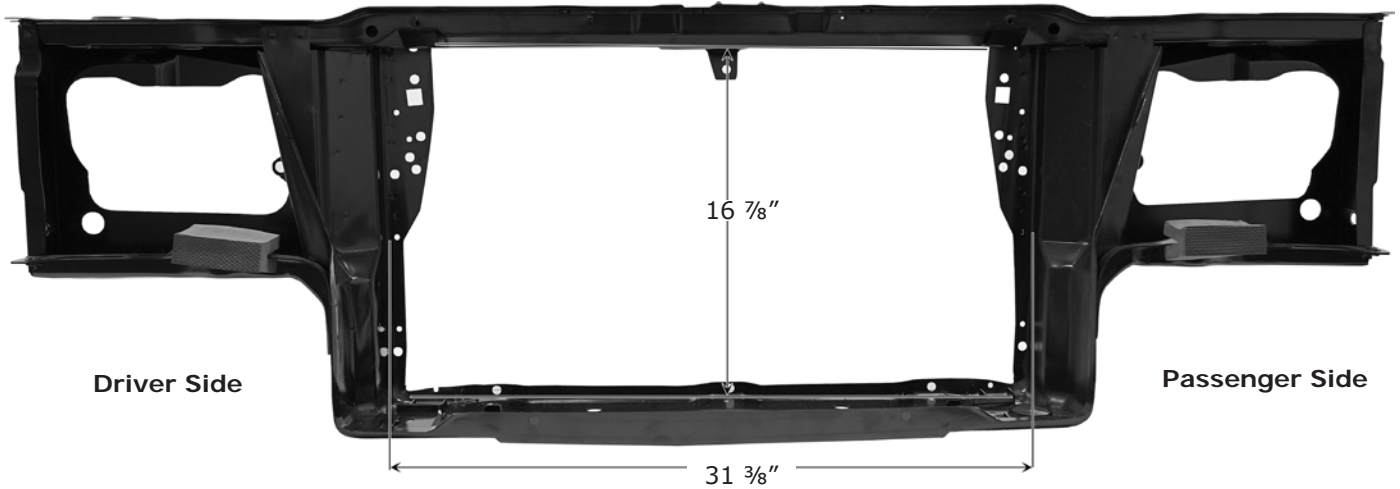

Engine Compartment Disassembly

NOTE: Before starting the installation, check the function of the vehicle (horn, lights, etc.) for proper operation, and study the instructions, illustrations, & diagrams.

Perform the Following:

1. Disconnect the battery.
2. Evacuate the A/C system if necessary.
3. Drain the radiator.
4. Remove the upper and lower radiator hoses.
5. Disconnect the A/C lines from the condenser (See Photo 1, below).
6. Remove the OEM fan by removing (4) cooling fan bolts (retain) (See Photo 2, below).
7. Remove the fan shroud by removing (5) fan shroud top bolts (See Photo 3, below) and (2) bottom bolts.

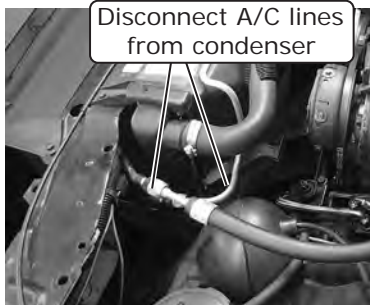

Photo 1

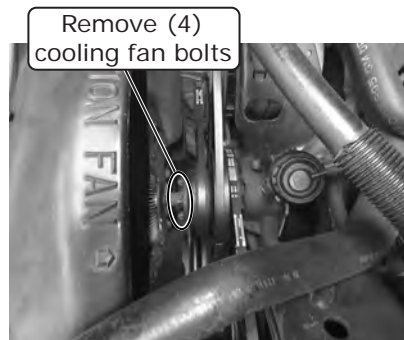

Photo 2



Photo 3



www.vintageair.com

Engine Compartment Disassembly (Cont.)

8. Automatic transmission: Disconnect the transmission lines from the radiator (See Photo 4, below).
9. Remove the radiator (retain) (See Photo 5, below).
10. Remove (2) upper condenser mounting bolts (retain hardware) (See Photos 6 and 7, below).
11. Remove the condenser assembly from the vehicle (discard).

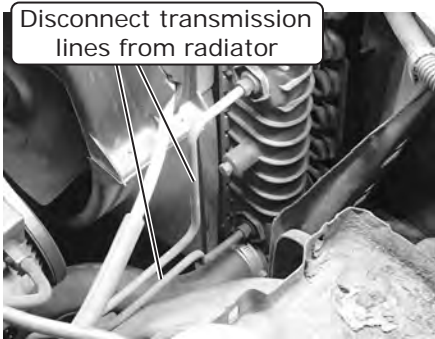

Photo 4



Photo 5

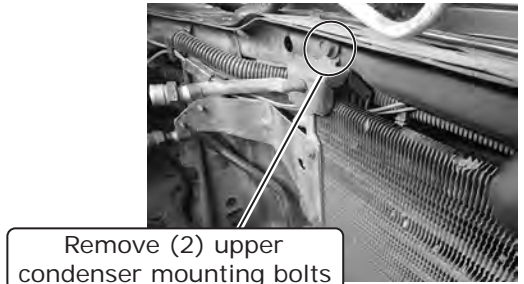

Photo 6



Photo 7

Core Support Modification

1. Position the lower condenser bracket into place on the lower core support as shown (See Photo 1, below).
2. Mark the (3) mounting holes, then remove the bracket (See Photo 2, below).
3. Using a 5/16" drill bit, drill the (3) mounting holes (See Photo 3, below).

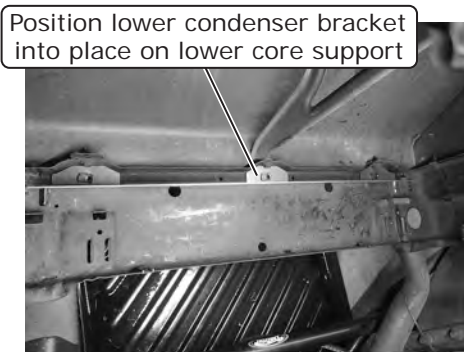
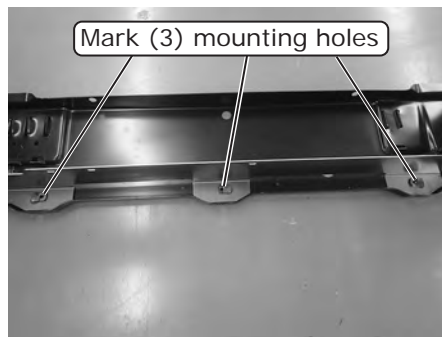
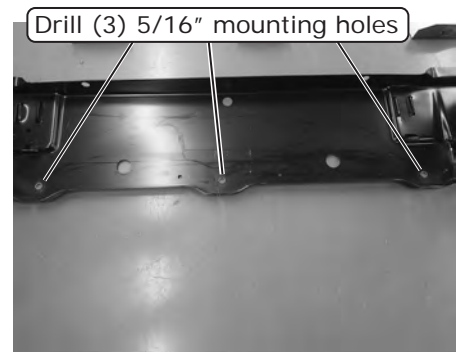

Photo 1



Front View

Photo 2



Front View

Photo 3



www.vintageair.com

Condenser Bracket Preparation and Installation (Stock Radiator)

NOTE: The condenser brackets are designed to work with stock radiators and many radiators with larger cores. The following steps show the installation for stock radiators. For radiators with larger cores, proceed to Page 8.

On a work bench, perform the following:

1. Position the upper condenser bracket over the upper condenser mounting rail (See Photo 1, below). Install the passenger-side condenser/drier bracket over the upper condenser bracket, aligning the mounting holes (See Photo 2, below). Secure them using (4) 10-24 x 3/8" pan head screws and (4) 10-24 nuts with star washers (See Photo 3, below).
2. Position the lower condenser bracket over the lower condenser mounting rail. Install the passenger-side condenser/drier bracket over the lower condenser bracket, aligning the mounting holes. Secure them using (4) 10-24 x 3/8" pan head screws and (4) 10-24 nuts with star washers (See Photo 4, below).

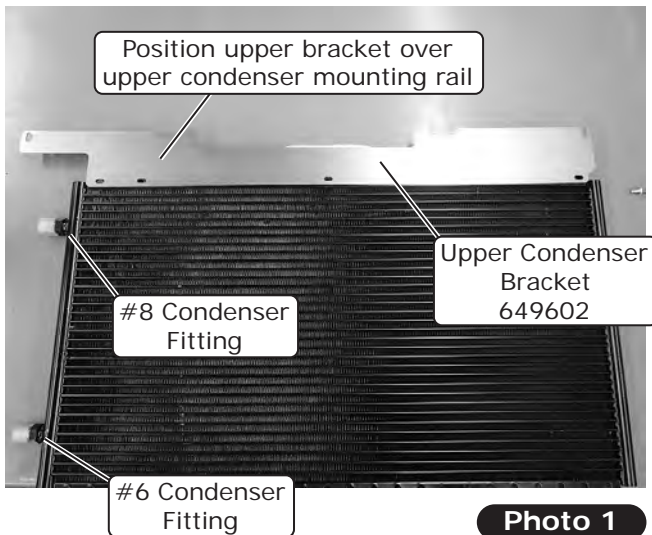

Photo 1

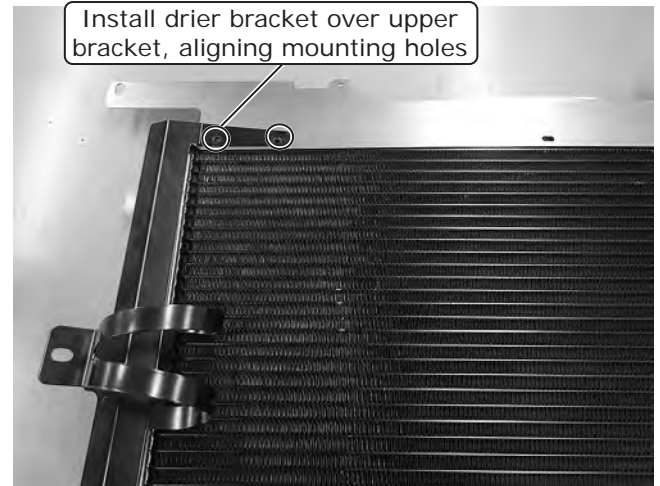

Photo 2



Photo 3

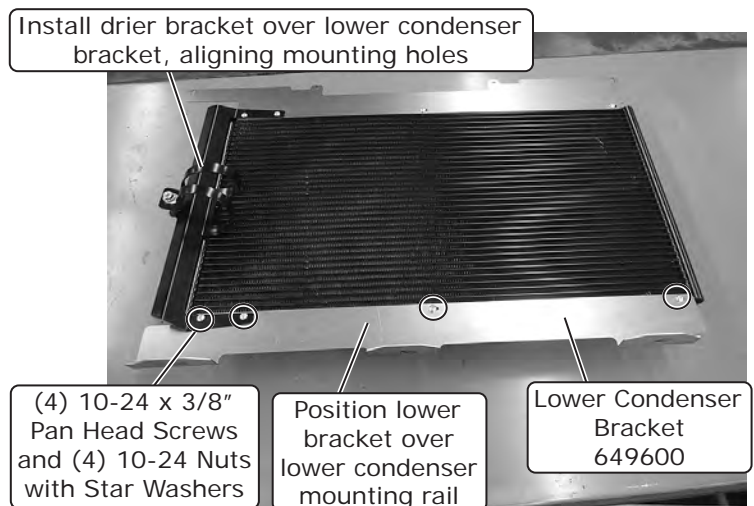

Photo 4



www.vintageair.com

Condenser Bracket Preparation and Installation (Larger Core Radiator)

NOTE: If using a radiator with a larger core, the mounting brackets can be installed on the rear of the condenser as shown below.

On a work bench, perform the following:

1. Position the upper condenser bracket over the upper condenser mounting rail, aligning the mounting holes (See Photo 1, below). Secure it using (4) 10-24 x 3/8" pan head screws and (4) 10-24 nuts with star washers (See Photo 1, below).
2. Position the lower condenser bracket over the lower condenser mounting rail, aligning the mounting holes. Secure it using (4) 10-24 x 3/8" pan head screws and (4) 10-24 nuts with star washers (See Photo 1, below).
3. Flip the condenser over and install the passenger-side condenser/drier bracket using (4) 10-24 x 3/8" pan head screws and (4) 10-24 nuts with star washers (See Photo 2, below).

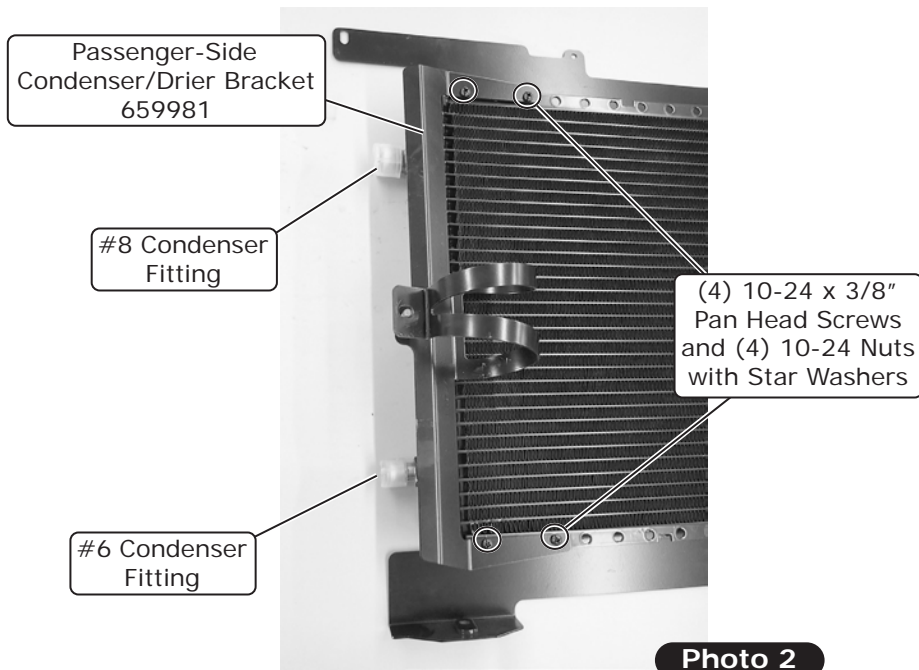
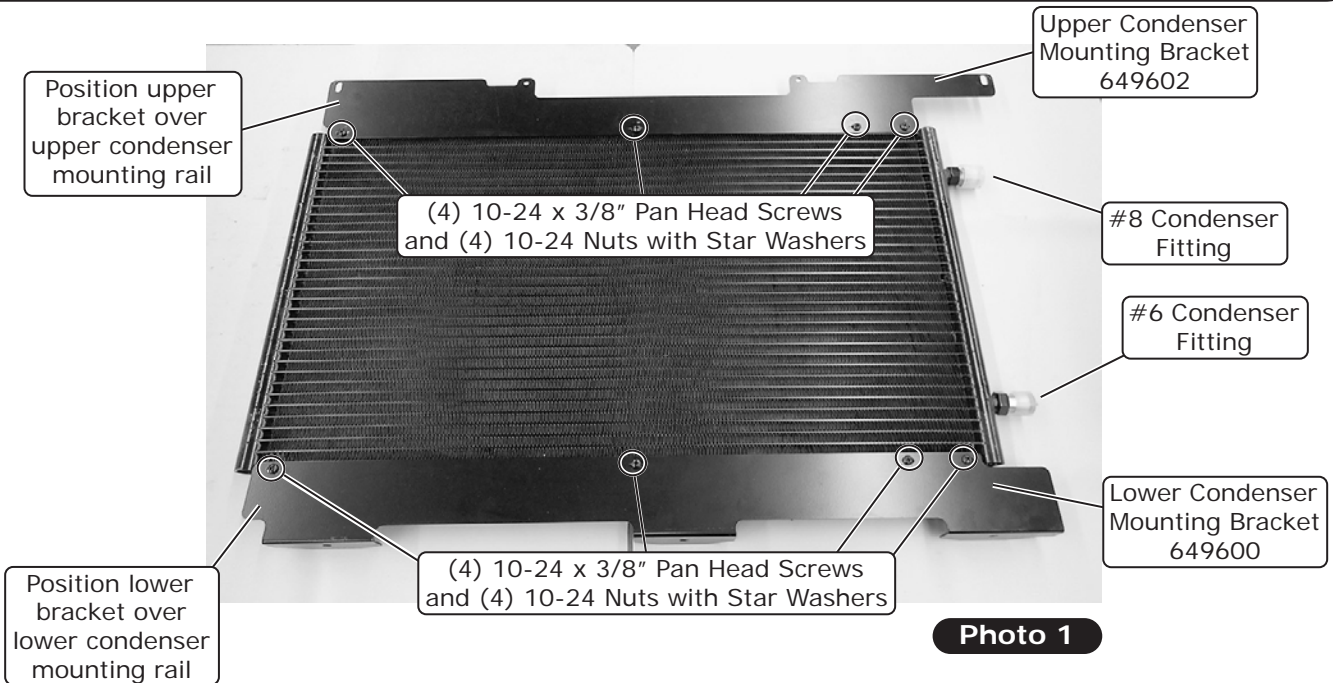



www.vintageair.com

Lubricating O-rings

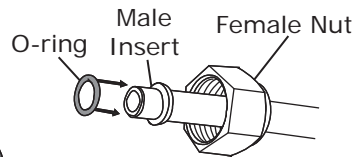
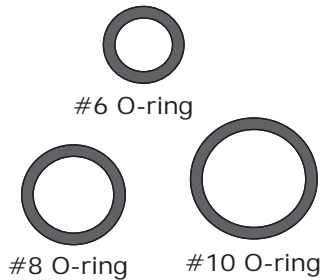

For a proper seal of fittings: Install supplied O-rings as shown and lubricate with supplied oil.

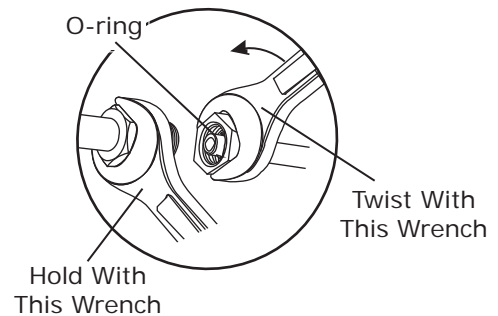
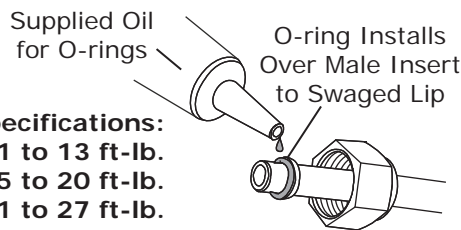

NOTE: Standard torque specifications:
 #6: 11 to 13 ft.-lb.
 #8: 15 to 20 ft.-lb.
 #10: 21 to 27 ft.-lb.

Drier, Hardline and Hardline Support Bracket Installation

NOTE: Do not remove the caps from the drier. The drier contains a desiccant that will quickly absorb moisture from the air, causing it to lose effectiveness. For this reason, Vintage Air recommends that the drier remains capped until the installer is ready to evacuate the system. The use of a backup wrench is important when installing the hardlines to avoid damage to the condenser (See Lubricating O-rings, above).

1. Insert the drier into the drier bracket (See Photo 1, below). Loosely secure the drier into the drier bracket using a 1/4-20 nut with star washer (See Photos 1 and 2, below). **NOTE: Do not fully tighten the nut at this time. Refrigerant flow through the drier is IN from condenser, OUT to evaporator.**
2. Lubricate (2) #6 O-rings (See Lubricating O-rings, above). Install the #6 drier/condenser hardline onto the drier and the #6 fitting on the condenser (See Photo 3, below). Tighten the fittings as shown in Lubricating O-rings, above. **NOTE: Tighten the drier bracket nut at this time.**
3. With a properly lubricated #8 O-ring, loosely install the #8 condenser/compressor hardline onto the #8 fitting on the condenser (See Photo 4, below).

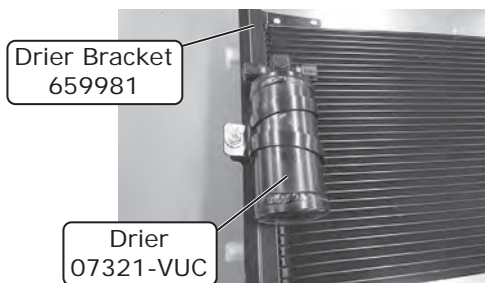

Photo 1

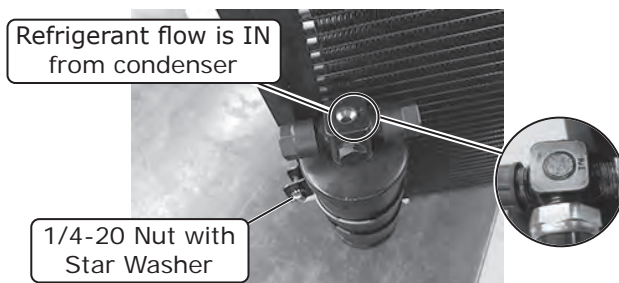

Photo 2

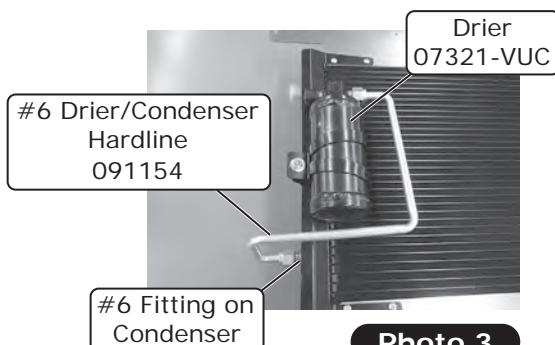

Photo 3

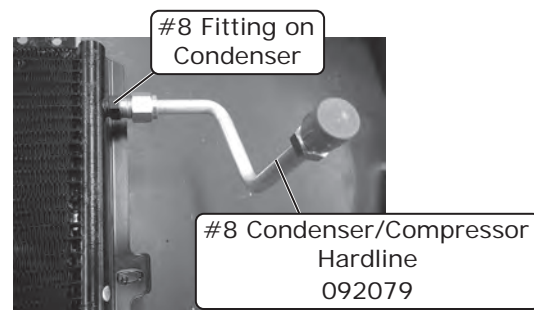

Photo 4



www.vintageair.com

Drier, Hardline and Hardline Support Bracket Installation (Cont.)

4. With a properly lubricated #6 O-ring (See Lubricating O-rings, Page 8), loosely install the #6 drier/evaporator hardline onto the drier (See Photos 5 and 6, below). Install the 3/8" I.D. and 1/2" I.D. Adel clamps onto the #6 and #8 hardlines (See Photo 7, below).
5. Using a 10-24 x 1/2" screw and a 10-24 nut with star washer, loosely secure the Adel clamps to the hardline support bracket (See Photo 8, below).
6. Lower the condenser assembly into the core support, then adjust the hardlines and support bracket. Once adjusted, tighten the #8 hardline (See Photo 9, below).
7. Using the hardline support bracket as a template, mark the (2) mounting holes onto the core support, then remove the condenser assembly (See Photo 9, below).
8. Tighten the #6 hardline connection at the drier and the Adel clamp hardware (See Photos 10 and 11, below).
9. Using a 9/64" drillbit, drill the (2) mounting holes into the core support (See Photo 12, below).



Photo 5

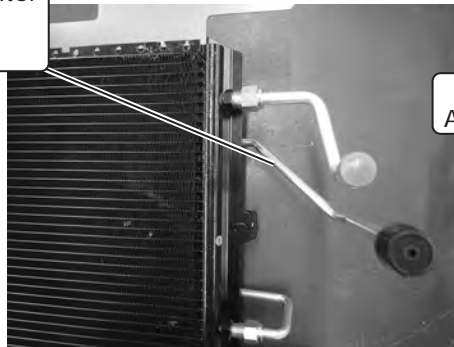

Photo 6

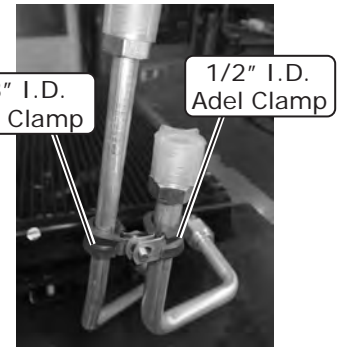

Photo 7



Photo 8

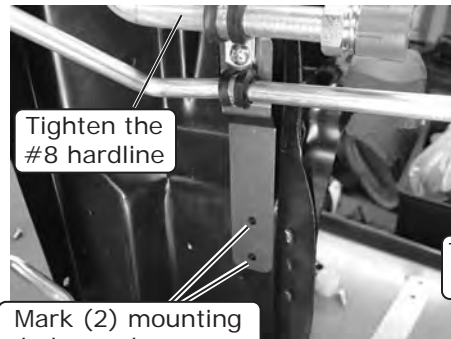

Photo 9

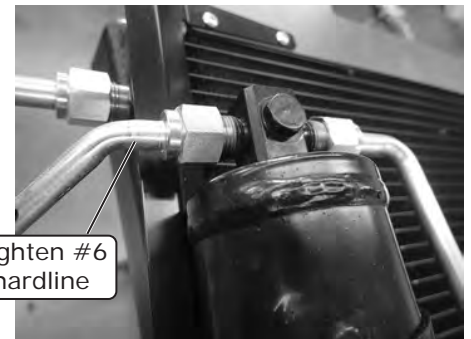

Photo 10

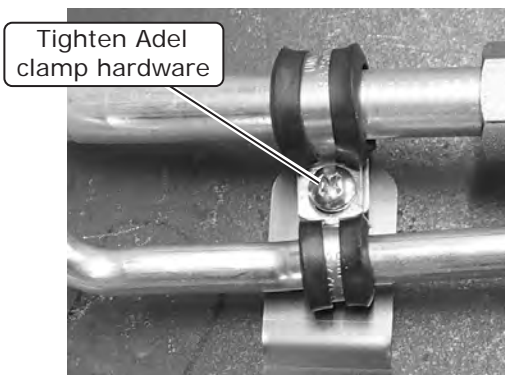

Photo 11



Photo 12



www.vintageair.com

Binary Switch Installation

1. Lubricate the binary switch O-ring (See Lubricating O-rings, Page 9), and install it onto the drier (See Photos 1 and 2, below). **NOTE: The binary switch and the drier each come with an O-ring. Only use the binary switch O-ring.**
2. Install the binary switch boot (See Photo 3, below).
3. Wrap the wiring with the supplied flexo-sleeve and secure the wires to the #6 hardline using tie wraps (See Photo 4, below).

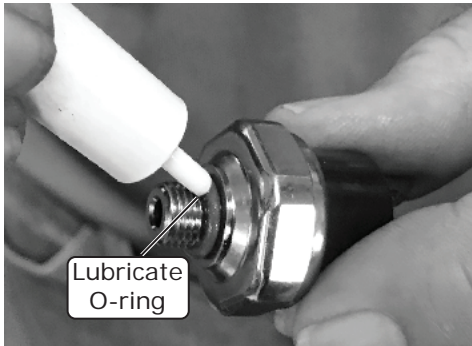

Photo 1

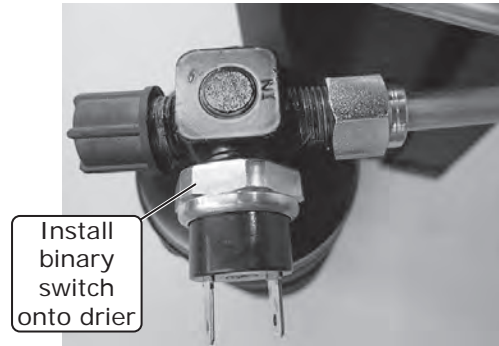

Photo 2



Photo 3



Photo 4



www.vintageair.com

Condenser Installation

1. Lower the condenser assembly into the core support and loosely install the (2) OEM upper mounting bolts (See Photos 1 and 2, below).
2. Install (3) 1/4-20 x 1/2" flange hex bolts into the lower condenser assembly bracket through the previously drilled holes on the core support, then tighten (See Photos 3, 4, and 5, below).
3. Tighten the upper OEM hardware at this time.
4. Using the upper condenser bracket as a template, drill (2) mounting holes using a 9/64" drillbit, then install (2) #10 x 1/2" sheet metal screws for added support (See Photo 6, below).
5. Secure the hardline support bracket into the previously drilled holes using (2) #10 x 1/2" sheet metal screws (See Photo 7, below).

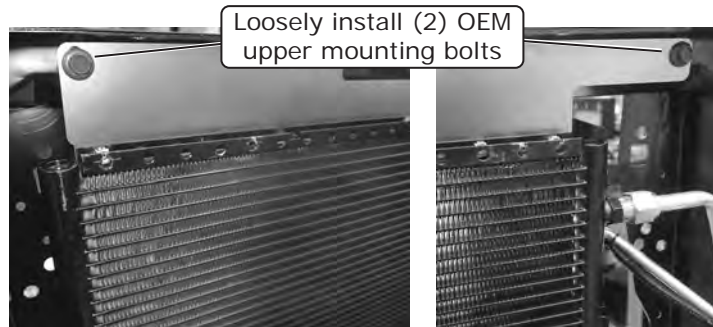

Photo 1

Photo 2

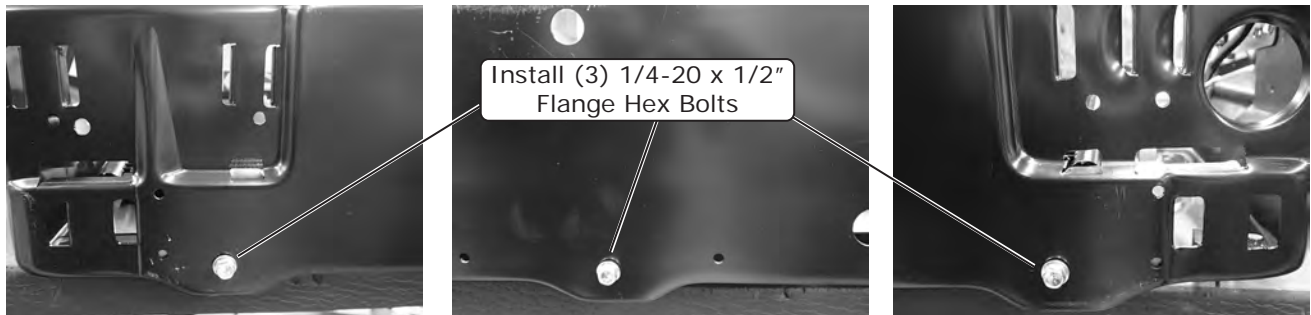

Photo 3

Photo 4

Photo 5

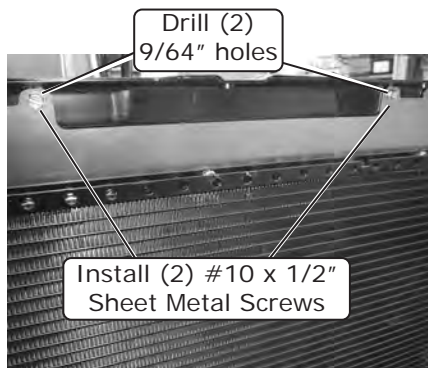

Photo 6

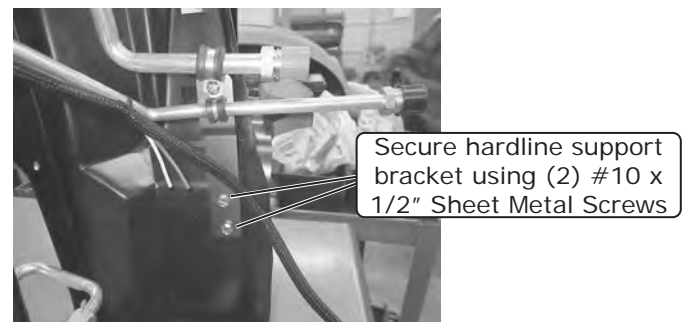

Photo 7



www.vintageair.com

Condenser Installation (Cont.)

Pasenger-Side

Driver-Side

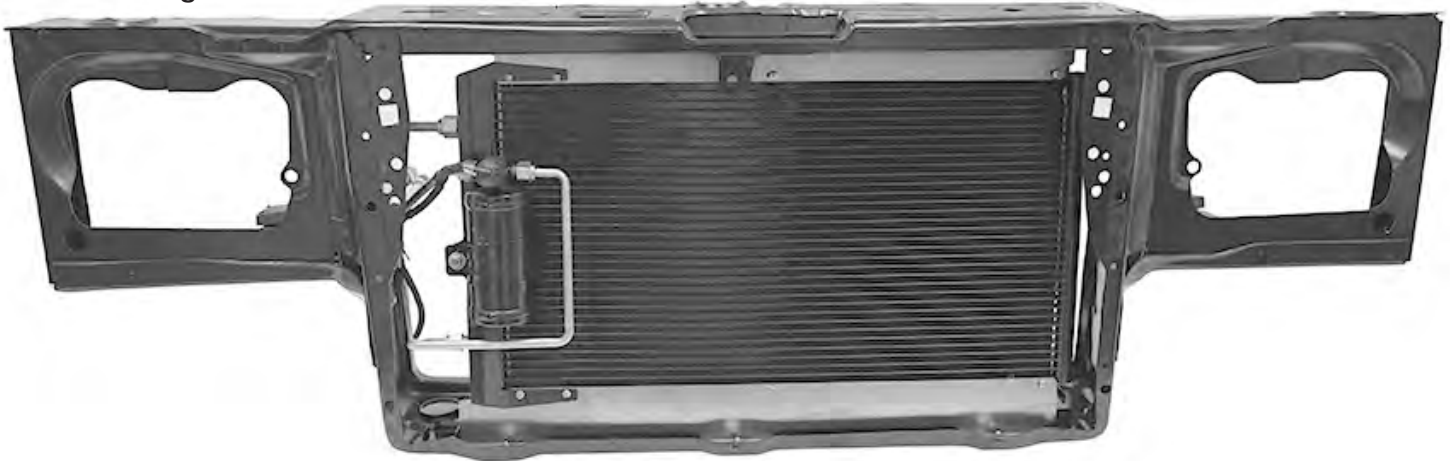

Final Installation
(Stock Radiator)

(Front View)

Driver-Side

Pasenger-Side

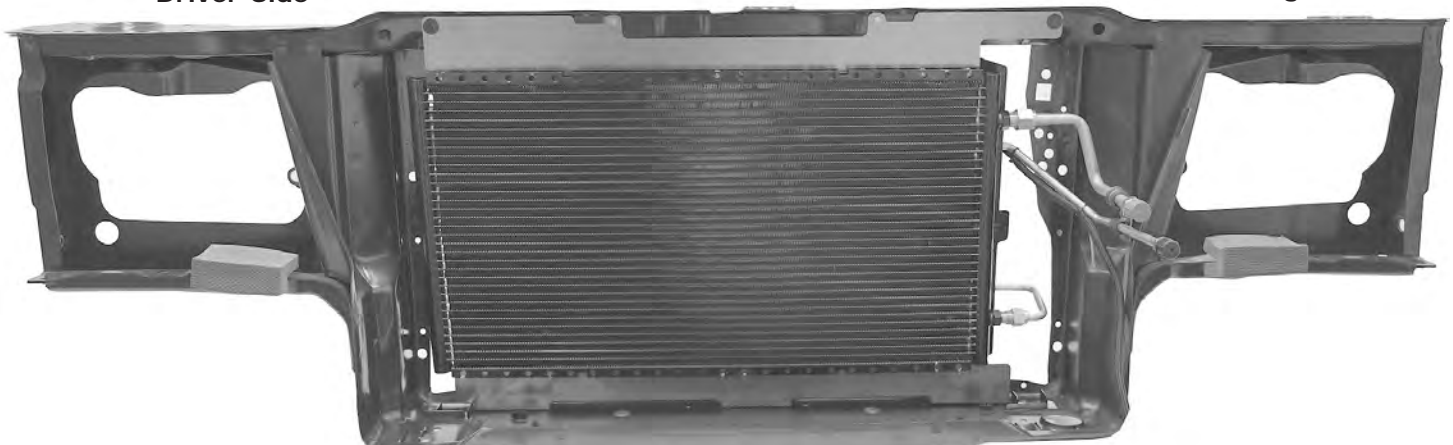

Final Installation
(Stock Radiator)

(Engine View)

Final Steps

NOTE: A butt splice and heat shrink are included to connect the compressor lead and the main wiring harness to the binary switch boot.

1. Reinstall and/or reconnect all remaining items removed or disconnected in the engine compartment disassembly instructions. This concludes the condenser kit portion of your installation. **NOTE:** If proceeding to the evaporator installation portion of the install, do not reinstall and/or reconnect all items removed or disconnected.



www.vintageair.com

Packing List: Condenser Kit (025082)

No.	Qty.	Part No.	Description
1.	1	03771-VUC	Condenser, 25 1/2" x 14", Parallel Flow
2.	1	07321-VUC	Drier
3.	1	11079-VUS	Binary Switch, Male
4.	1	23135-VUW	Compressor Lead
5.	1	41117-VUP	Refrigerant Oil
6.	1	182479	Screw, 10-24 x 1/2", Pan Head
7.	12	18249-VUB	Screw, 10-24 x 3/8", Pan Head
8.	13	18260-VUB	Nut with Star Washer, 10-24
9.	4	18247-VUB	Screw, #10 x 1/2", Sheet Metal
10.	3	182870	Bolt, 1/4-20 x 1/2", Flange Hex
11.	1	18125-VUB	Washer, 5/16"
12.	1	18152-VUB	Nut with Star Washer, 1/4-20
13.	4	33857-VUF	O-ring, #6
14.	2	33858-VUF	O-ring, #8
15.	1	31600-VUD	Adel Clamp, 3/8" I.D.
16.	1	31603-VUD	Adel Clamp, 1/2" I.D.
17.	1	091154	Hardline, #6 Drier/Condenser
18.	1	110790	Boot, Binary Switch
19.	2	226004	Butt Splice, 22-16 AWG
20.	2	226012	Heat Shrink, 1/4"
21.	48"	238013	Flexo Sleeve, 1/4"
22.	3	21301-VUP	Tie Wrap, 4"
23.	1	092078	Hardline, #6 Drier/Evaporator
24.	1	092079	Hardline, #8 Condenser/Compressor
25.	1	659981	Bracket, Condenser/Drier, Passenger-Side
26.	1	649600	Bracket, Lower Condenser
27.	1	649602	Bracket, Upper Condenser
28.	1	649603	Bracket, Hardline Support

Checked By: _____
 Packed By: _____
 Date: _____

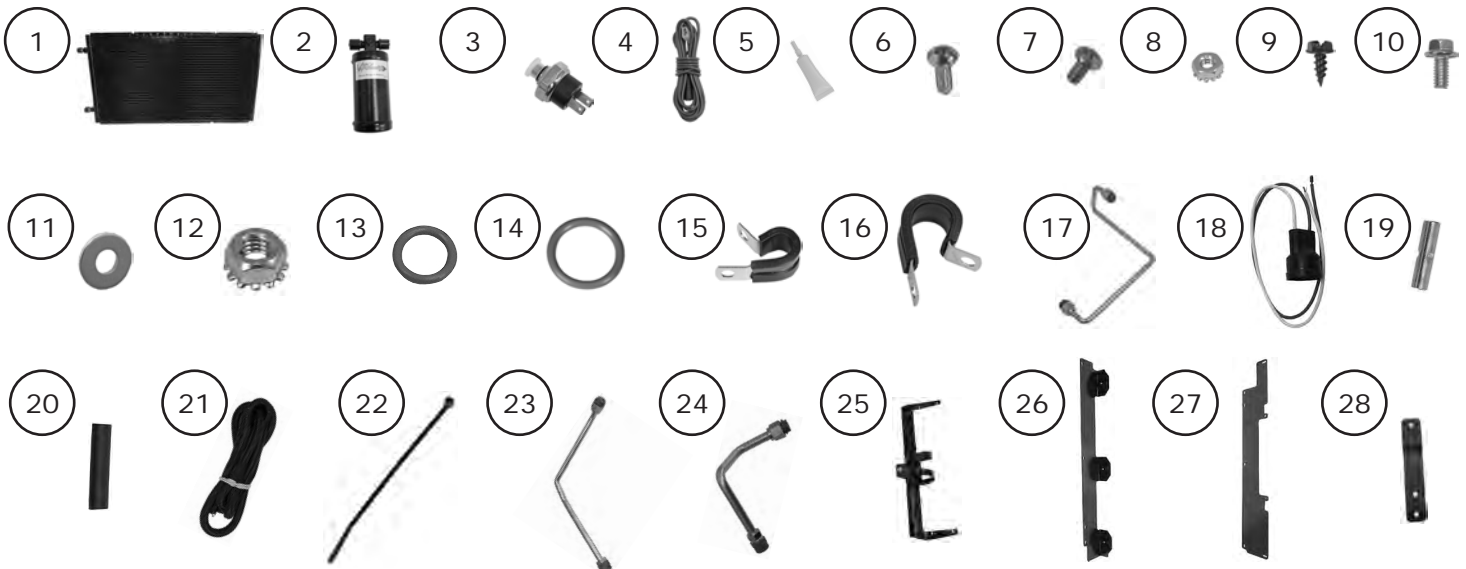

**NOTE: Images may not depict actual parts and quantities.
 Refer to packing list for actual parts and quantities.**