



1970-81 Pontiac Firebird

with Factory Air
Gen 5 Evaporator Kit
(564415)



18865 Goll St. San Antonio, TX 78266
Phone: 800-862-6658
Sales: sales@vintageair.com
Tech Support: tech@vintageair.com
www.vintageair.com



www.vintageair.com

Table of Contents

| | |
|---|-------|
| Cover..... | 1 |
| Table of Contents..... | 2 |
| Packing List/Parts Disclaimer..... | 3 |
| Information Page..... | 4 |
| Wiring Notice..... | 5 |
| Engine Compartment Disassembly..... | 6 |
| Engine Compartment Disassembly (Cont.), Condenser Assembly and Installation, Compressor and Brackets..... | 7 |
| OEM Control Panel Removal..... | 8-9 |
| Passenger Compartment Disassembly..... | 10 |
| Firewall Modification, Firewall Cover Installation and Insulation..... | 11 |
| Firewall Modification, Firewall Cover Installation and Insulation (Cont.), Defrost Duct Installation.. | 12 |
| Hose Adapter Installation..... | 13 |
| Passenger-Side Kick Panel & Fresh Air Cover Modification..... | 14 |
| Passenger-Side Kick Panel & Fresh Air Cover Modification (Cont.)..... | 15 |
| Lubricating O-rings, Properly Seated O-ring Land..... | 16 |
| Evaporator Preparation..... | 17-18 |
| Wiring Installation..... | 19 |
| Kick Panel Cover Installation, Fresh Air Cap Installation..... | 20 |
| Evaporator Installation..... | 21 |
| Drain Hose Installation, Under Dash Hose Adapter Assembly Installation..... | 22 |
| Driver-Side Under Dash Cover Installation..... | 23 |
| Duct Hose Routing..... | 24 |
| Heater Hose & Heater Control Valve Installation, A/C and Heater Hose Routing..... | 25 |
| Engine Compartment Wiring..... | 26 |
| Final Steps: Installation Check..... | 27 |
| Final Steps: Completing the Install, Glove Box Installation..... | 28 |
| Quality Crimp Guideline..... | 29 |
| Gen 5 Wiring Diagram..... | 30 |
| Gen 5 Wiring Connection Instruction..... | 31 |
| Operation of Controls..... | 32 |
| Troubleshooting Guide..... | 33 |
| Troubleshooting Guide (Cont.), Advanced Diagnostics and Troubleshooting Guide..... | 34 |
| Packing List..... | 35 |



www.vintageair.com

Packing List: Evaporator Kit (564415)

| No. | Qty. | Part No. | Description |
|-----|------|----------|--------------------------------------|
| 1. | 1 | 765200 | Gen 5 Magnum Max Module with 404 ECU |
| 2. | 1 | 784415 | Accessory Kit |

**** Before beginning installation, open all packages and check contents of shipment. Please report any shortages directly to Vintage Air within 15 days. After 15 days, Vintage Air will not be responsible for missing or damaged items.**

1



Gen 5 Magnum Max
Module with 404 ECU
765200

2

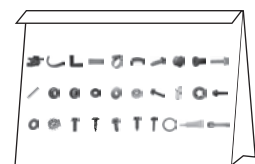
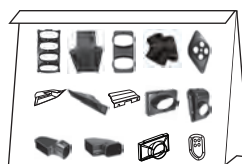
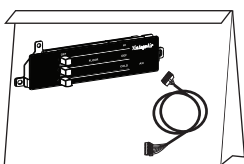
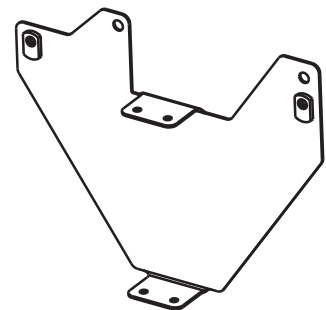
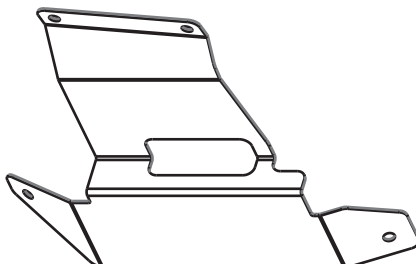
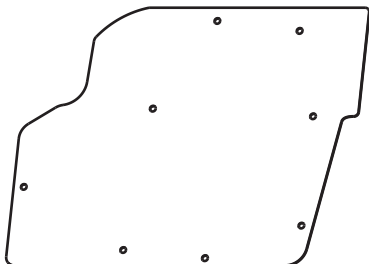

Accessory Kit
784415

NOTE: Images may not depict actual parts and quantities. Refer to packing list for actual parts and quantities.



www.vintageair.com

Important Notice—Please Read

For Maximum System Performance, Vintage Air Recommends the Following:

NOTE: Vintage Air systems are designed to operate with R134a refrigerant only. Use of any other refrigerant could damage your A/C system and/or vehicle, and possibly cause a fire, in addition to potentially voiding the warranties of the A/C system and its components.

Refrigerant Capacities:

Vintage Air System: 1.8 lbs. (28.8 oz.) or 816 grams of **R134a**, charged by weight with a quality charging station or scale. **NOTE: Use of the proper type and amount of refrigerant is critical to system operation and performance.**

Other Systems: Consult manufacturer's guidelines.

Lubricant Capacities:

New Vintage Air-Supplied Sanden Compressor: No additional oil needed (Compressor is shipped with proper oil charge).

All Other Compressors: Consult manufacturer (Some compressors are shipped dry and will need oil added).

Safety Switches

Your Vintage Air system is equipped with a binary pressure safety switch. A binary switch disengages the compressor clutch in cases of extreme low pressure conditions (refrigerant loss) or excessively high head pressure (406 PSI) to prevent compressor damage or hose rupture. A trinary switch combines Hi/Lo pressure protection with an electric fan operation signal at 254 PSI, and should be substituted for use with electric fans. Compressor safety switches are extremely important since an A/C system relies on refrigerant to circulate lubricant.

Service Info:

Protect Your Investment: Prior to assembly, it is critical that the compressor, evaporator, A/C hoses and fittings, hardlines, condenser and receiver/drier remain capped. Removing caps prior to assembly will allow moisture, insects and debris into the components, possibly leading to reduced performance and/or premature failure of your A/C system. This is especially important with the receiver/drier.

Additionally, when caps are removed for assembly, **BE CAREFUL!** Some components are shipped under pressure with dry nitrogen.

Evacuate the System for 35-45 Minutes: Ensure that system components (Drier, compressor, evaporator and condenser) are at a temperature of at least 85°F. On a cool day, the components can be heated with a heat gun **or** by running the engine with the heater on before evacuating. Leak check and charge to specifications.

Bolts Passing Through Cowl and/or Firewall:

To ensure a watertight seal between the passenger compartment and the vehicle exterior, for all bolts passing through the cowl and/or firewall, Vintage Air recommends coating the threads with silicone prior to installation.

Heater Hose (not included with this kit):

Heater hose may be purchased from Vintage Air (Part#31800-VUD) or your local parts retailer. Routing and required length will vary based on installer preference.



www.vintageair.com

Important Wiring Notice—Please Read

Some vehicles may have had some or all of their radio interference capacitors removed. There should be a capacitor found at each of the following locations:

- 1. On the positive terminal of the ignition coil.**
- 2. If there is a generator, on the armature terminal of the generator.**
- 3. If there is a generator, on the battery terminal of the voltage regulator.**

Most alternators have a capacitor installed internally to eliminate what is called “whining” as the engine is revved. If whining is heard in the radio, or just to be extra cautious, a radio interference capacitor can be added to the battery terminal of the alternator.

It is also important that the battery lead is in good shape and that the ground leads are not compromised. There should be a heavy ground from the battery to the engine block, and additional grounds to the body and chassis.

If these precautions are not observed, it is possible for voltage spikes to be present on the battery leads. These spikes come from ignition systems and charging systems, and from switching some of the vehicle’s other systems on and off. Modern computer-operated equipment can be sensitive to voltage spikes on the power leads, which can cause unexpected resets, strange behavior and/or permanent damage.

Vintage Air strives to harden our products against these types of electrical noise, but there is a point where a vehicle’s electrical system can be degraded so much that nothing can help.

Radio interference capacitors should be available at most auto and truck parts suppliers. They typically are cylindrical in shape, a little over an inch long and a little over a half-inch in diameter, and they have a single lead coming from one end of the cylinder with a terminal on the end of the wire, as well as a mounting clip which is screwed into a good ground on the vehicle. The specific value of the capacitance is not too significant in comparison to ignition capacitors that are matched with the coil to reduce pitting of the points.

- Care must be taken, when installing the compressor lead, not to short it to ground. The compressor lead must not be connected to a condenser fan or to any other auxiliary device. Shorting to ground or connecting to a condenser fan or any other auxiliary device may damage wiring or the compressor relay, and/or cause a malfunction.
- When installing ground leads on Gen 5 systems, the blower control ground and ECU ground must be connected directly to the negative battery post.
- For proper system operation, the heater control valve must be connected to the ECU.



www.vintageair.com

Engine Compartment Disassembly

NOTE: Before starting the installation, check the function of the vehicle (horn, lights, etc.) for proper operation, and study the instructions, illustrations, photos & diagrams. Retain OEM bolts, screws, washers and nuts, as some hardware will be reused.

Perform the following:

1. Remove the hood and the passenger-side hood hinge. **NOTE: Make a mark around the hood hinge to show where it is located.**
2. Place (2) jack stands under the sway bar below the frame to keep the complete frame straight (See Photo 1, below).
3. Disconnect the battery.
4. Drain the radiator.
5. Evacuate the A/C system, and loosen the expansion valve nut to drain the refrigerant oil (See Photos 2 & 3, below). **NOTE: Refrigerant oil may be under pressure. Be careful when loosening the expansion valve nut, and place a rag around the fitting to absorb the oil.**
6. Remove the expansion valve nut (discard) (See Photo 3, below).
7. Remove the A/C and heater hoses, lines and A/C muffler (discard) (See Photo 4, below).
8. Remove the air cleaner (retain) (See Photo 4, below).
9. Remove the OEM compressor and brackets (discard) (See Photo 4, below).
10. Remove the passenger-side front tire (retain).

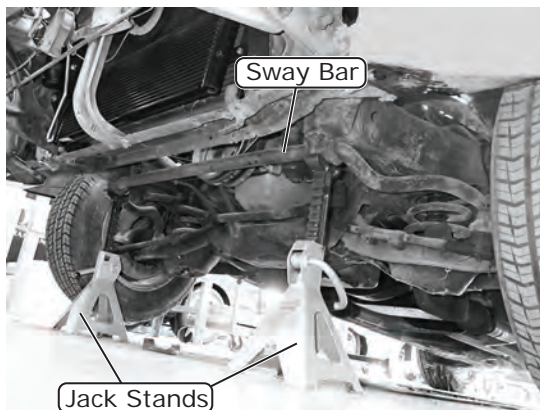

Photo 1

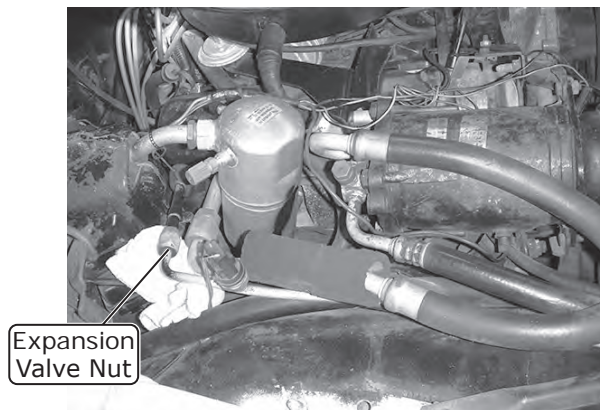

Photo 2

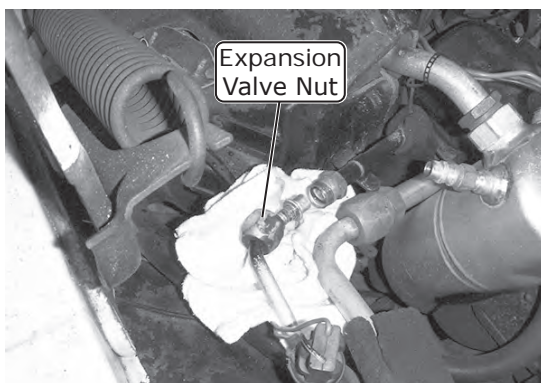

Photo 3

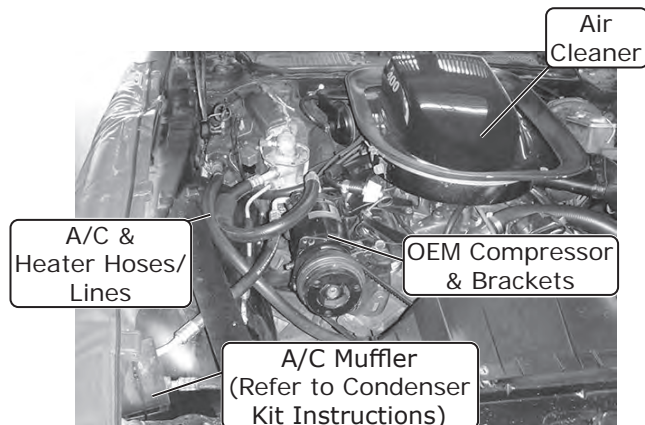

Photo 4



www.vintageair.com

Engine Compartment Disassembly (Cont.)

11. Remove the passenger-side inner fender and radiator overflow (retain) (See Photo 6, below). To remove the inner fender, remove the passenger-side lower fender bolts (See Photo 5, below). **NOTE: Protect the fender and door to avoid scratching the paint.**
12. Remove the OEM A/C and heater wiring (discard) (See Photo 7, below).
13. Remove the OEM evaporator with blower motor (discard) (See Photo 7, below).

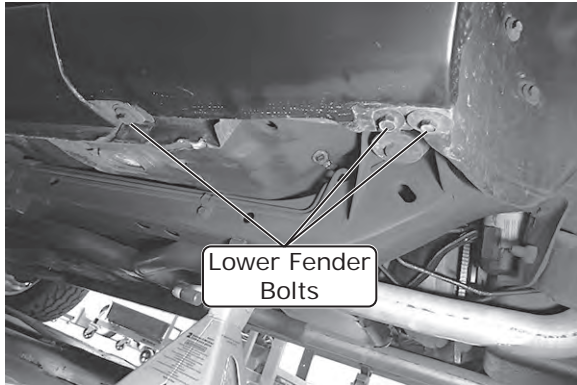

Photo 5



Photo 6

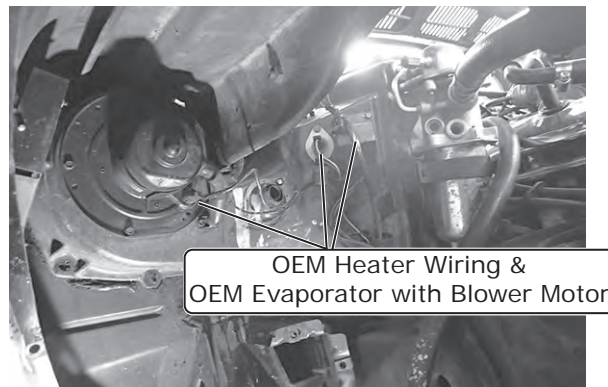

Photo 7

Condenser Assembly and Installation

1. Refer to separate instructions included with the condenser kit to install the condenser.
2. Binary switch installation (Refer to condenser instructions).

Compressor and Brackets

1. Refer to separate instructions included with the bracket kit to install the compressor bracket.



www.vintageair.com

OEM Control Panel Removal

Perform the following:

1. Remove the (2) screws retaining the plastic cover beneath the steering column as shown in Photo 1, below (retain). Remove the cover (retain).
2. Remove the instrument panel trim plate by removing (2) lower screws (See Photo 2, below), (3) upper screws (See Photo 3, below), and the lighter retainer nut ring (See Photos 4 and 5, below) (retain).

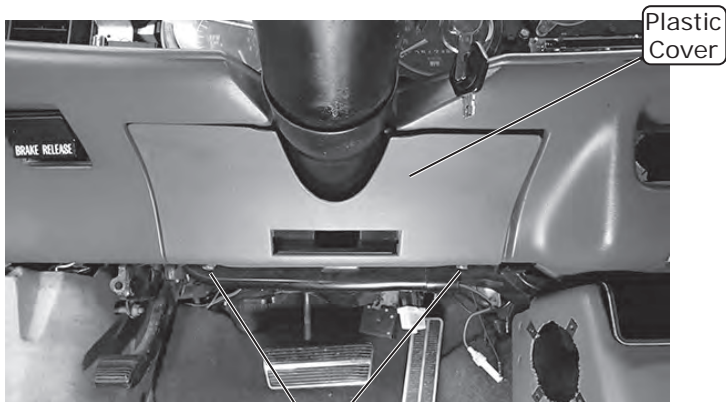

Remove
(2) screws

Photo 1

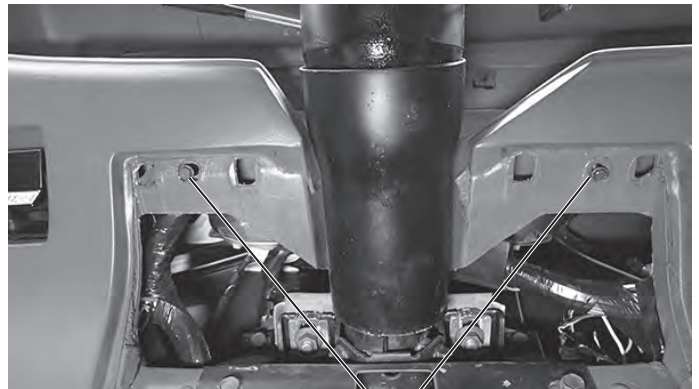

Remove
(2) screws

Photo 2



Remove
(3) screws

Instrument
Panel Trim Plate

Photo 3

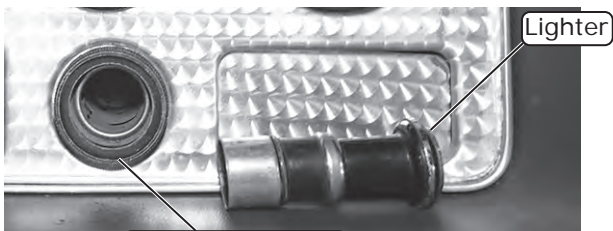

Lighter
Retainer Nut Ring

Photo 4

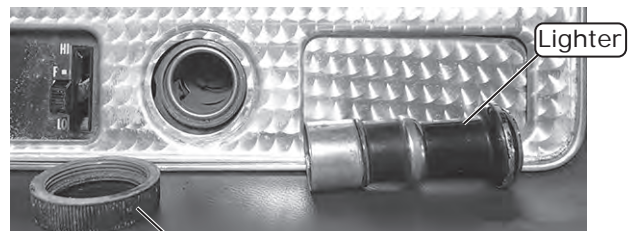

Lighter
Retainer Nut Ring

Photo 5



www.vintageair.com

OEM Control Panel Removal (Cont.)

3. Disconnect the cables and wires from the back of the control panel as shown in Photo 7, below. **NOTE:** For ease of access to the control panel cables and wires, Vintage Air recommends removing the gauge cluster located directly above the control panel (See Photo 6, below).
4. Remove the OEM control panel (discard).

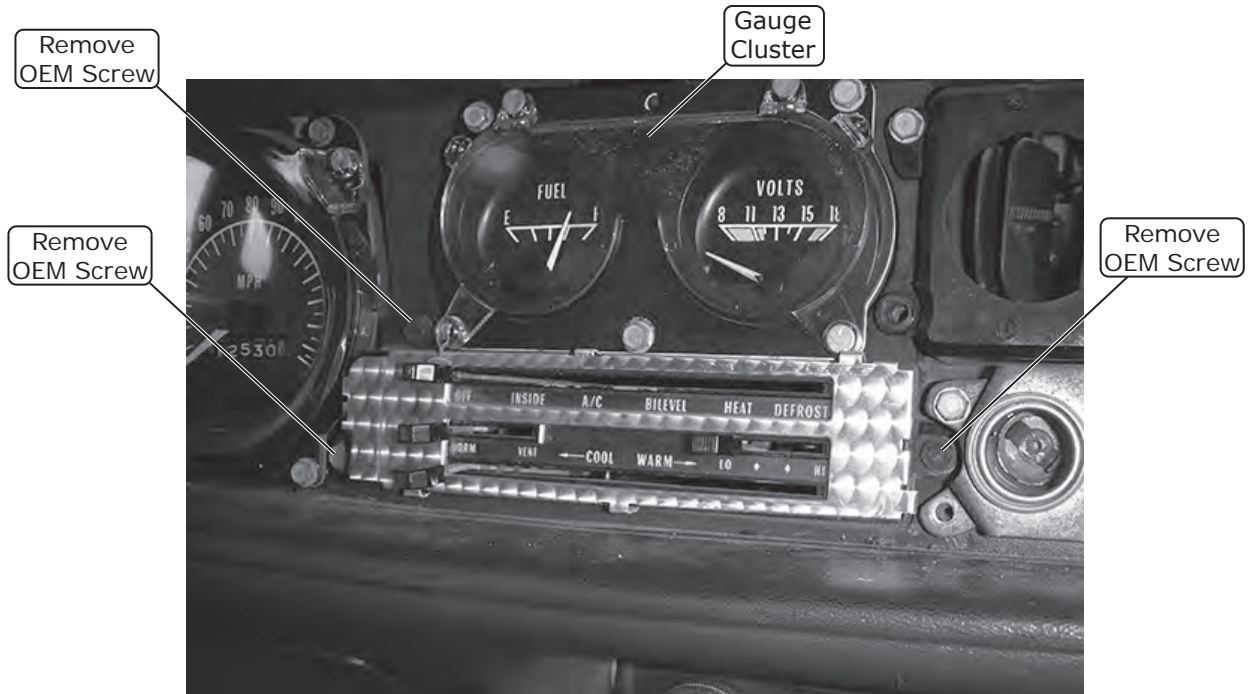

Photo 6

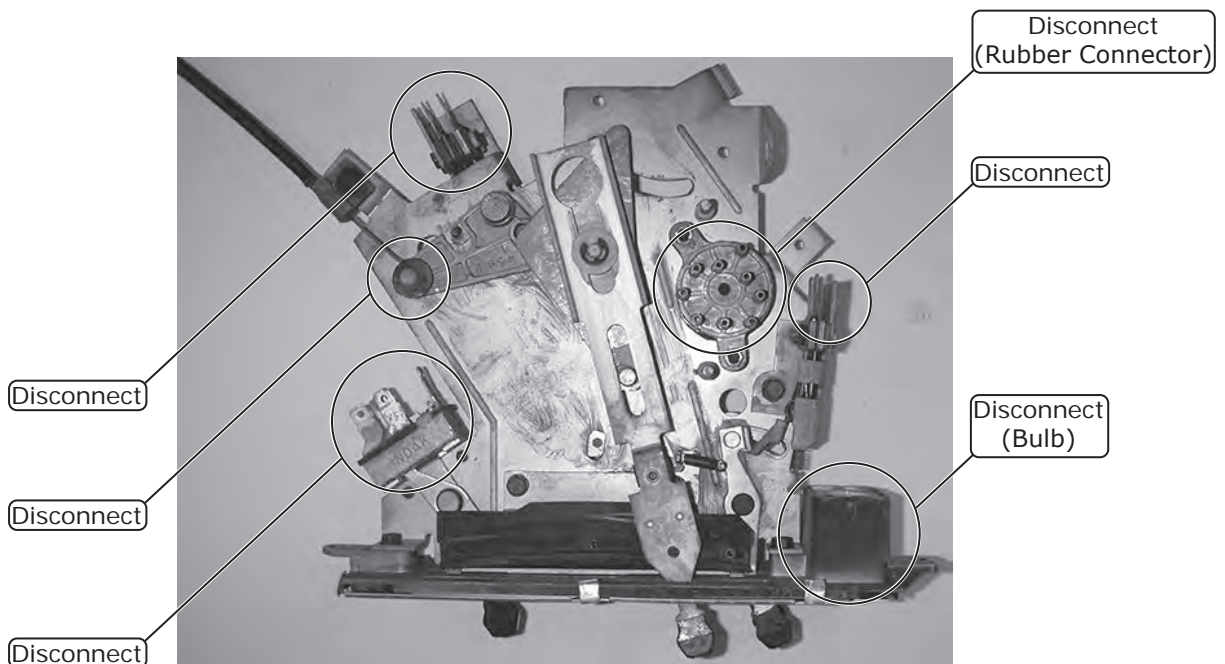

Photo 7



www.vintageair.com

Passenger Compartment Disassembly

Perform the following:

1. For ease of access in the passenger compartment, remove the passenger seat.
2. Remove the glove box door (retain) (See Figure 1, below).
3. Remove the glove box (discard) (See Figure 1, below).
4. Remove the passenger-side kick panel fresh air cover (retain), door vacuum (discard) and passenger-side kick panel (retain) (See Figure 3, below).
5. Remove the OEM heater assembly (discard) (See Figure 2, below).
6. Remove all heater assembly ducting (discard).
7. Remove the (2) wires and grommets located on the firewall by the heater/evaporator assembly opening (discard).
8. Remove the OEM defrost ducts (discard) (See Figure 2, below).

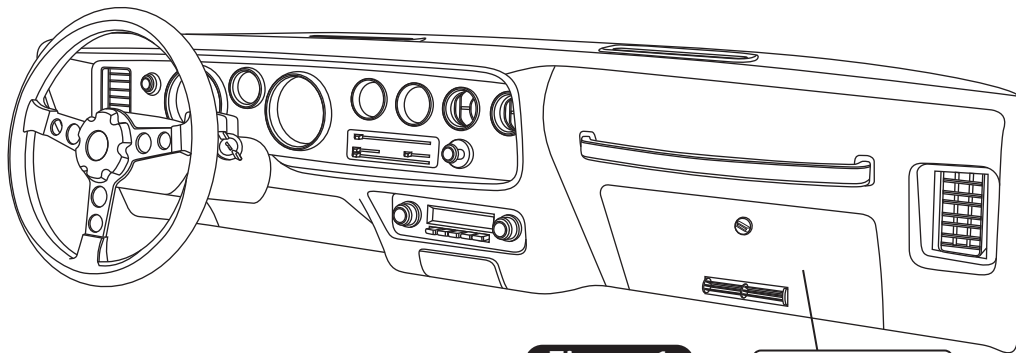

Figure 1

Glove Box Door
& Glove Box

Defrost
Ducts

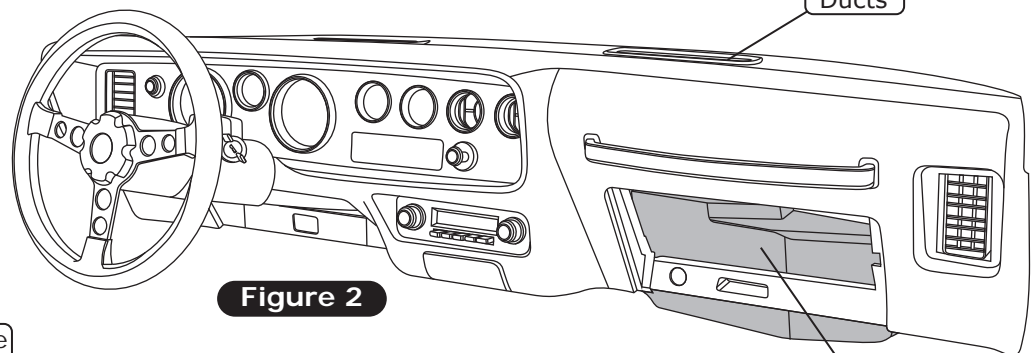

Figure 2

OEM Heater Assembly
& Ducting

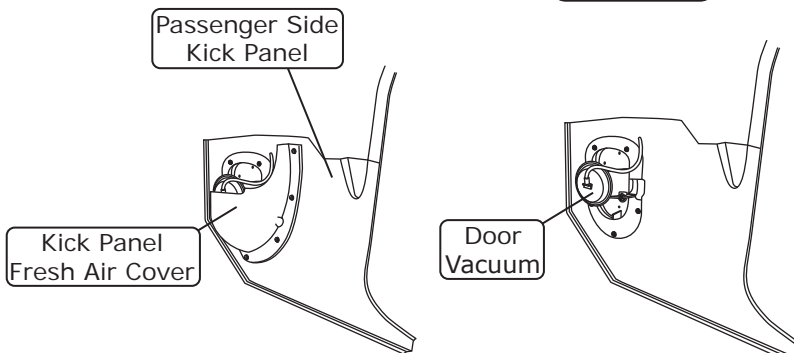

Figure 3



www.vintageair.com

Firewall Modification, Firewall Cover Installation and Insulation

NOTE: Firewall modification is required for firewall cover and drain hose installation.

1. Flatten the edges of the firewall opening (See Photos 1 and 2, below). **NOTE: For proper system operation, Vintage Air recommends using Dynaliner (461500-VIP) heatblocking insulation in the area around the evaporator module (firewall, kick panel, inner cowl and firewall covers). Due to tight clearance for the evaporator module, between the firewall and dash, Vintage Air recommends an insulation thickness of no more than 1/8".**
2. Install (4) 1/4-20 x 3/4" serrated flange black bolts, a 1/4-20 x 1" serrated flange black bolt and (5) 1/4" pushnut bolt retainers onto the firewall cover as shown in Photos 3 and 4, below.
3. Temporarily install the firewall cover onto the firewall (See Photo 5, below). Using the firewall as a template, drill the remaining holes using a 5/16" drill bit. Remove the firewall cover.
4. Install a 1/4-20 x 1" serrated flange black bolt and a 1/4" pushnut bolt retainer in the upper mounting hole (See Photo 4, below).
5. Apply a 1/4" bead of silicone around the mating surface of the firewall cover.
6. Install the firewall cover onto the firewall. Secure it from the passenger compartment using (4) 1/4" USS flat washers and (4) 1/4-20 hex nuts with star washers (See Photo 6, below).

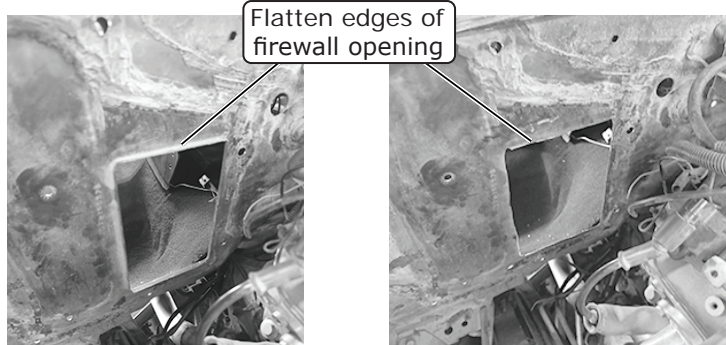

Flatten edges of firewall opening

Photo 1

Photo 2

1/4-20 x 1" Serrated Flange Black Bolts

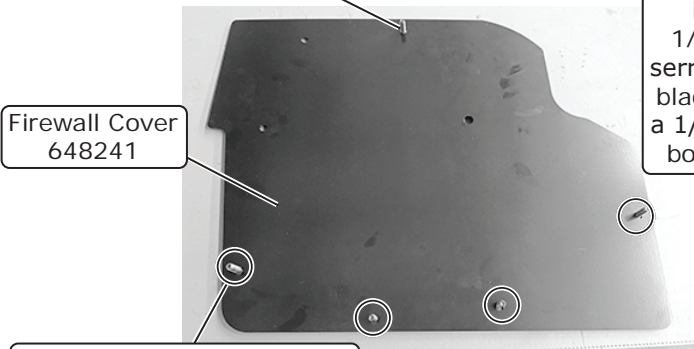

Firewall Cover 648241

(4) 1/4-20 x 3/4" Serrated Flange Black Bolts

Photo 3

Install a 1/4-20 x 1" serrated flange black bolt and a 1/4" pushnut bolt retainer

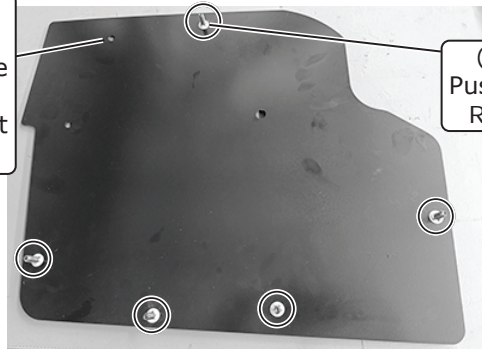

(5) 1/4" Pushnut Bolt Retainers

Photo 4

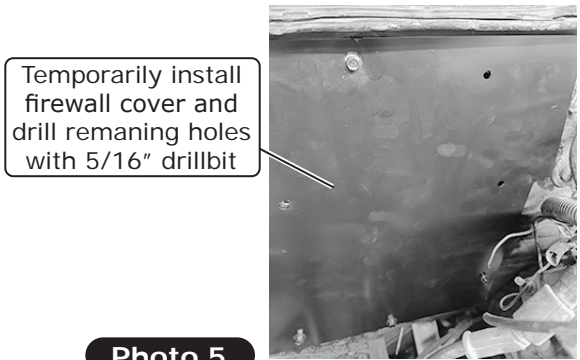

Temporarily install firewall cover and drill remaining holes with 5/16" drillbit

Photo 5

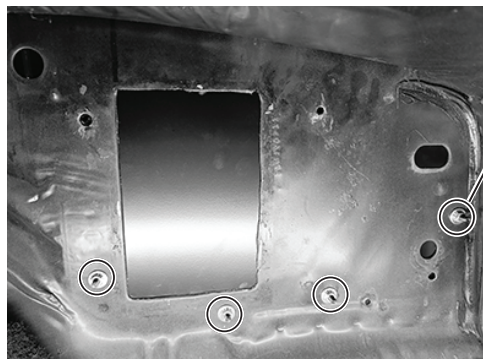

(4) 1/4" USS Flat Washers and (4) 1/4-20 Hex Nuts with Star Washers

Photo 6



www.vintageair.com

Firewall Modification, Firewall Cover Installation and Insulation (Cont.)

- Remove the cowl screen and the mounting hardware (See Photo 7, below). Install (2) 1/4-20 hex nuts with star washers onto the firewall bolts (See Photo 8, below). Reinstall the screen.
- Apply insulation (passenger compartment) at this time and cut out holes for the mounting hardware.

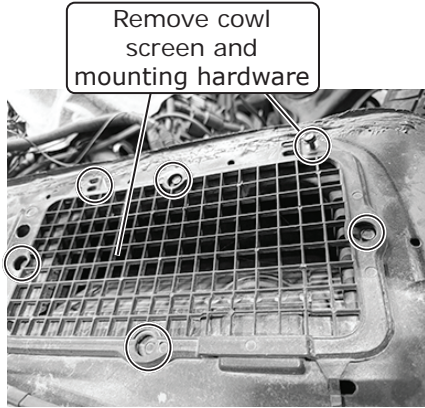

Photo 7

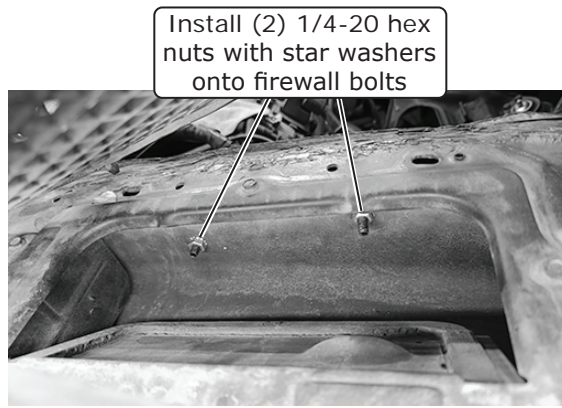

Photo 8

Defrost Duct Installation

- Secure a 24" length of 2 1/2" duct hose onto the driver-side defrost duct as shown in Figure 1, below. Secure a 24" length of 2 1/2" duct hose onto the passenger-side defrost duct.
- Install the (2) defrost ducts onto the OEM defrost duct mounting flanges under the dash using (2) #8 washers, (2) 10-24 x 3/4" serrated flange screws and (2) 10-24 nuts with star washers as shown in Photos 1, 2 and Figure 1, below.

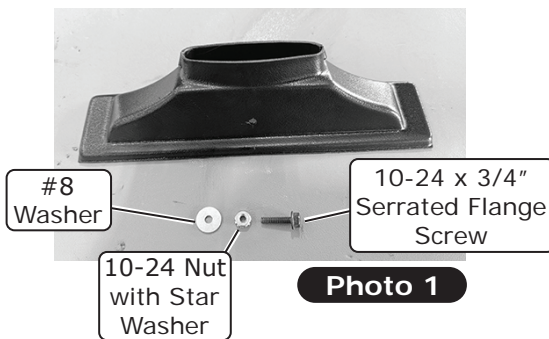

Photo 1



Photo 2

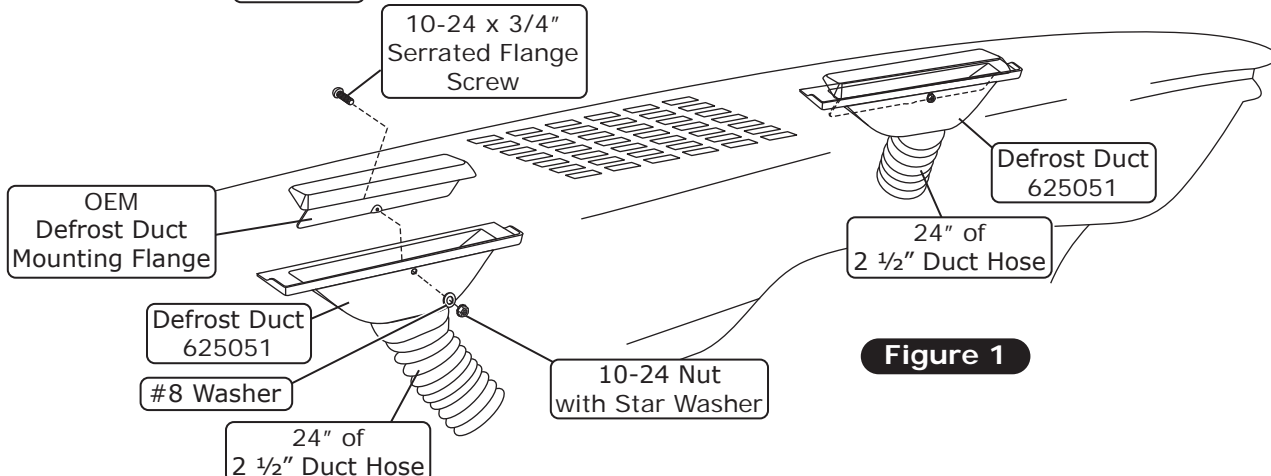

Figure 1



www.vintageair.com

Hose Adapter Installation

1. Locate the driver- and passenger-side hose adapters.
2. Install (2) S-clips ((1) on each side) onto the driver-side louver hose adapter as shown in Figure 1, below.
3. Secure 36" of 2 1/2" duct hose onto the driver-side louver hose adapter as shown in Figure 1, below.
4. Install the driver-side louver hose adapter onto the back side of the driver-side OEM louver as shown in Figure 1, below.
5. Secure 50" of 2 1/2" duct hose onto the passenger-side louver hose adapter as shown in Photo 1, below.
6. Using (3) OEM screws, install the passenger-side louver hose adapter onto the back side of the passenger-side louver as shown in Photo 1, below.
7. Locate the center louver hose adapter, and install (2) S-clips ((1) on the center top and (1) on the center bottom) as shown in Figure 2, below.
8. Secure 22" length of 2 1/2" duct hose onto the hose adapter as shown in Figure 2, below.
9. Install the hose adapter onto the back side of the OEM center louver as shown in Figure 2, below.

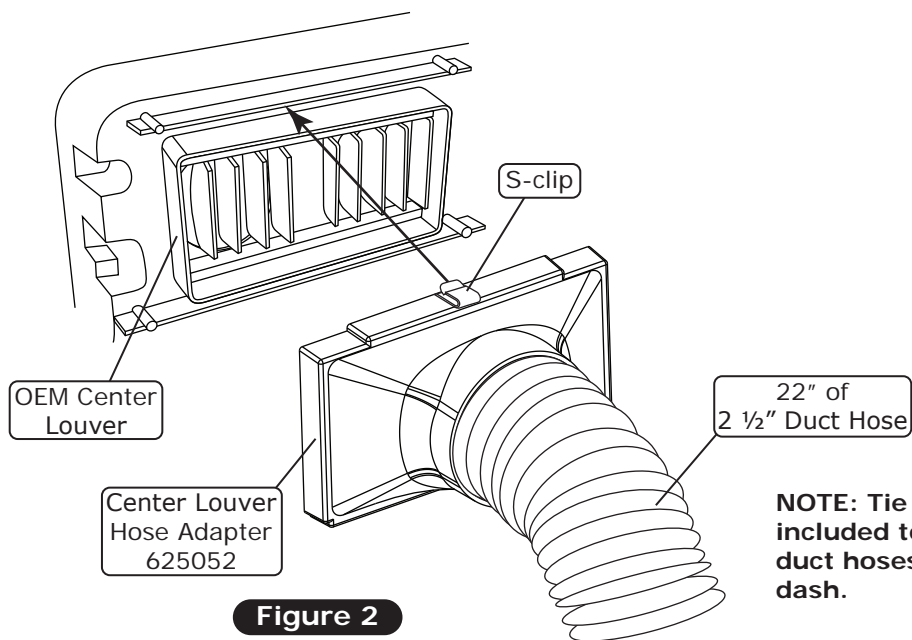
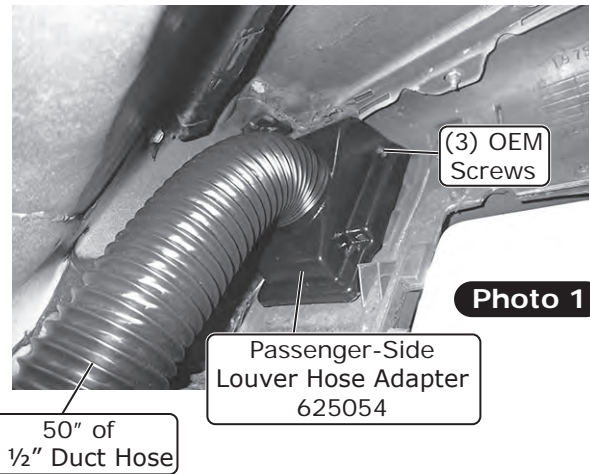
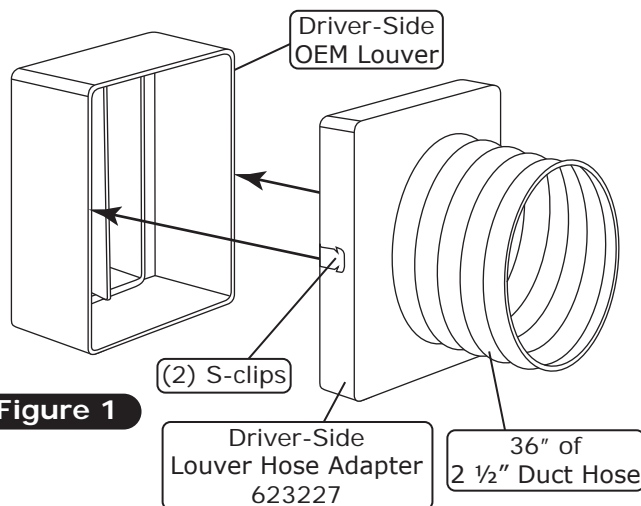

NOTE: Tie wraps are included to secure the duct hoses behind the dash.



www.vintageair.com

Passenger-Side Kick Panel & Fresh Air Cap Modification

1. Install (3) large grommets, a 1 1/4" O.D. x 1" with 1/2" hole grommet and a 7/8" O.D. x 3/8" I.D. grommet into the fresh air cap (See Photos 1 & 2, below).
2. On the inside of the fresh air cap, the letter "T" indicates the top mounting hole for the firewall (See Photo 3, below).
3. From the center of the bottom-left hole on the kick panel, measure 1 1/2" down. Mark and drill a 5/8" hole for the 7/8" grommet (See Photos 4 and 5, below).

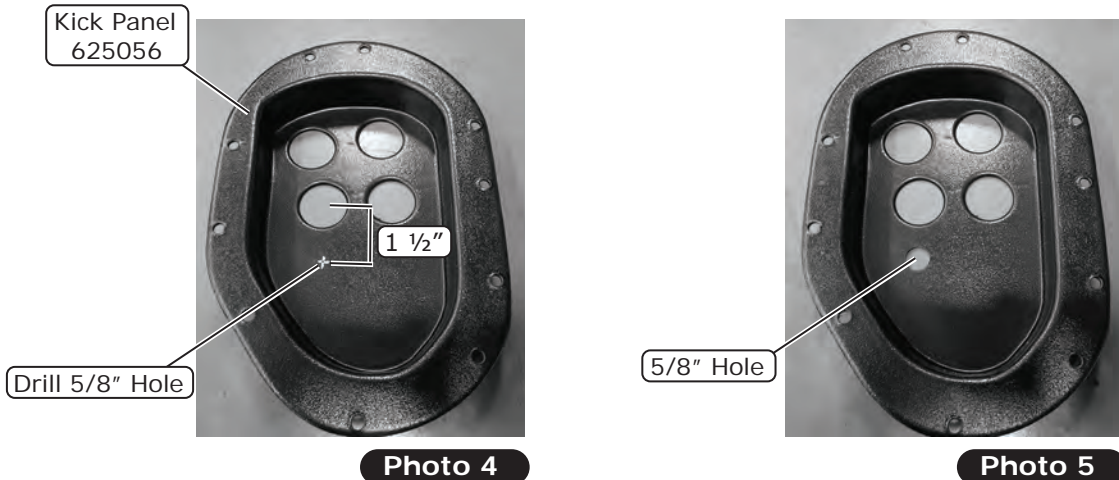
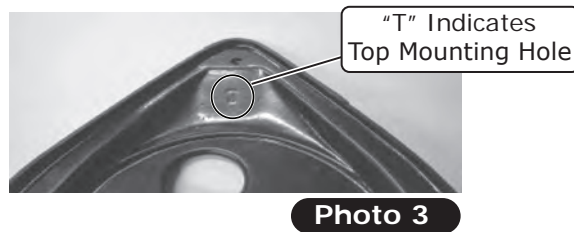
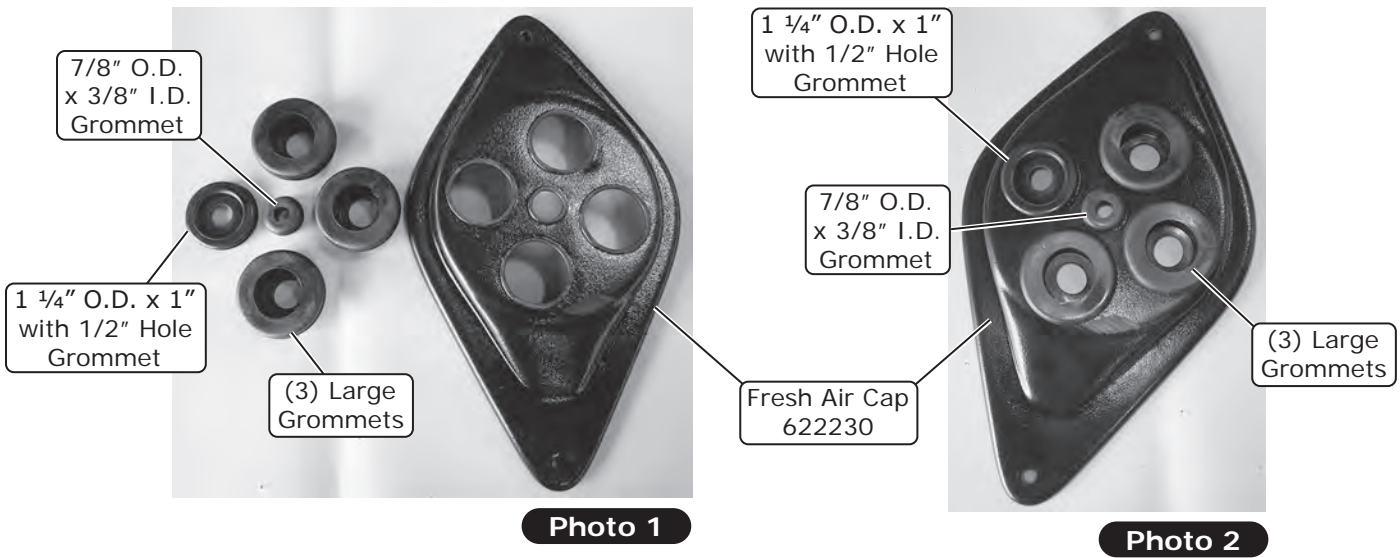



www.vintageair.com

Passenger-Side Kick Panel & Fresh Air Cap Modification (Cont.)

4. Install (3) large grommets, a 1 1/4" O.D. x 1" with 1/2" hole grommet and a 7/8" O.D. x 3/8" I.D. grommet into the kick panel (See Photos 6 and 7, below).
5. Locate the OEM passenger-side kick panel and kick panel fresh air cover.
6. On the kick panel, mark 3/8" out from the fresh air door assembly lip around the entire perimeter of the fresh air door assembly as shown in Figure 1, below. Cut out the section as shown.
7. Reinstall the vehicle's OEM kick panel trim, then make the necessary trim at the kick panel fresh air cover (See Figure 2, below). **NOTE: Retain the kick panel fresh air cover until after the evaporator module is installed.**

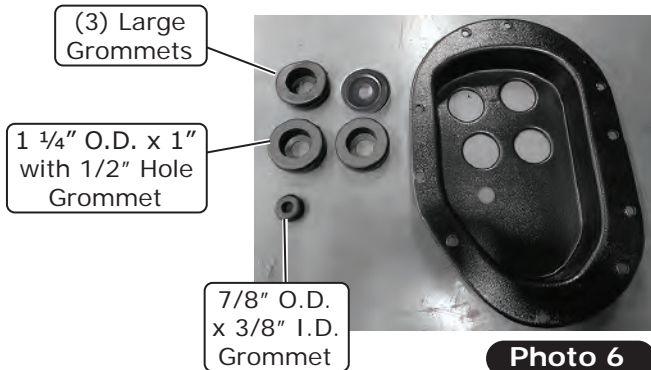

Photo 6



Grommets Installed

Photo 7

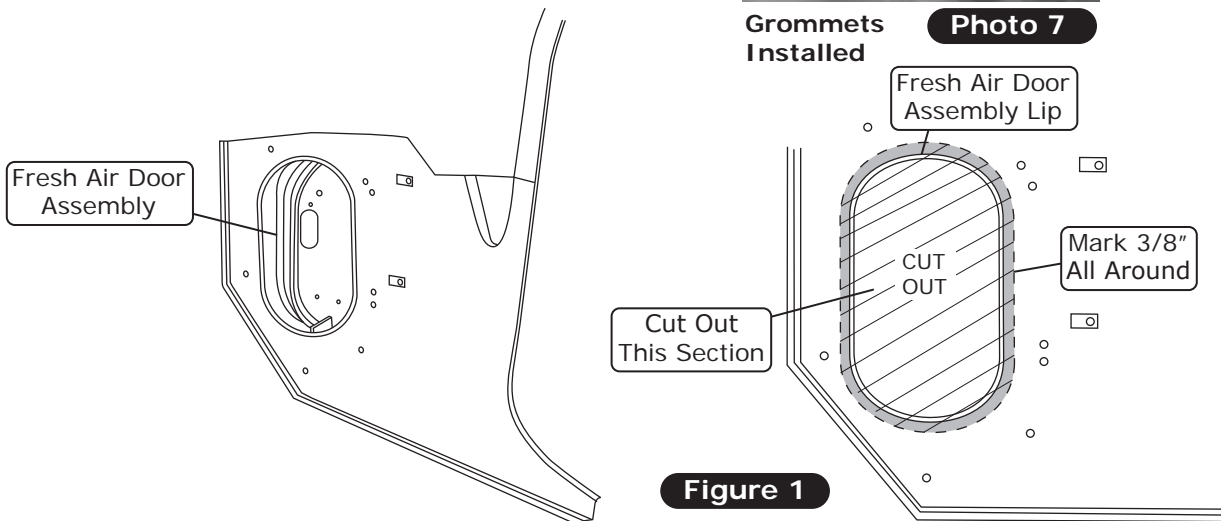

Figure 1

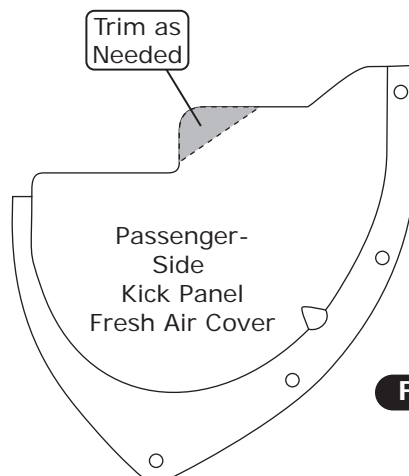

Figure 2



www.vintageair.com

Lubricating O-rings

For a proper seal of fittings: Install supplied O-rings as shown and lubricate with refrigerant oil.

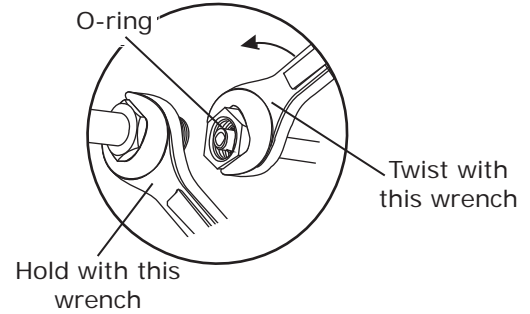
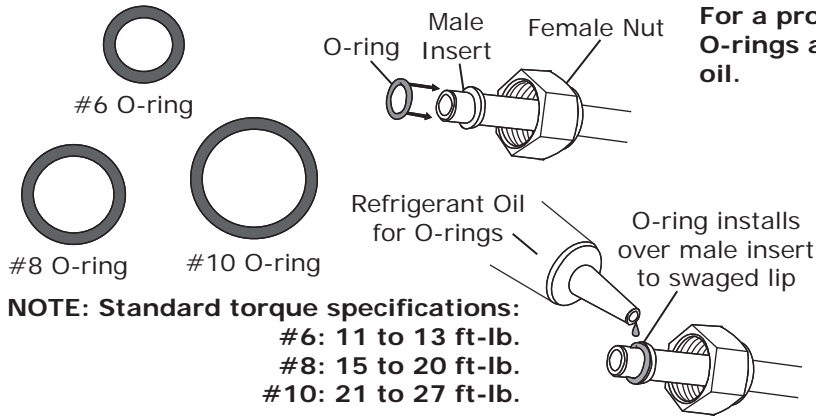

Properly Seated O-ring Land

When installing a hardline or A/C hose fitting onto the evaporator module, ensure the O-ring land is seated properly (See Photo 1, below). An improperly seated O-ring land (See Photo 2, below) can cause a leak. To properly install the fitting, slide the hardline or A/C hose nut back to expose the O-ring land and seat it onto the evaporator module fitting. Then, slide the hardline or A/C hose nut forward and thread it onto the evaporator module fitting, ensuring the O-ring land does not move or lift.

Properly Seated O-ring Land



Photo 1

Improperly Seated O-ring Land

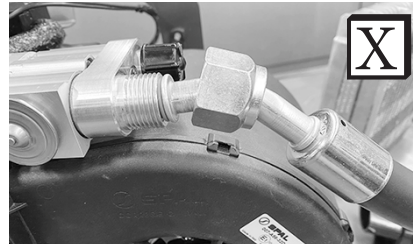

Photo 2

NOTE: Photos shown are for reference only. Fittings may vary depending on kit received.



www.vintageair.com

Evaporator Preparation

Perform the following on a workbench:

1. Remove the plastic caps and rubber inserts from the heater connections (See Photos 1 and 2, below).
2. Install the upper and lower heater hardlines onto the evaporator module using (2) properly lubricated #10 O-rings (See Lubricating O-rings, Page 16, and Photo 3, below).
3. Install (3) 1/2" plastic plugs, into the back of the evaporator module (See Photos 4 and 5, below).
NOTE: These mounting positions will not be used for this application.
4. Install the evaporator firewall bracket onto the module and secure it using (4) #10 x 5/8" screws (See Photos 6 and 7, below).
5. Install (2) 1/4-20 full-threaded studs halfway into the mounting holes on the evaporator firewall bracket (See Photo 8, below).

Remove plastic caps and rubber inserts

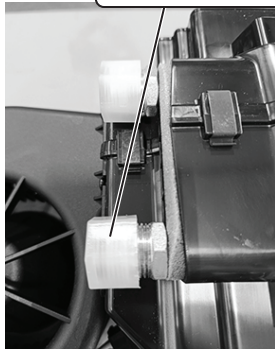

Photo 1



Photo 2

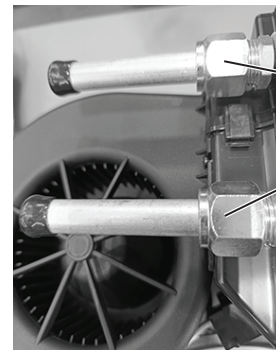

Photo 3

Install upper and lower heater hardlines

Install (3) 1/2" plastic plugs into back of evaporator module



Photo 4



Photo 5

(3) 1/2" Plastic Plugs

(2) #10 x 5/8 Screws

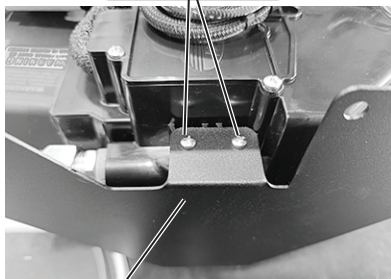

Evaporator Firewall Bracket 648245

Photo 6

(2) #10 x 5/8 Screws

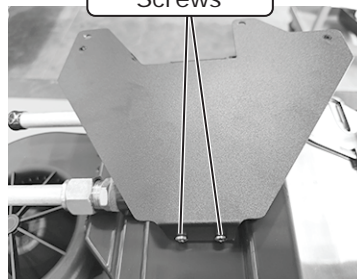

Photo 7

Install (2) 1/4-20 full-threaded studs

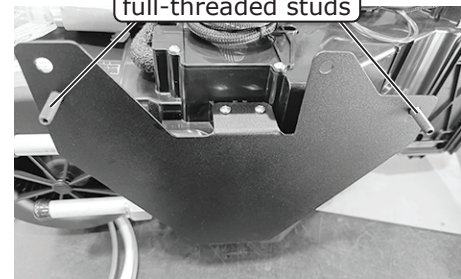

Photo 8



www.vintageair.com

Evaporator Preparation (Cont.)

6. Install (2) 1/4-20 well nuts into the front mounting provisions (See Photos 9 and 10, below).
7. Secure the evaporator cowl bracket using (2) 1/4-20 x 1" serrated flange bolts (See Photo 11, below).
8. Using (4) spring clips, install the dash plenum onto the evaporator module (See Photos 12 and 13, below).
9. Using (2) spring clips, install the floor plenum onto the back of the evaporator module (See Photo 14, below).
10. Using (2) spring clips, install the 2-vent plenum onto the front of the evaporator module (See Photo 15, below).

Install (2) 1/4-20 well nuts into front mounting provisions

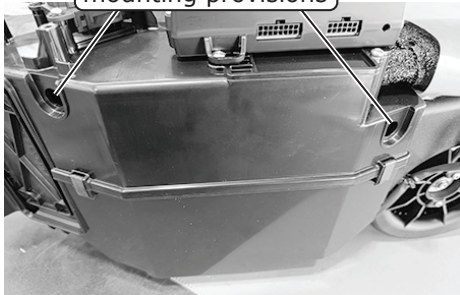

Photo 9

(2) 1/4-20 Well Nuts

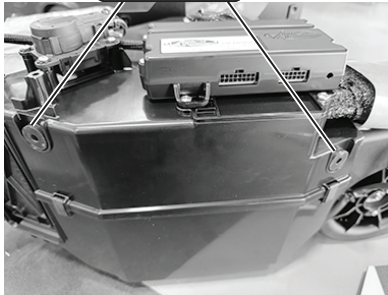
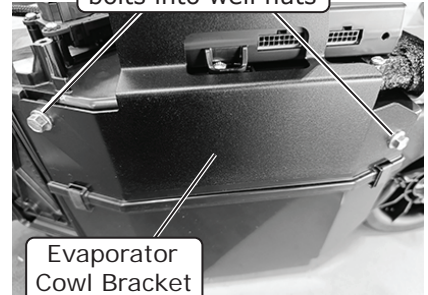

Photo 10

Install (2) 1/4-20 x 1" serrated flange bolts into well nuts



Evaporator Cowl Bracket 648242

Photo 11

Dash Plenum 625330



Photo 12

Using (4) spring clips, install dash plenum

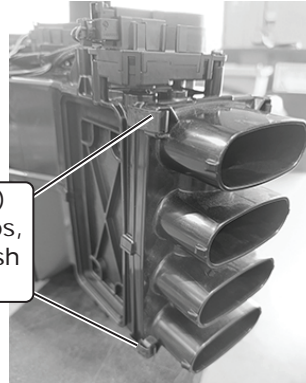

Photo 13

Using (2) spring clips, install floor plenum

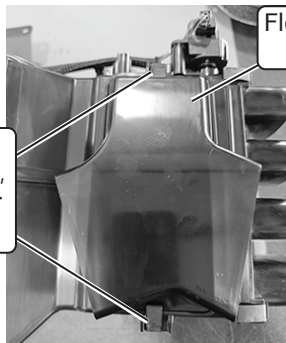

Photo 14

Floor Plenum 625338

2-Vent Plenum 629905

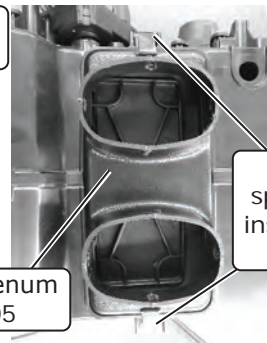

Photo 15

Using (2) spring clips, install 2-vent plenum



www.vintageair.com

Wiring Installation

1. Locate the heater control valve plug on the main wiring harness (white/yellow/purple). Route it through the 7/8" wiring grommet on the kick panel (See Photo 1, below) and into the kick panel opening. Then, through the wiring grommet on the fresh air cap (See Photo 2, below) and into the engine compartment.
2. Route the red, white and blue wires from the main harness through the 7/8" wiring grommet on the kick panel cover (See Photo 3, below) and into the kick panel opening. Then, through the wiring grommet on the fresh air cap and into the engine compartment (See Photo 4, below).
3. Leave approximately 16" of wiring between the kick panel and relay.
4. Place the evaporator module on the passenger-side floorboard.
5. Route the heavy gauge orange and white wires through the wiring grommet in the kick panel (See Photo 5, below) and into the kick panel opening. Then, through the wiring grommet on the fresh air cap and into the engine compartment (See Photo 6, below).

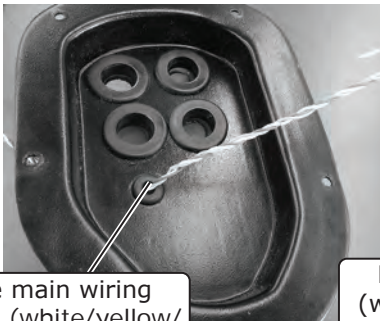

Route main wiring harness (white/yellow/purple) through 7/8" wiring grommet on kick panel

Photo 1

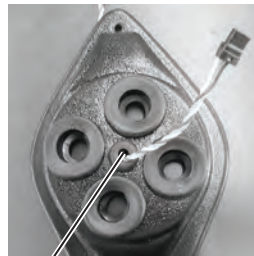

Route main wiring harness (white/yellow/purple) through wiring grommet on fresh air cap

Photo 2

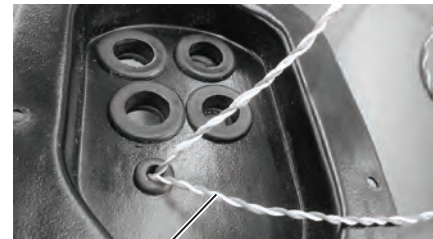

Route red, white and blue wires from main harness through 7/8" wiring grommet on kick panel

Photo 3

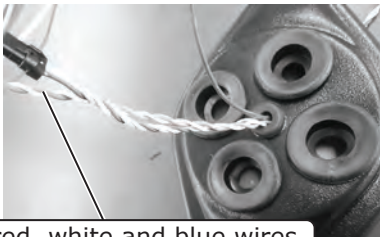

Route red, white and blue wires from main harness through 7/8" wiring grommet on fresh air cap

Photo 4



Route heavy gauge orange and white wires through 7/8" wiring grommet on kick panel

Photo 5

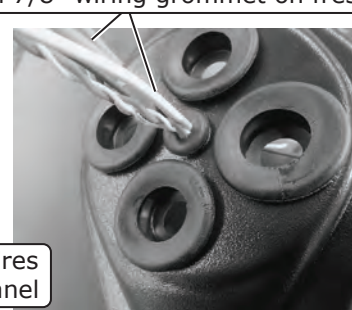

Photo 6



www.vintageair.com

Kick Panel Cover Installation

1. Route the 45° fittings of the #6 and #10 A/C hoses and the heater hoses through the fresh air cap into the passenger compartment (See Photo 1, below).
2. Route the A/C and heater hoses through the kick panel (See Figure 1, below).
3. Apply 1/4" bead of silicone around the mating surface of the kick panel.
4. Secure the kick panel using (5) #8 x 1 1/4" countersunk screws with washers (See Figure 1, below).

Route 45° fittings of #6 and #10 A/C hoses and heater hoses through fresh air cap into passenger compartment

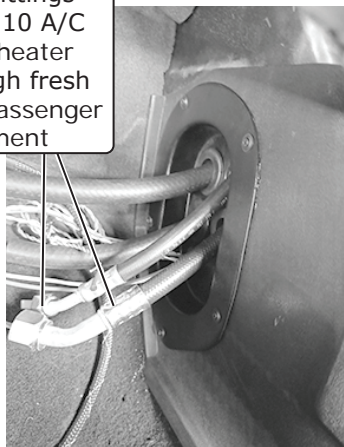

Photo 1

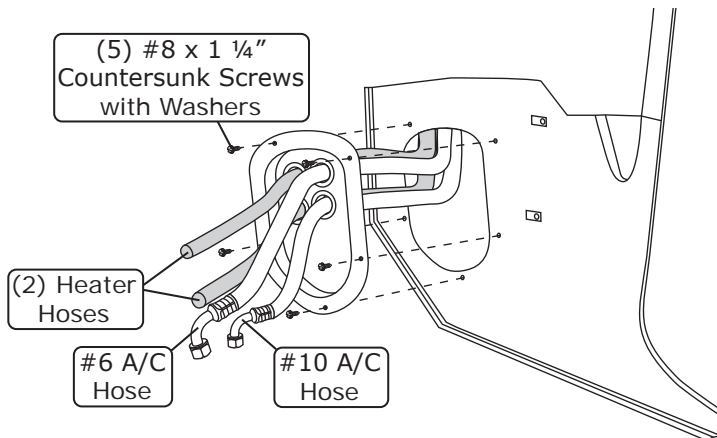

Figure 1

Fresh Air Cap Installation

NOTE: The fresh air cap installs on the engine side of the firewall.

1. Slide the fresh air cap into position and secure it to the firewall using (2) #14 x 3/4" washer head screws (See Photo 1, below).
2. Apply silicone around the outer edge of the fresh air cap.

Apply silicone around outer edge of fresh air cap

Secure fresh air cap with (2) #14 x 3/4" washer head screws

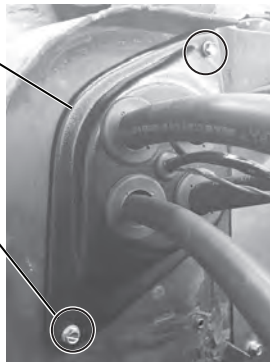

Photo 1



www.vintageair.com

Evaporator Installation

NOTE: To ensure a watertight seal between the passenger compartment and the vehicle exterior, for all bolts passing through the firewall, Vintage Air recommends coating the threads with silicone prior to installation.

1. With the evaporator module on the passenger-side floorboard, install the upper and lower heater hoses and hose clamps onto the upper and lower heater hardlines on the evaporator module (See Photos 1 and 2, below).
2. Lift the evaporator module up under the dashboard. Using the full-length studs, locate the upper mounting holes in the firewall (See Photo 3, below). **NOTE: When lifting up the evaporator module, be careful to prevent damage to the drain outlet located at the bottom of the evaporator module. Feed the hoses into or out of the kick panel fresh air cap as needed while lifting the evaporator module into position.**
3. Level the evaporator module front to back and left to right, then secure the cowl bracket to the cowl using (2) #14 x 3/4" washer head screws (See Photo 4, below).
4. Using a properly lubricated #6 O-ring (See Lubricating O-rings, Page 16), connect the #6 45° fitting to the block fitting adapter (See Photo 5, below).
5. Using a properly lubricated #10 O-ring (See Lubricating O-rings, Page 16), connect the #10 45° fitting to the block fitting adapter. Install press tape all around the #10 A/C hose fitting as shown in Photo 6, below.
6. From the engine compartment, replace the full-length studs with (2) 1/4-20 x 3/4" serrated flange black bolts (See Photo 7, below).
7. Connect the blower speed controller plug into the main wiring harness plug (orange and green wires) (See Photo 8, below).



Upper and lower heater hardlines

Photo 1

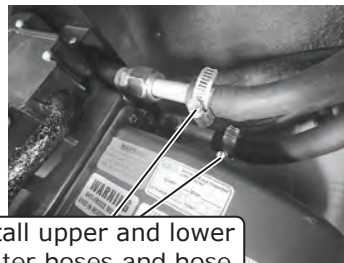

Install upper and lower heater hoses and hose clamps onto upper and lower heater hardlines

Photo 2

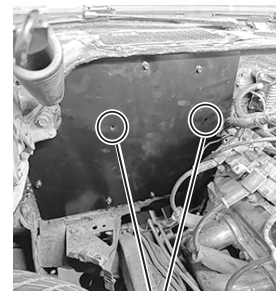

Using full-length studs locate upper mounting holes in firewall

Photo 3

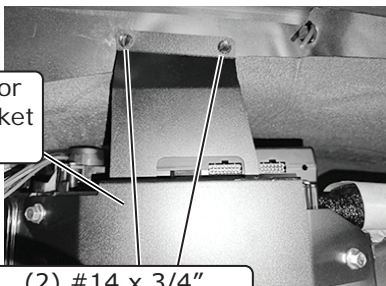

Evaporator Cowl Bracket 648242

(2) #14 x 3/4" Washer Head Screws

Photo 4

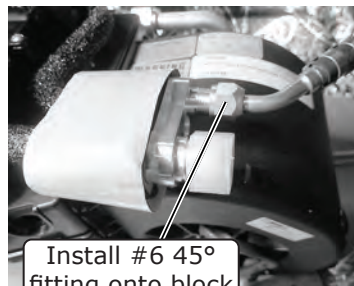

Install #6 45° fitting onto block fitting adapter

Photo 5

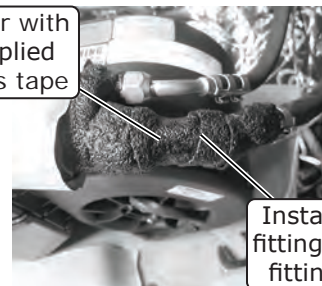

Cover with supplied press tape

Install #10 45° fitting onto block fitting adapter

Photo 6

(2) 1/4-20 x 3/4" Serrated Flange Black Bolts

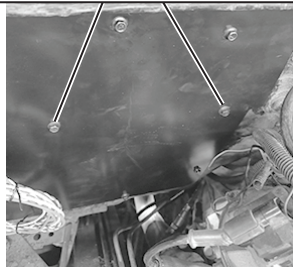
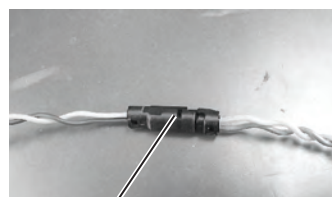

Photo 7



Connect blower speed controller plug into main wiring harness plug (orange and green wires)

Photo 8



www.vintageair.com

Drain Hose Installation

1. Locate the evaporator drain on the bottom of the evaporator module.
2. In line with the drain, lightly make a mark on firewall. Then, measure 1" down and drill a 5/8" hole through the firewall (See Figure 1, below).
3. Install the drain hose onto the evaporator drain on the bottom of the module, and route through the firewall.

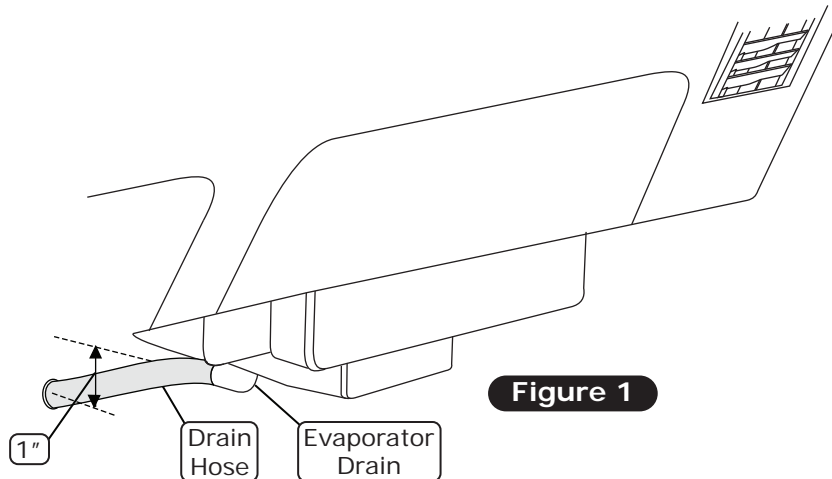

Under Dash Hose Adapter Assembly Installation

1. Locate the driver-side under dash hose adapter assembly, and place it onto the bottom flange of the dash support brace under the steering column (See Figure 1, below). Center the hose adapter assembly onto the opening, and drill a 7/64" hole from the bottom flange of the support brace and through the hose adapter assembly (See Figure 1, below). Secure using a #8 x 1/2" pan head screw (See Figure 1, below).
2. Locate the passenger-side under dash hose adapter assembly, and install it onto the A/C duct located on the dash support brace under the glove box (See Figure 1, below). Drill (2) 7/64" holes through the duct and hose adapter assembly (See Figure 1, below). Secure using (2) #8 x 1/2" pan head screws (See Figure 1, below).

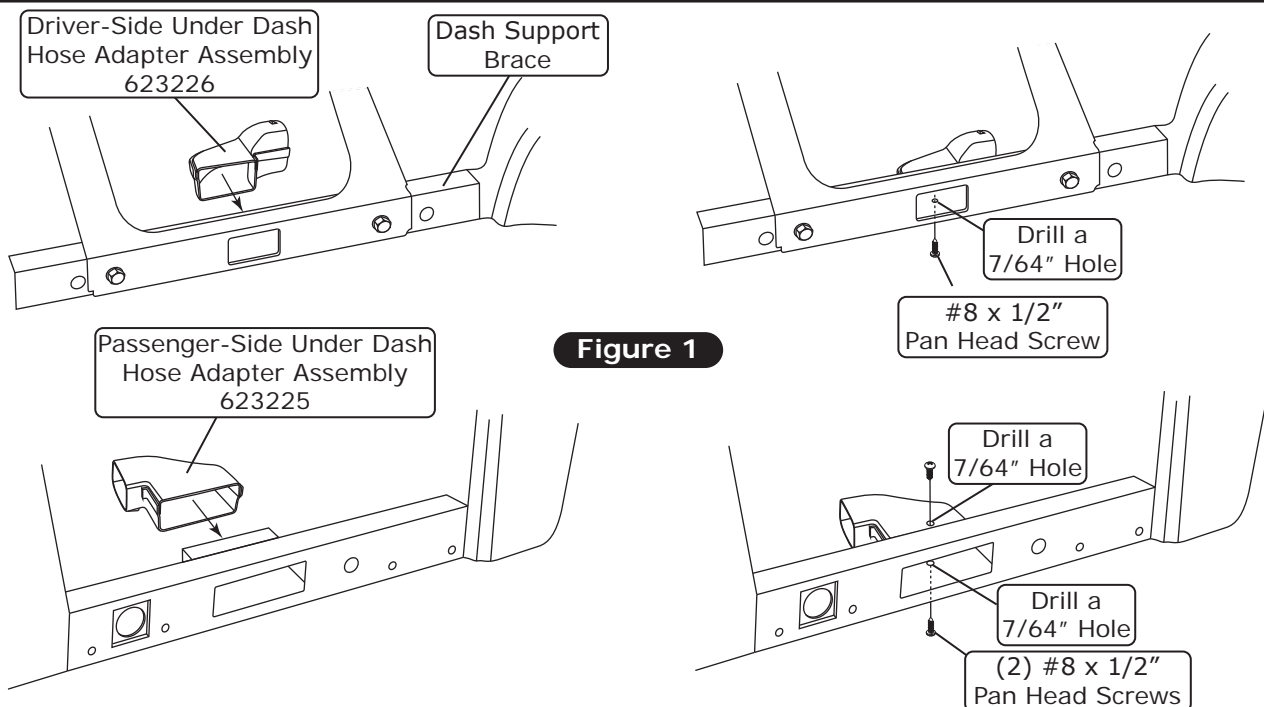



www.vintageair.com

Driver-Side Under Dash Cover Installation

1. Loosen (2) bolts on the dash support brace under the steering column (See Photo 1, below).
2. Install the driver-side under dash cover and tighten the screws (See Photo 1, below).
3. Reinstall the OEM plastic steering column cover.

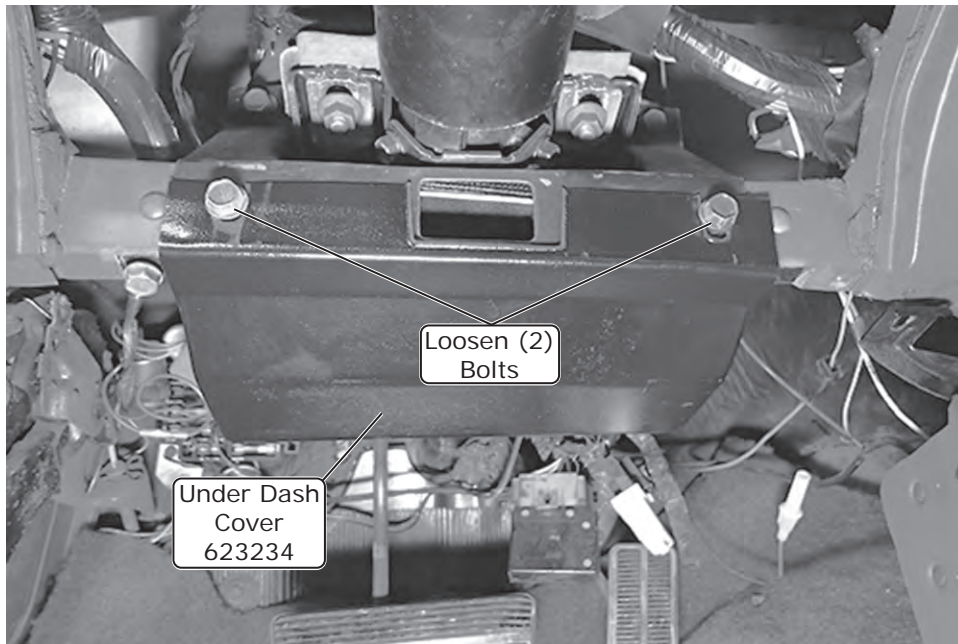

Photo 1



www.vintageair.com

Duct Hose Routing

NOTE: For the system to function optimally, the duct hoses must be routed as directly as possible, taking care to avoid kinks, sharp bends and unnecessary length. Vintage Air supplies duct hoses in continuous lengths that will need to be cut to size depending on application. Before cutting, familiarize yourself with the installation instructions and verify the routing will work with your application. For custom hose routing, additional hose may be needed and can be purchased from Vintage Air.

1. Stretch the duct hose until there is no slack, measure, mark and cut hose to size (See Photo 1, below).

Stretch, measure, mark and cut hose to size



Photo 1

Disclaimer: Before cutting duct hose to length, verify the routing will work for your application.

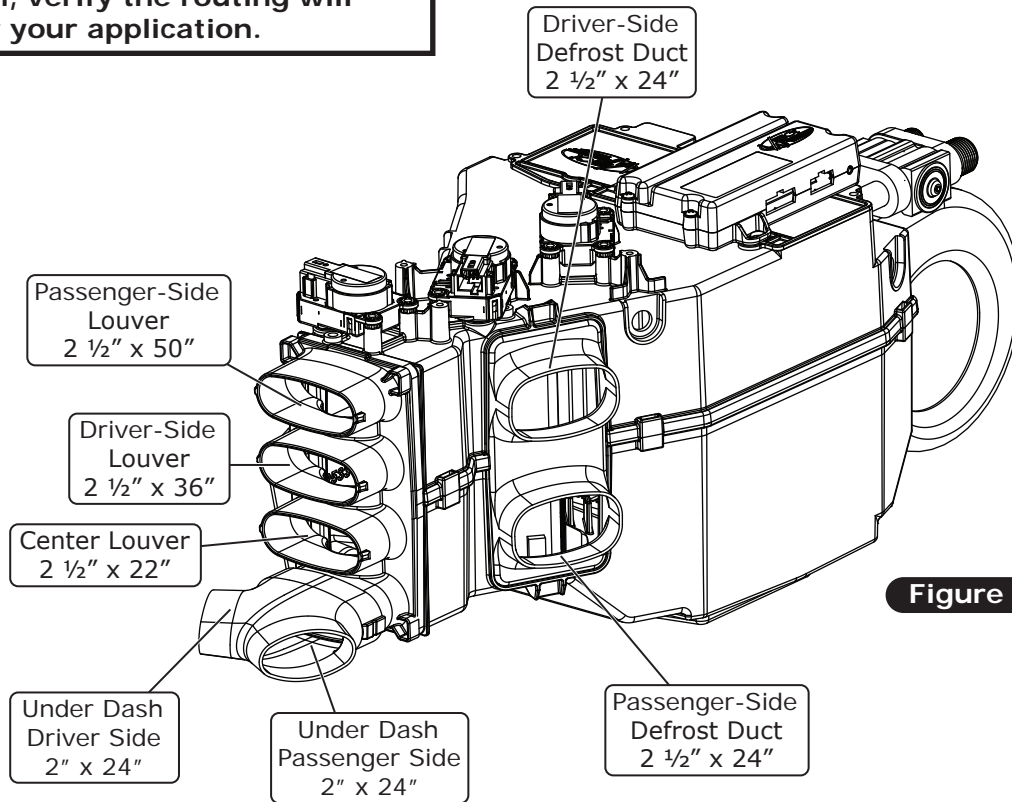

Figure 1



NOTE: ECU must be placed away from water and humidity, and also be accessible for servicing. If relocating, connectors must be positioned towards the bottom.

Position connectors towards bottom



www.vintageair.com

Heater Hose & Heater Control Valve Installation

NOTE: Vintage Air Systems use 5/8" heater connections. On engines equipped with 3/4" hose nipples, these will need to be removed and replaced with 5/8" nipples (not supplied). For water pumps with a cast-in 3/4" heater outlet, a 3/4" x 5/8" reducer fitting (not supplied) will need to be installed in the heater hose.

1. Route a piece of heater hose from the water pump to the upper heater core fitting (See Photo 1, below, and Figure 1, below). Secure using hose clamps.
2. Route a piece of heater hose from the intake to the heater control valve, and from the heater control valve to the lower heater core fitting (See Photo 1 and Figure 1, below). **NOTE: Install the heater control valve in line with the intake manifold (pressure side) heater hose, and secure using hose clamps. Also note proper flow direction.**

A/C and Heater Hose Routing

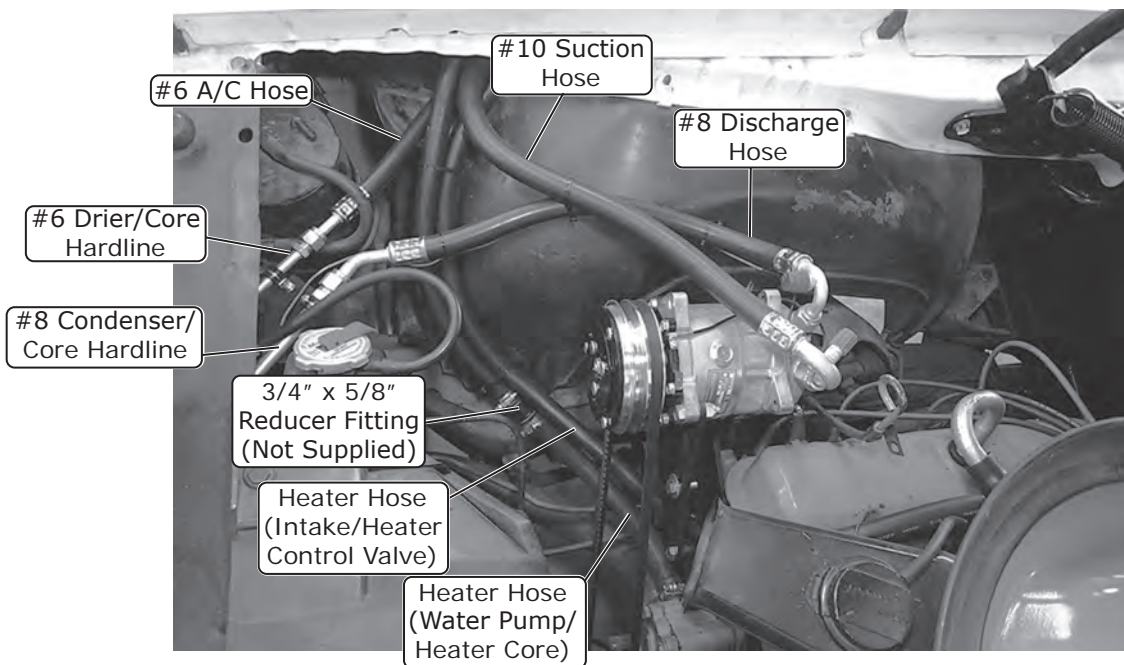

Photo 1

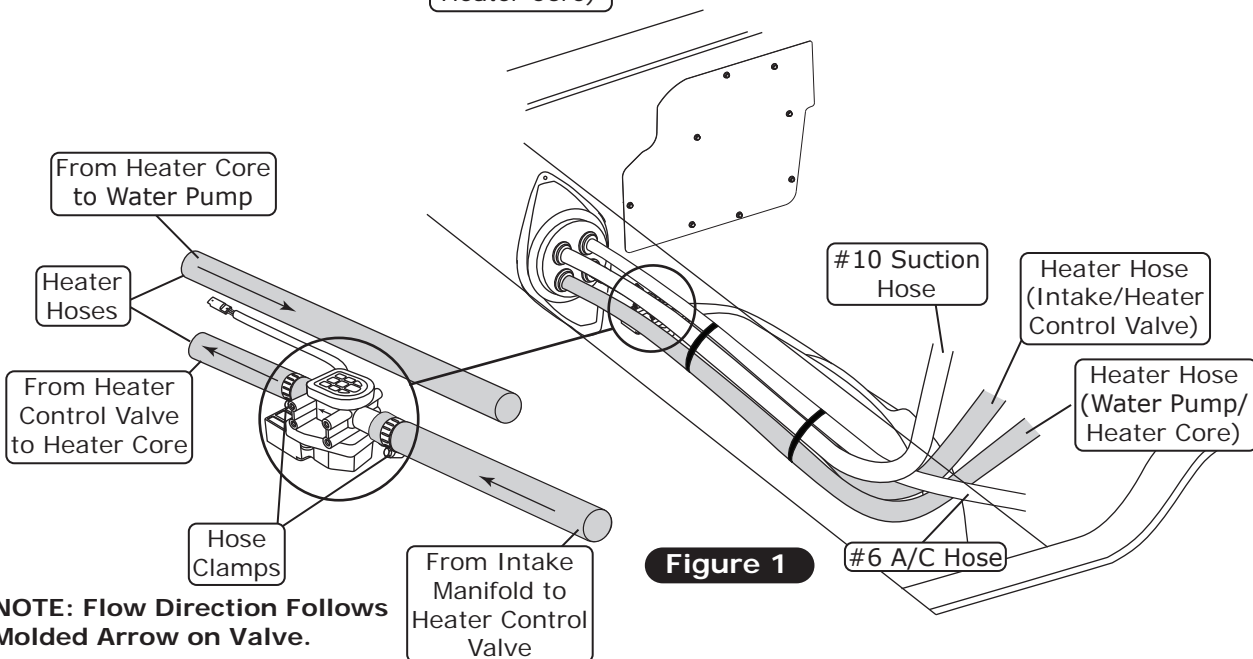

Figure 1

NOTE: Flow Direction Follows Molded Arrow on Valve.



www.vintageair.com

Engine Compartment Wiring

1. Route power and ground wires toward the battery.
 2. Install the supplied heat shrink over the 12 AWG orange fuse holder assembly wire, and crimp it to the 12 AWG orange wire from the main wiring harness (See Photo 1, below and Quality Crimp Guidelines, Page 29).
 3. Install the supplied heat shrink over the 16 AWG black fuse holder assembly wire, and crimp it to the 16 AWG red wire from the main wiring harness (See Photo 2, below and Quality Crimp Guidelines, Page 29).
 4. Install fuses into the holders (See Photo 3, below).
 5. Install the supplied heat shrink over the white ground wires, then crimp on the supplied eyelets (See Photos 4 and 5, below and Quality Crimp Guidelines, Page 29)
 6. Connect the ground wiring eyelets to the negative battery terminal connector (See Photo 6, below).
 7. Connect the positive wiring eyelets to the positive battery terminal connector (See Photo 7, below).
- NOTE: Do not connect power until installation is completed.**

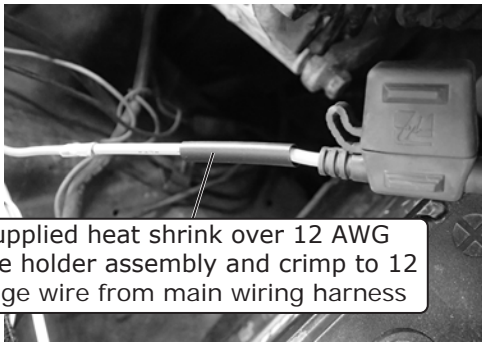

Install supplied heat shrink over 12 AWG orange fuse holder assembly and crimp to 12 AWG orange wire from main wiring harness

Photo 1

Install supplied heat shrink over 16 AWG black fuse holder assembly wire and crimp to 16 AWG red wire from main wiring harness

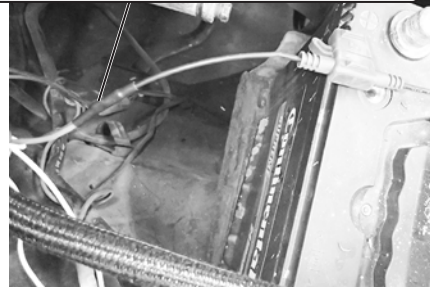
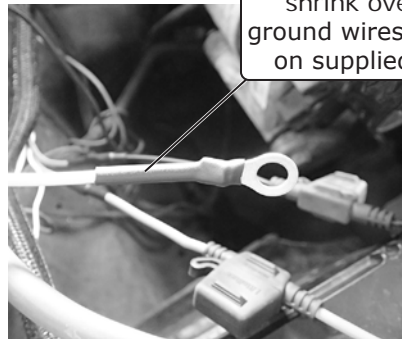

Photo 2



Install fuses into holders

Photo 3



Install supplied heat shrink over white ground wires and crimp on supplied eyelets

Photo 4

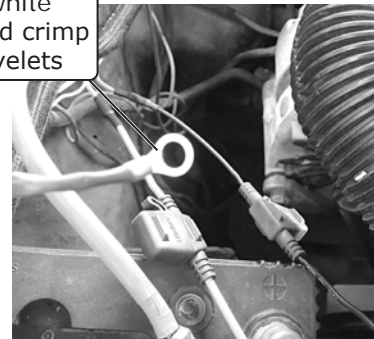
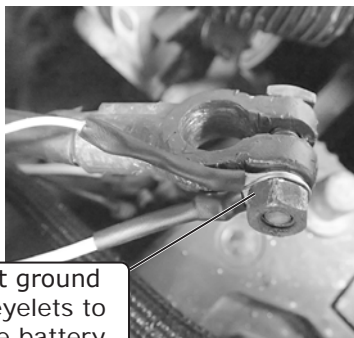
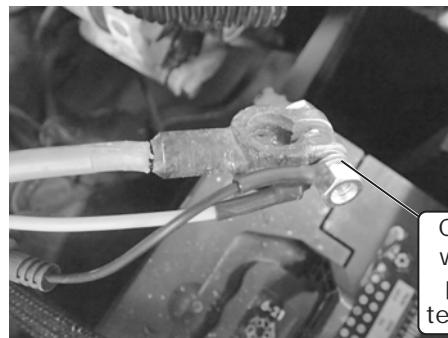

Photo 5



Connect ground wiring eyelets to negative battery terminal connector

Photo 6



Connect positive wiring eyelets to positive battery terminal connector

Photo 7

NOTE: Do not connect power until installation is completed.



www.vintageair.com

Final Steps: Installation Check

| Installation Check | |
|--------------------------|---|
| ITEM TO CHECK | Procedure |
| <input type="checkbox"/> | <p>ECU</p> <p>If no blinking is observed after 1 minute of turning the ignition on, go to the next check.</p> <p>If repetitive blinking is observed, go to the Advanced Diagnostics Section to diagnose.</p> |
| <input type="checkbox"/> | <p>Blower speed control</p> <p>Set the blower speed control to OFF, <u>confirm that the blower is off</u>.</p> <p>Position the blower speed control to LOW then MEDIUM and then HIGH. <u>At each setting confirm that the blower speed increases</u>, do this by feeling for the amount of air coming from the unit and hearing the blower speed increase.</p> |
| <input type="checkbox"/> | <p>Mode control</p> <p>Set the MODE control to the DASH position. <u>Confirm that air is being blown at the dash vents</u>.</p> <p>Set the MODE control to the FLOOR position. <u>Confirm that air is being blown at the floor vents</u>.</p> <p>Set the MODE control to the DEFROST position. <u>Confirm that all air is being blown from the defrost vents</u></p> <p>If heater lines are installed:</p> <p>Set the MODE control to the DASH position. Set the TEMP control to the MAX HEAT position. <u>Confirm that HOT air is coming from the dash vents</u>.</p> |
| <input type="checkbox"/> | <p>Temperature control</p> <p>If system is charged:</p> <p>Set the TEMP control to the MAX COOL position. <u>Confirm that COLD air is coming from the dash vents</u>.</p> <p>Also <u>confirm that the compressor "clicks" on</u> when adjusting the TEMP control from the MAX HEAT position to the MAX COOL position.</p> |
| <input type="checkbox"/> | <p>AC Indicator (If applicable)</p> <p>While the MODE control is set to the DASH position, and the TEMP control is set to the MAX COOL/MIN HEAT position, <u>confirm that the blue AC Indicator light is on</u>.</p> |
| <input type="checkbox"/> | <p>Backlight (If applicable)</p> <p>If your control panel has backlight capabilities and has been wired, turn the dash lamp on and <u>confirm that the AC panel's legend is lit</u>.</p> |
| <input type="checkbox"/> | <p>Fittings</p> <p>Verify AC and Heater fittings are all tight.</p> |



www.vintageair.com

Final Steps: Completing the Install

1. Install the duct hoses as shown in Duct Hose Routing, Page 24.
2. Install the control panel assembly. Refer to control panel instructions.
3. Plug the wiring harnesses into the ECU module on the evaporator. Wire according to wiring diagrams on Pages 30 and 31.
4. Reinstall all previously removed items.
5. Fill radiator with at least a 50/50 mixture of approved antifreeze and distilled water. It is the owner's responsibility to keep the freeze protection at the proper level for the climate in which the vehicle is operated. Failure to follow antifreeze recommendations will cause heater core to corrode prematurely and possibly burst in A/C mode and/or freezing weather, voiding your warranty.
6. Double check all fittings, brackets and belts for tightness.
7. Vintage Air recommends that all A/C systems be serviced by a licensed automotive A/C technician.
8. Evacuate the system for a minimum of 45 minutes prior to charging, and perform a leak check prior to servicing.
9. Charge the system to the capacities stated on Page 4 of this instruction manual.
10. See Operation of Controls procedures on Page 32.

Glove Box Installation

1. Install the new glove box provided with the kit, and secure using OEM screws as shown in Photo 1, below.
2. Reinstall the glove box door.

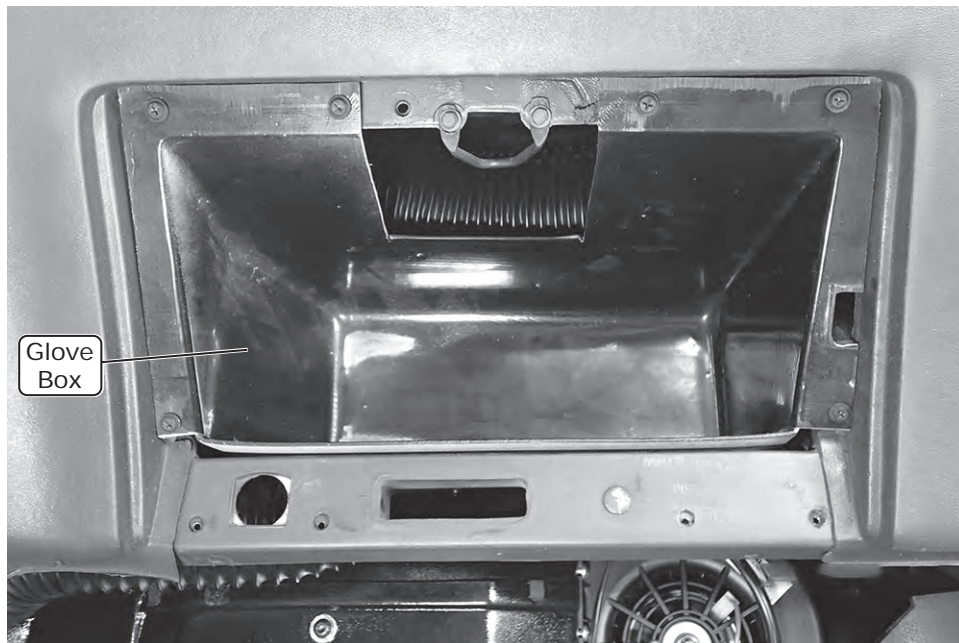

Photo 1



www.vintageair.com

Quality Crimp Guideline

Acceptable strip length
(Some copper visible)

Crimped area is centered
on each side of splice

Bad strip length
(Too much copper visible)
Visible copper should be
just enough to ensure
clearance between splice
area and wire insulation

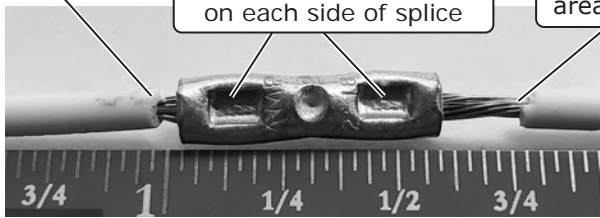

Photo 1

A good crimp requires
seam of butt splice to be
opposite of crimp die tooth



Crimp die tooth

Photo 2

Good Ring Terminal Crimp Bad Ring Terminal Crimp

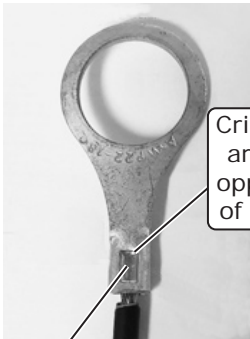

Crimped
area is
opposite
of seam

Photo 3

Crimp
area is
centered
on barrel

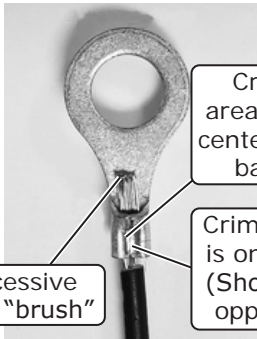

Crimp
area is not
centered on
barrel

Excessive
wire "brush"

Crimp area
is on seam
(Should be
opposite)

Photo 4



Photo 5

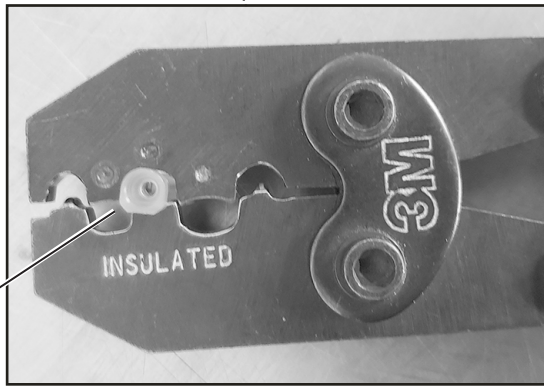

Photo 5a

Use a ratcheting crimp tool
for insulated barrel terminals
when crimping the provided
female insulated terminal.
Ensure terminal is inserted in
appropriate position before
crimping.



www.vintageair.com

Gen 5 Wiring Diagram

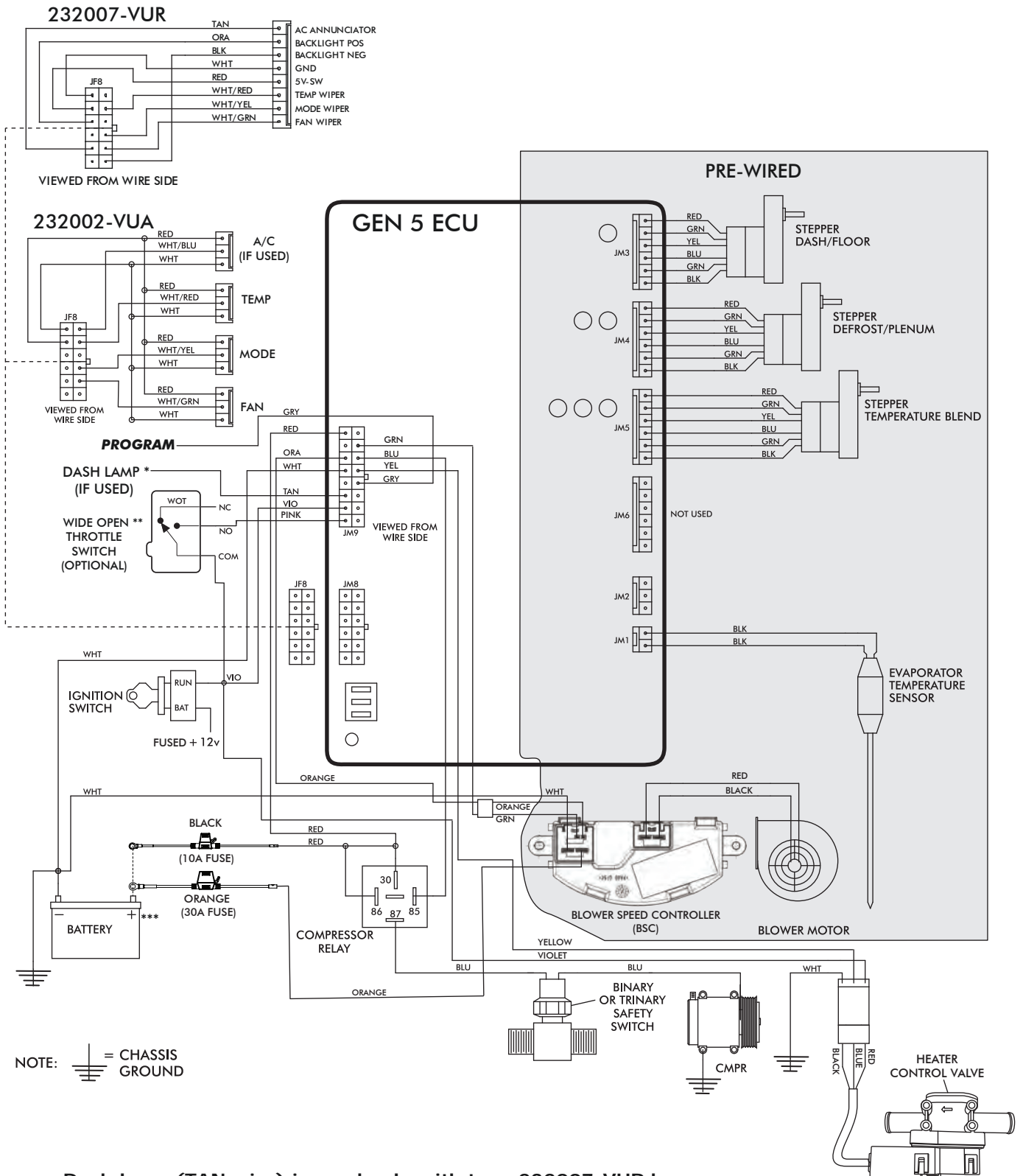

* Dash lamp (TAN wire) is used only with type 232007-VUR harness.

** Wide open throttle switch contacts close only at full throttle, which disables A/C compressor.

*** Install fuse assemblies at or as near to the battery as possible.



www.vintageair.com

Gen 5 Wiring Instructions

WIRING HARNESS (231505) ↓

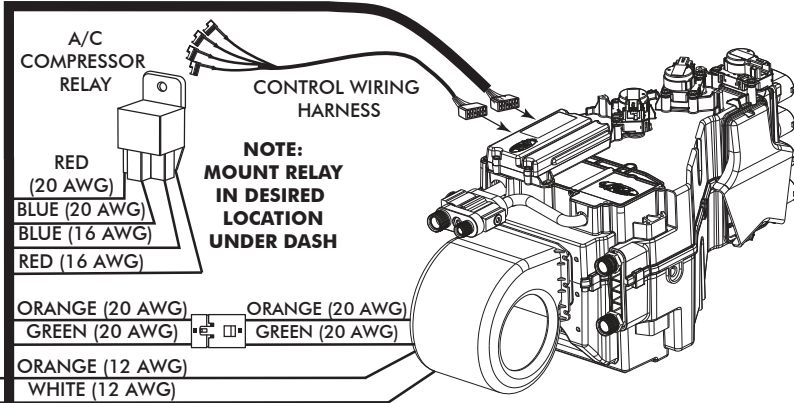

Ignition Switch:
Using provided butt splice (PN 226004), connect the 20 AWG violet wire to a 5A fused and switched 12V source such as Key On.

Wide Open Throttle Switch (Optional):
If a wide open throttle switch is required, connect the 20 AWG pink wire to a normally open switch that, when closed, connects a fused and switched 12V source to the pink wire. See Gen 5 wiring diagram for an example.

Dash Light (Optional):
If using a Vintage Air control panel with back light, connect the 20 AWG tan wire to the vehicle's dash back light 0-12V using provided butt splice (PN 226004).

WIRING HARNESS (232020) →

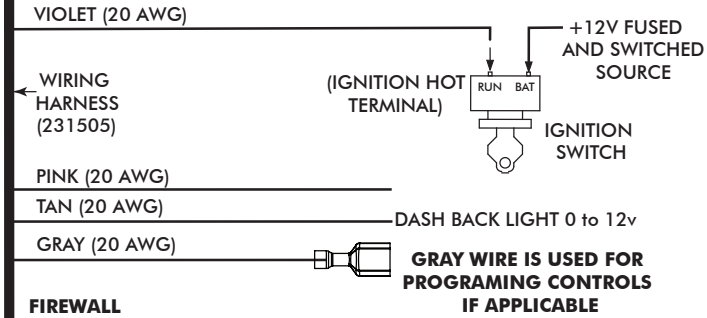

Heater Control Valve:
Connect the Violet/Yellow/White twisted branch with 3 position connector into the heater control valve connector. Ensure that the mating latch is fully seated.

Binary/Trinary & Compressor:
Binary Switch: Terminate provided insulated female terminal (PN 23172-VUW) to the blue 16 AWG wire. Connect as shown.
Trinary Switch: Connect according to trinary switch wiring diagram.

WIRING HARNESS (232020) →

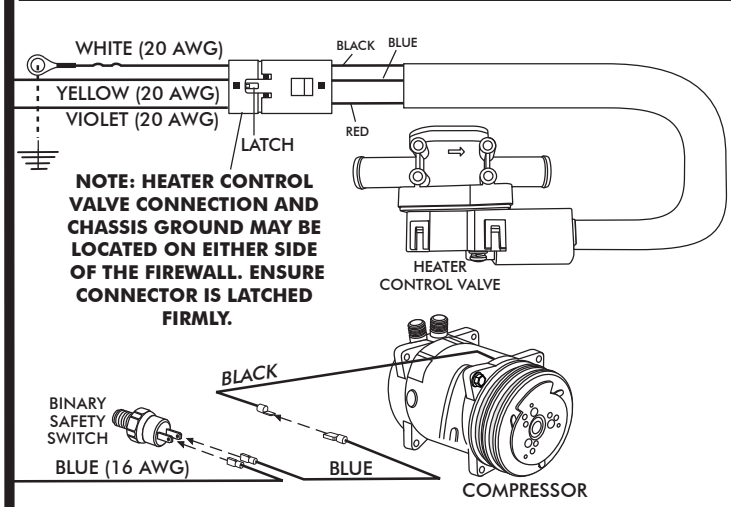

Battery Connections:
ECU Ground: Terminate provided ring terminal (PN 226110) to 20 AWG white wire from the 231505 wire assembly and install at battery.
ECU PWR: Terminate provided fuse assembly with black leads (PN 233012) to the 16 AWG red wire from the 231505 wire assembly. Install provided 10A Red Mini Fuse (PN 226118). Install at battery.
Blower Speed Controller (BSC) Ground: Terminate provided ring terminal (PN 226111) to 12 AWG white wire from the 232020 wire assembly and install at battery.
Blower Speed Controller (BSC) PWR: Terminate provided fuse assembly with orange leads (PN 233008) to the 12 AWG orange wire from the 232020 wire assembly. Install provided 30A Green ATO/ATC Fuse (PN 226125). Install at battery.

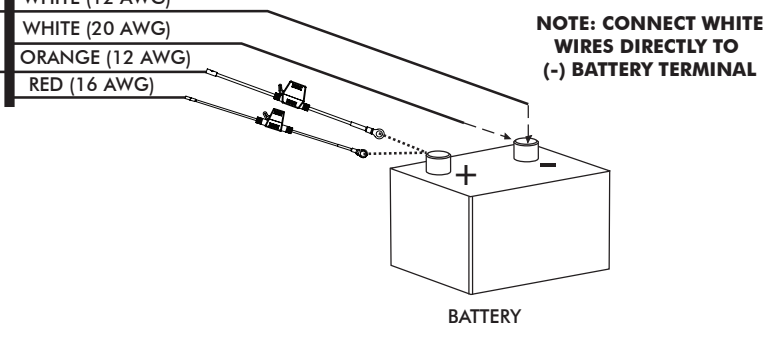



www.vintageair.com

Operation of Controls

On Gen IV or Gen 5 systems with three lever/knob controls, the temperature control toggles between heat and A/C operations. To activate A/C, move the temperature lever/knob all the way to cold and then back it off to the desired vent temperature. For heat operation, move the temperature lever/knob all the way to hot and then adjust to the desired vent temperature. The blower will momentarily change speed, each time you toggle between operations, to indicate the change.

Blower Speed

This lever/knob controls blower speed, from OFF to HI.

Mode Control

This lever/knob controls the mode positions, from DASH to FLOOR to DEFROST, with a blend in between.

Temperature Control

This lever/knob controls the temperature, from HOT to COLD.

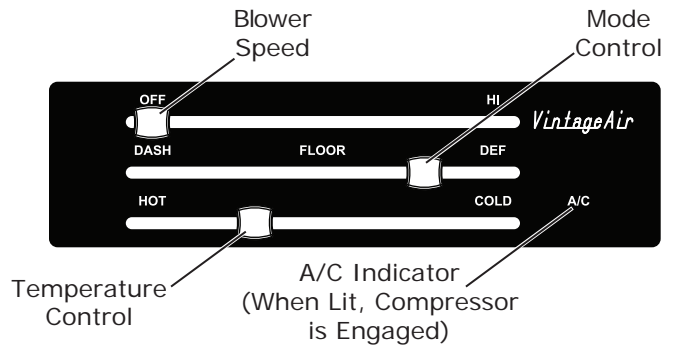

A/C Operation

Blower Speed

Adjust to desired speed.

Mode Control

Adjust to desired mode position (DASH position recommended).

Temperature Control

For A/C operation, adjust to coldest position to engage compressor (Adjust between HOT and COLD to reach desired temperature).



Heat Operation

Blower Speed

Adjust to desired speed.

Mode Control

Adjust to desired mode position (FLOOR position recommended).

Temperature Control

For maximum heating, adjust to hottest position (Adjust between HOT and COLD to reach desired temperature).

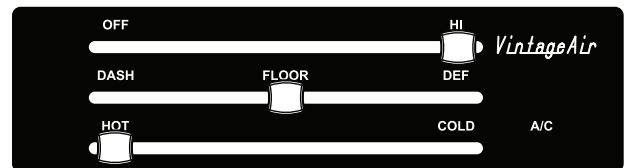

Defrost/De-fog Operation

Blower Speed

Adjust to desired speed.

Temperature Control

Adjust to desired temperature.

Mode Control

Adjust to DEFROST position for maximum defrost, or between FLOOR and DEFROST positions for a bi-level blend (Compressor is automatically engaged).





www.vintageair.com

Troubleshooting Guide

This printed troubleshooting guide is our basic guide that covers common installation problems. To see our advanced diagnostics and troubleshooting guide, please refer to the following page for instructions on how to download the complete guide.

WARNING: While troubleshooting the system, never probe connector terminals from the front mating side, only back probe.

WARNING: While troubleshooting the system, never use automotive check lights.

| Symptom | Condition | Checks | Actions | Notes |
|--|--|--|--|--|
| 1. Blower stays on high speed with ignition on. | No other functions work. | Check for damaged pins or wires in the control panel wire assembly and mating header at ECU. | If found damaged, replace wire assembly or ECU. | If fuse continues to blow, there is a serious problem in the wiring. Check all wiring and ensure the wire is not damaged and shorting out along its route. |
| | All other functions work. | Check for a bad ECU GND. Check for damaged pins or wires in the control panel wire assembly and mating header at ECU. Check if Blower power fuse is blown. Check for a bad ECU GND. | If found damaged, replace wire assembly or ECU. Replace fuse. Repair connection. | |
| 2. Compressor will not turn on (All other functions work). | System is not charged. | System must be charged for compressor to engage. | Charge system. | Danger: Never bypass safety switch with engine running. Serious injury can result. |
| | System is charged. | Check for faulty A/C potentiometer or associated wiring (not applicable to 3-pot controls). | Check continuity to ground on white control head wire. Check for 5V on red control head wire. | To check for proper pot function, check voltage at white/red wire. Voltage should be between 0V and 5V, and will vary with pot lever position. |
| | | Check for disconnected or faulty thermistor. | Check 2-pin connector at ECU housing. | Disconnected or faulty thermistor will cause compressor to be disabled. |
| 3. Compressor will not turn off (All other functions work). | Compressor will not turn off (All other functions work). | Check for faulty A/C potentiometer or associated wiring. | Repair or replace pot/control wiring. | Red wire at A/C pot should have approximately 5V with ignition on. White wire will have continuity to chassis ground. White/Red wire should vary between 0V and 5V when lever is moved up or down. |
| | | Check for faulty A/C relay. | Replace relay. | |



www.vintageair.com

Troubleshooting Guide (Cont.)

| Symptom | Condition | Checks | Actions | Notes |
|---|--|--|---|--|
| 4. System will not turn on, or runs intermittently. | Works when engine is not running; shuts off when engine is started | Noise interference from either ignition or alternator. | Install capacitors on ignition coil and alternator. Ensure good ground at all points. Relocate coil and associated wiring away from ECU and ECU wiring. Check for burned or loose plug wires. | Ignition noise (radiated or conducted) will cause the system to shut down due to high voltage spikes. If this is suspected, check with a quality oscilloscope. Spikes greater than 16V will shut down the ECU. Install a radio capacitor at the positive post of the ignition coil (see radio capacitor installation bulletin). A faulty alternator or worn out battery can also result in this condition. |
| | Will not turn on under any conditions. | Verify connections on power lead, ignition lead, and both white ground wires. Verify battery voltage is greater than 10 volts and less than 16 while engine is running. | Check for power at ECU, and confirm ignition is being applied to ECU properly. Verify proper meter function by checking the condition of a known good battery. | |
| 5. Loss of mode door function. | No mode change at all. | Check for damaged mode switch or potentiometer and associated wiring. | | |
| | Blower turns on and off rapidly. | Battery voltage is at least 12V. Battery voltage is less than 12V. | Ensure all system grounds and power connections are clean and tight. Charge battery. | System shuts off blower at 10V. Poor connections or weak battery can cause shutdown at up to 11V. |
| 7. Erratic functions of blower, mode, temp, etc. | | Check for damaged switch or pot and associated wiring. | Repair or replace. | |

Advanced Diagnostics and Troubleshooting Guide

If after referencing the Troubleshooting Guide, the issue is not resolved, move to The Advanced Diagnostics and Troubleshooting Guide that covers the following:

- ECU Diagnostics Codes
- 1. ECU Blink Sequence
- 2. Firmware Version Number
- 3. ECU Model Number
- 4. ECU Start-Up Blink Sequence
- 5. Diagnostic Codes
- Complete Advanced Troubleshooting Guidelines

Access the latest version of the Advanced Diagnostics and Troubleshooting Guide by scanning the following QR code on your mobile device:



You can also access the guide by typing the following address into your web browser:

https://www.vintageair.com/instructions_pdf/905000.pdf



www.vintageair.com

Packing List: Evaporator Kit (564415)

| No. | Qty. | Part No. | Description |
|-----|------|----------|--------------------------------------|
| 1. | 1 | 765200 | Gen 5 Magnum Max Module with 404 ECU |
| 2. | 1 | 784415 | Accessory Kit |

Checked By: _____
Packed By: _____
Date: _____

1



Gen 5 Magnum Max
Module with 404 ECU
765200

2

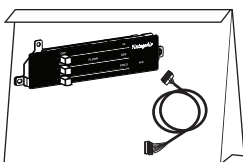
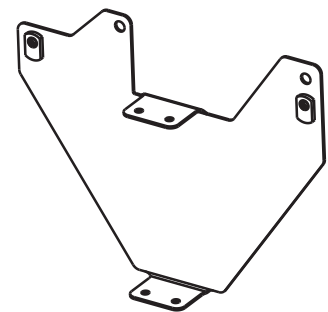
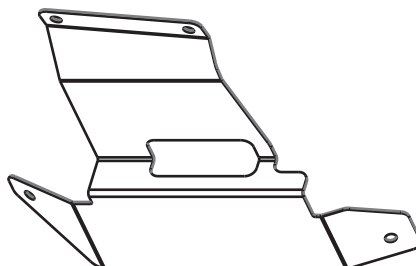
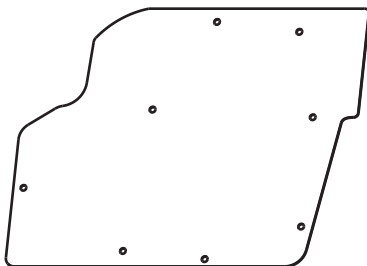

Accessory Kit
784415

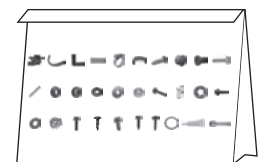
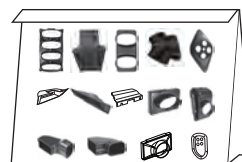
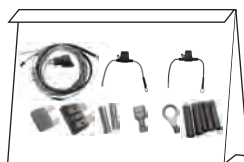

**NOTE: Images may not depict actual parts and quantities.
Refer to packing list for actual parts and quantities.**