



# 1982-87 Buick Regal

*with* Factory Air

Gen 5 Evaporator Kit

Magnum Max (564450)

Magnum (564451)

**Fits: 1986-87 Grand National**



18865 Goll St. San Antonio, TX 78266

Phone: 800-862-6658

Sales: [sales@vintageair.com](mailto:sales@vintageair.com)

Tech Support: [tech@vintageair.com](mailto:tech@vintageair.com)

[www.vintageair.com](http://www.vintageair.com)



www.vintageair.com

# Table of Contents

Cover.....	1
Table of Contents.....	2
Packing List/Parts Disclaimer.....	3
Information Page.....	4
Wiring Notice.....	5
Engine Compartment Disassembly.....	6-7
Condenser Assembly and Installation, Compressor and Brackets, Passenger Compartment.....	8
Passenger Compartment (Cont.).....	9-11
Firewall Modification & Insulation.....	12-13
Dash Support Bracket Modification.....	14
Dash Louver Adapter Preparation.....	15-16
Lubricating O-rings, Properly Seated O-ring Land.....	17
Evaporator Preparation.....	18-19
Evaporator Installation.....	20-21
Wiring Installation.....	22-23
Defrost Duct and Dash Installation.....	24
Passenger Compartment Wiring, Control Panel Installation, Inner Fender Reinstallation.....	25
Firewall Cover Boot Plate Installation.....	26
A/C Hose Installation.....	27-28
Water Deflector Installation.....	29
Heater Hose & Heater Control Valve Installation.....	30-31
Engine Compartment Wiring.....	32-34
Drain Hose Installation, Courtesy Lamp Relocation (If Equipped).....	35
OEM ECU Relocation (Magnum Max Only).....	36
Glove Box Modification and Installation (Style 1), Glove Box Modification and Installation (Style 2).....	37-38
Final Steps: Installation Check.....	39
Final Steps: Completing the Install.....	40
Duct Hose Routing.....	41
Quality Crimp Guideline.....	42
Gen 5 Wiring Diagram.....	43
Gen 5 Wiring Connection Instruction.....	44
Operation of Controls.....	45
Troubleshooting Guide.....	46
Troubleshooting Guide (Cont.), Advanced Diagnostics and Troubleshooting Guide.....	47
Packing List.....	48



www.vintageair.com

## Packing List: Evaporator Kit (564450)

No.	Qty.	Part No.	Description
1.	1	765200	Gen 5 Magnum Max Module
2.	1	784450	Accessory Kit

\*\* Before beginning installation, open all packages and check contents of shipment. Please report any shortages directly to Vintage Air within 15 days. After 15 days, Vintage Air will not be responsible for missing or damaged items.



Gen 5 Magnum Max  
Module  
765200

## Packing List: Evaporator Kit (564451)

No.	Qty.	Part No.	Description
1.	1	765100	Gen 5 Magnum Module
2.	1	784450	Accessory Kit

\*\* Before beginning installation, open all packages and check contents of shipment. Please report any shortages directly to Vintage Air within 15 days. After 15 days, Vintage Air will not be responsible for missing or damaged items.



Gen 5 Magnum  
Module  
765100

2



Accessory Kit  
784450

NOTE: Images may not depict actual parts and quantities.  
Refer to packing list for actual parts and quantities.



www.vintageair.com

## Important Notice—Please Read

*For Maximum System Performance, Vintage Air Recommends the Following:*

**NOTE:** Vintage Air systems are designed to operate with R134a refrigerant only. Use of any other refrigerant could damage your A/C system and/or vehicle, and possibly cause a fire, in addition to potentially voiding the warranties of the A/C system and its components.

### Refrigerant Capacities:

**Vintage Air System:** 1.8 lbs. (28.8 oz.) or 816 grams of **R134a**, charged by weight with a quality charging station or scale. **NOTE: Use of the proper type and amount of refrigerant is critical to system operation and performance.**

**Other Systems:** Consult manufacturer's guidelines.

### Lubricant Capacities:

**New Vintage Air-Supplied Sanden Compressor:** No additional oil needed (Compressor is shipped with proper oil charge).

**All Other Compressors:** Consult manufacturer (Some compressors are shipped dry and will need oil added).

### Safety Switches

Your Vintage Air system is equipped with a binary pressure safety switch. A binary switch disengages the compressor clutch in cases of extreme low pressure conditions (refrigerant loss) or excessively high head pressure (406 PSI) to prevent compressor damage or hose rupture. A trinary switch combines Hi/Lo pressure protection with an electric fan operation signal at 254 PSI, and should be substituted for use with electric fans. Compressor safety switches are extremely important since an A/C system relies on refrigerant to circulate lubricant.

### Service Info:

**Protect Your Investment:** Prior to assembly, it is critical that the compressor, evaporator, A/C hoses and fittings, hardlines, condenser and receiver/drier remain capped. Removing caps prior to assembly will allow moisture, insects and debris into the components, possibly leading to reduced performance and/or premature failure of your A/C system. This is especially important with the receiver/drier.

Additionally, when caps are removed for assembly, **BE CAREFUL!** Some components are shipped under pressure with dry nitrogen.

**Evacuate the System for 35-45 Minutes:** Ensure that system components (Drier, compressor, evaporator and condenser) are at a temperature of at least 85°F. On a cool day, the components can be heated with a heat gun **or** by running the engine with the heater on before evacuating. Leak check and charge to specifications.

### Bolts Passing Through Cowl and/or Firewall:

To ensure a watertight seal between the passenger compartment and the vehicle exterior, for all bolts passing through the cowl and/or firewall, Vintage Air recommends coating the threads with silicone prior to installation.

### Heater Hose (not included with this kit):

Heater hose may be purchased from Vintage Air (Part#31800-VUD) or your local parts retailer. Routing and required length will vary based on installer preference.



www.vintageair.com

## Important Wiring Notice—Please Read

*Some vehicles may have had some or all of their radio interference capacitors removed. There should be a capacitor found at each of the following locations:*

- 1. On the positive terminal of the ignition coil.**
- 2. If there is a generator, on the armature terminal of the generator.**
- 3. If there is a generator, on the battery terminal of the voltage regulator.**

Most alternators have a capacitor installed internally to eliminate what is called “whining” as the engine is revved. If whining is heard in the radio, or just to be extra cautious, a radio interference capacitor can be added to the battery terminal of the alternator.

It is also important that the battery lead is in good shape and that the ground leads are not compromised. There should be a heavy ground from the battery to the engine block, and additional grounds to the body and chassis.

If these precautions are not observed, it is possible for voltage spikes to be present on the battery leads. These spikes come from ignition systems and charging systems, and from switching some of the vehicle’s other systems on and off. Modern computer-operated equipment can be sensitive to voltage spikes on the power leads, which can cause unexpected resets, strange behavior and/or permanent damage.

Vintage Air strives to harden our products against these types of electrical noise, but there is a point where a vehicle’s electrical system can be degraded so much that nothing can help.

Radio interference capacitors should be available at most auto and truck parts suppliers. They typically are cylindrical in shape, a little over an inch long and a little over a half-inch in diameter, and they have a single lead coming from one end of the cylinder with a terminal on the end of the wire, as well as a mounting clip which is screwed into a good ground on the vehicle. The specific value of the capacitance is not too significant in comparison to ignition capacitors that are matched with the coil to reduce pitting of the points.

- Care must be taken, when installing the compressor lead, not to short it to ground. The compressor lead must not be connected to a condenser fan or to any other auxiliary device. Shorting to ground or connecting to a condenser fan or any other auxiliary device may damage wiring or the compressor relay, and/or cause a malfunction.
- When installing ground leads on Gen 5 systems, the blower control ground and ECU ground must be connected directly to the negative battery post.
- For proper system operation, the heater control valve must be connected to the ECU.



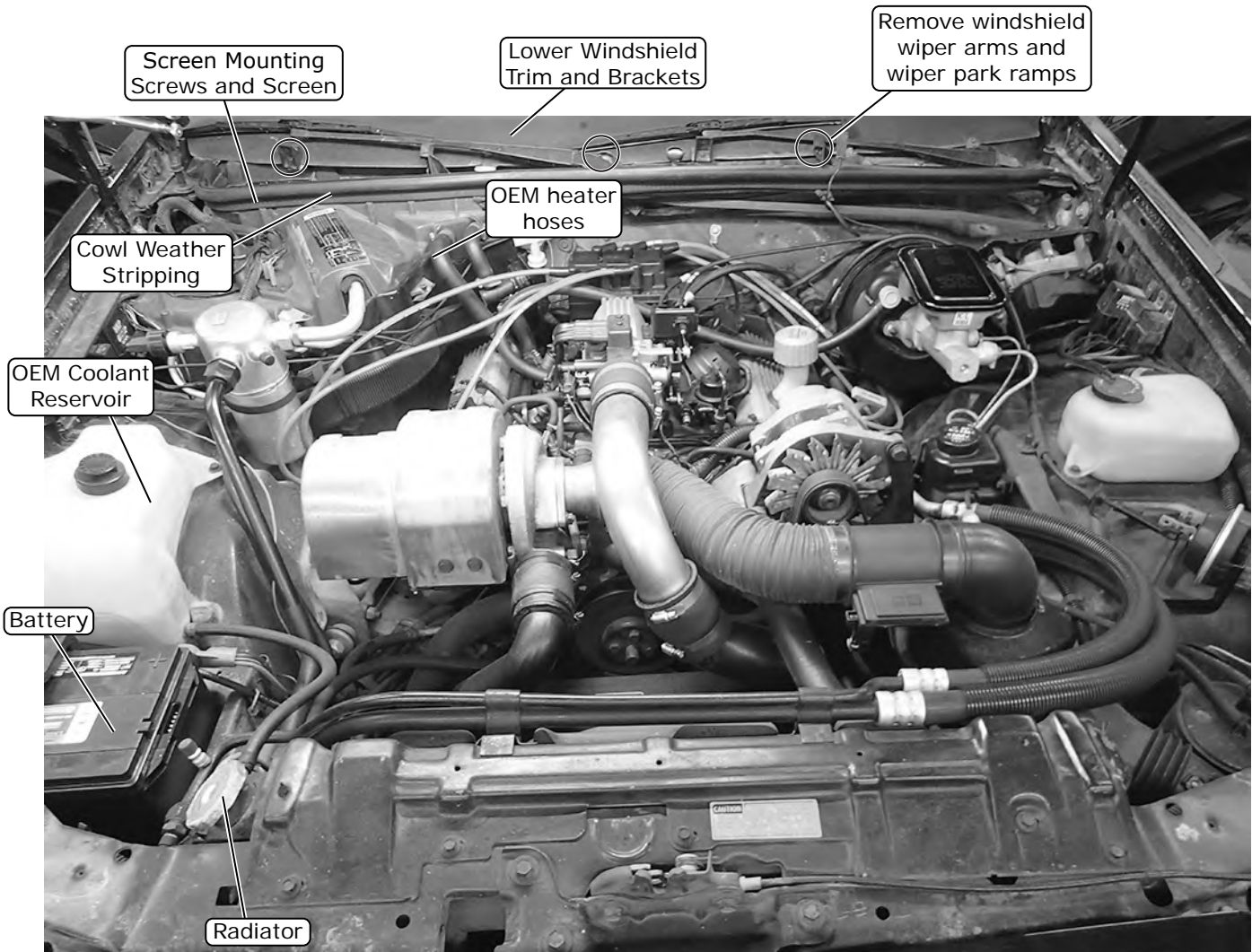
www.vintageair.com

## Engine Compartment Disassembly

**NOTE:** Before starting the installation, check the function of the vehicle (horn, lights, etc.) for proper operation, and study the instructions, illustrations, photos & diagrams.

**Perform the following:**

1. Disconnect the battery (See Photo 1, below).
2. Evacuate the A/C system (if necessary).
3. Jack up the front of the vehicle and support it with jack stands.
4. Remove the passenger-side wheel.
5. Drain the radiator (See Photo 1, below).
6. Remove the OEM heater hoses (See Photo 1, below).
7. Remove the OEM coolant reservoir and any other components attached to the passenger-side inner fender.
8. Remove the windshield wiper arms and wiper park ramps (See Photo 1, below).
9. Remove the lower windshield trim and brackets (See Photo 1, below).
10. Remove the cowl weather stripping (See Photo 1, below).
11. Remove the screen mounting screws and screen (See Photo 1, below).



**Photo 1**



www.vintageair.com

## Engine Compartment Disassembly (Cont.)

12. Disconnect all A/C hoses, vacuum and electrical connections from the OEM evaporator (See Photo 2, below).
13. Disconnect the A/C hoses from the OEM compressor, condenser and evaporator (See Photos 3, 4 and 5, below) (discard).
14. Remove the inner fender mounting hardware, then remove the inner fender. **NOTE: This is necessary to access the evaporator mounting bolts and provide space to remove the OEM evaporator module.**
15. Remove all of the mounting hardware securing the OEM evaporator to the firewall.
16. Remove the ground wire behind the coil packs (See Photo 6, below).

Disconnect electrical connections from OEM evaporator



Photo 2

Disconnect OEM evaporator lines

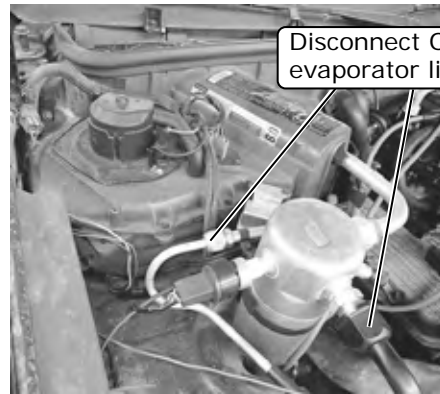


Photo 3

Disconnect A/C hoses from OEM condenser

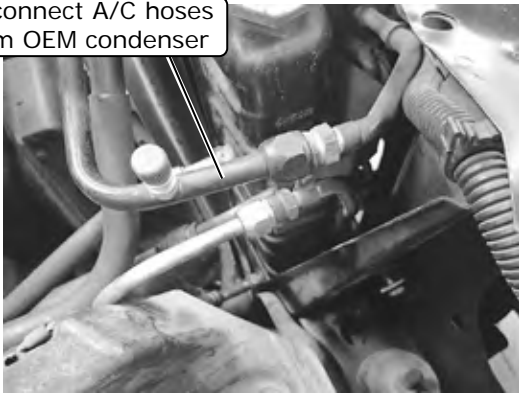


Photo 4

Disconnect A/C hoses from OEM compressor

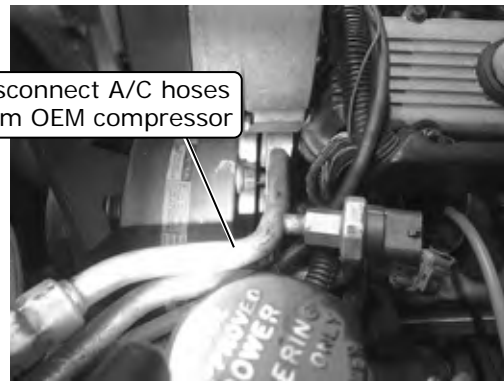


Photo 5

Coil Packs



Remove ground wire behind coil packs

Photo 6



www.vintageair.com

## Condenser Assembly and Installation

1. Refer to separate instructions included with the condenser kit to install the condenser.
2. Binary switch installation (Refer to condenser instructions).

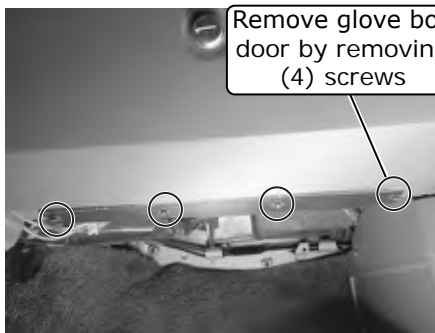
## Compressor and Brackets

1. Refer to separate instructions included with the bracket kit to install the compressor bracket.

## Passenger Compartment Disassembly

**NOTE:** Removing the front seats will provide extra room for the passenger compartment disassembly process. The removal of the dash is required to remove the OEM duct work from the vehicle. Refer to the vehicle shop manual for more detailed information. Retain OEM bolts, washers and nuts, as some hardware will be reused.

1. Remove the glove box door by removing (4) screws (See Photo 1, below).
2. Remove the control panel/radio bezel by removing (4) screws (See Photo 2, below).
3. Remove the control panel by removing (4) mounting screws (See Photo 3, below) (retain screws).
4. Disconnect the cables, plugs and vacuum lines, then remove the control panel.
5. Remove the radio.
6. Release any clips holding wires to the OEM evaporator.
7. Remove (2) evaporator/duct work mounting screws (See Photo 4, below).
8. Remove the ground wire mounting bolt on the passenger side, above the OEM ECU (See Photo 5, below).
9. Remove the OEM evaporator from the vehicle through the engine compartment.



Remove glove box door by removing (4) screws

**Photo 1**



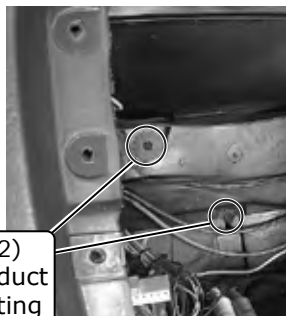
Remove control panel/radio bezel by removing (4) screws

**Photo 2**



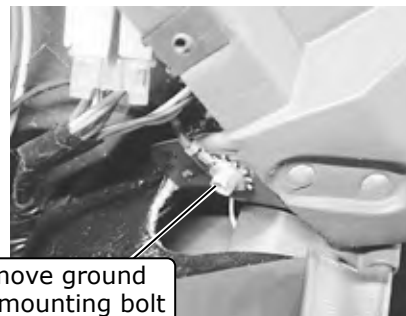
Remove control panel by removing (4) mounting screws

**Photo 3**



Remove (2) evaporator/duct work mounting screws

**Photo 4**



Remove ground wire mounting bolt on passenger side, above OEM ECU

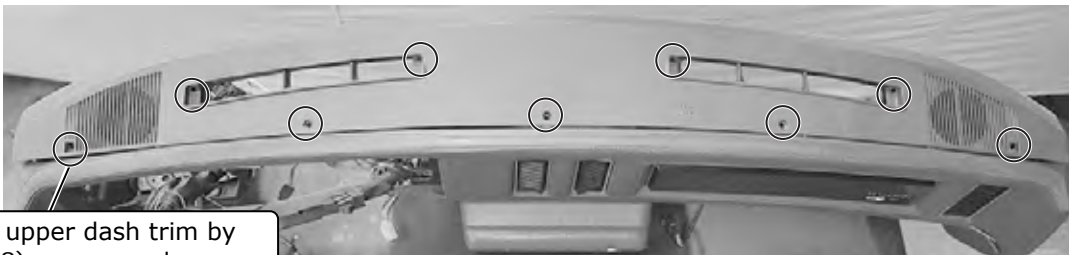
**Photo 5**



www.vintageair.com

## Passenger Compartment Disassembly (Cont.)

10. Remove the upper dash trim by removing (9) screws (See Photo 6, below), then remove the light sensor (if equipped).
11. Carefully remove the instrument cluster bezel (See Photo 7, below). **NOTE: The bezel is installed with push-in clips.**
12. Remove the dash pad by removing (6) screws (See Photo 8, below).
13. Remove (4) gauge mounting screws, then disconnect the speedometer cable and remove the gauges (See Photo 9, below).
14. Remove (3) headlight switch bracket screws, then unplug the switch and remove it (See Photo 10, below).



Remove upper dash trim by removing (9) screws and remove light sensor (if equipped)

Carefully remove instrument cluster bezel

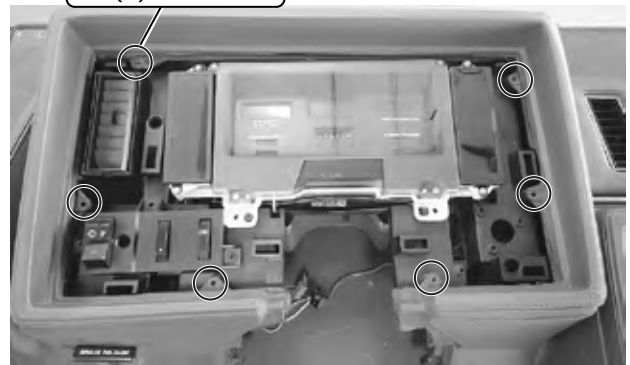
Remove dash pad by removing (6) screws

Photo 6



Remove (4) gauge mounting screws, then disconnect speedometer cable and remove gauges.

Photo 7



Remove (3) headlight switch bracket screws, then unplug switch and remove it

Photo 8

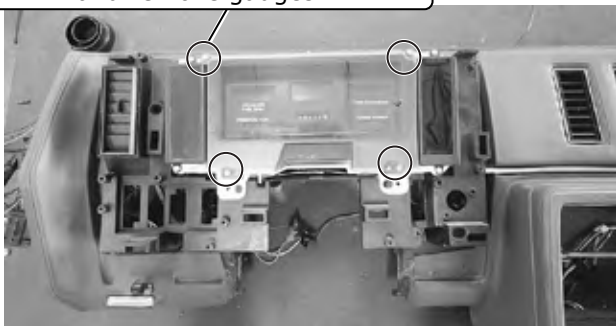


Photo 9

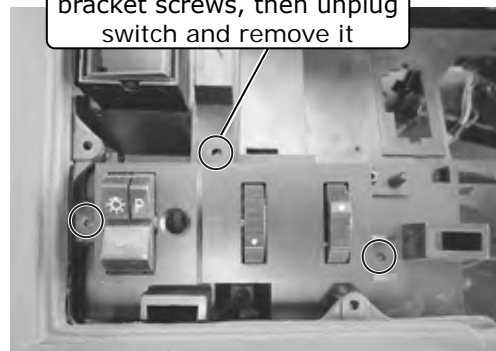


Photo 10



www.vintageair.com

## Passenger Compartment Disassembly (Cont.)

15. Remove the gauge cluster reinforcement by removing (7) screws (See Photo 11, below).
16. Remove the under-column louver cover by removing (4) screws (See Photo 12, below).
17. Drop the steering column by removing the (2) mounting nuts (See Photo 13, below).
18. Remove the under-column mounting bolt (See Photo 14, below).
19. Remove the driver-side under dash mounting nut (See Photo 15, below).
20. Remove the dash bracket support screw (See Photo 16, below). **NOTE: The dash support bracket screw is located in the control panel/radio area and can be accessed from under the dash.**

Remove gauge cluster reinforcement by removing (7) screws

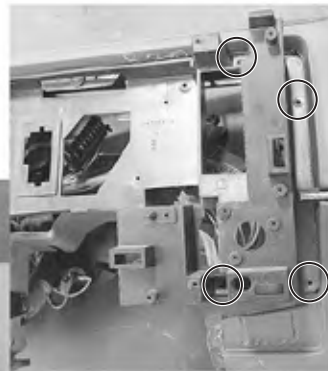
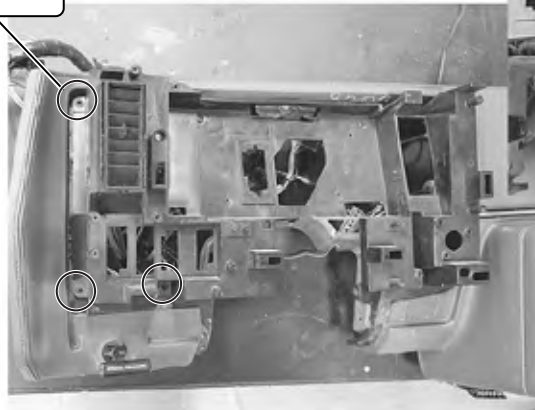


Photo 11

Remove under-column louver by removing (4) screws

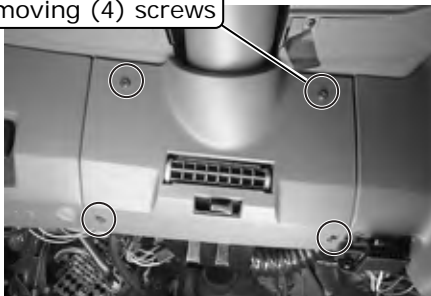


Photo 12

Remove (2) mounting nuts to drop steering column



Photo 13

Remove under-column mounting bolt



Photo 14

Remove driver-side under dash mounting nut



Photo 15

Remove dash bracket support screw



Photo 16



www.vintageair.com

## Passenger Compartment Disassembly (Final)

21. Unplug all wiring connections from the dash.
22. Disconnect the fuse panel from the engine and passenger compartment.
23. Remove (4) dash mounting screws (See Photos 17 and 18, below).
24. Carefully remove the dash from the vehicle.
25. Remove the OEM duct work by removing (4) mounting screws ((2) per defrost duct) (See Photo 19, below).



**Photo 17**



**Photo 18**



**Photo 19**



www.vintageair.com

## Firewall Modification & Insulation

**NOTE:** The firewall requires modification for the drain hose to be installed. For proper system operation, Vintage Air recommends using heat-blocking insulation in the area around the evaporator module (firewall, kick panel, inner cowl, firewall covers). Due to tight clearance for the evaporator module between the firewall and dash, Vintage Air recommends an insulation thickness of no more than 1/4". To ensure a watertight seal between the passenger compartment and the vehicle exterior, for all bolts passing through the firewall, Vintage Air recommends coating the threads with silicone prior to installation. The OEM insulation on the passenger side of the transmission tunnel should be changed to an 1/8" thickness to ease the installation of the evaporator assembly (See Photo 1, below).

Perform the following: (For Magnum Kit, proceed to Step 4, Page 11)

1. (Magnum Max Kit Only) Remove the metal tabs from the firewall opening (See Photos 2 and 3, below).
2. (Magnum Max Kit Only) Trim the OEM dash mounting bracket (See Photos 4, 5, 6, and 7, below). **NOTE:** To assure the dash mounting bracket has been modified enough to provide proper clearance, the evaporator module may need to be mocked up in the vehicle multiple times. While the evaporator module is in place, loosely install the dashboard and check the passenger-side mounting bracket for clearance. The passenger-side mounting bracket may also need to be modified for fitment (See Photos 8 and 9, below).

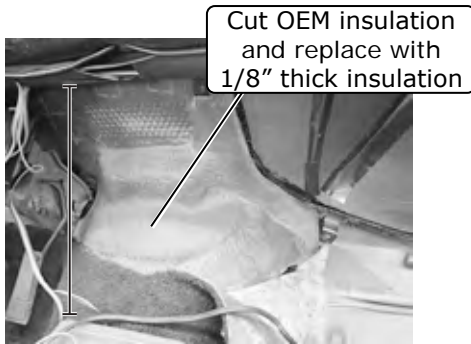


Photo 1

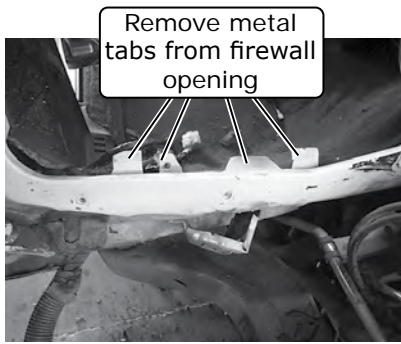


Photo 2



Photo 3



Photo 4



Photo 5

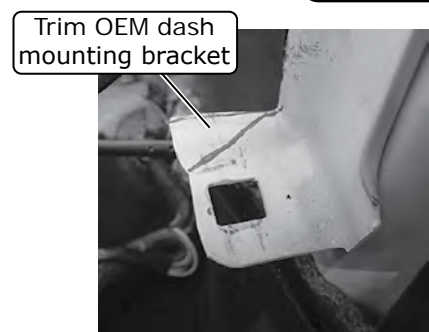


Photo 6



OEM Mounting Bracket Trimmed

Photo 7

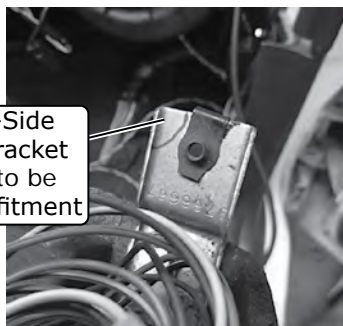


Photo 8



Passenger-Side Mounting Bracket Trimmed

Photo 9



www.vintageair.com

## Firewall Modification & Insulation (Cont.)

- Using the bead roll on the floor pan for reference, measure down 1/2" from the firewall (See Photo 10 , below). Mark and drill a 5/8" hole for the drain hose (See Photo 11, below). **NOTE: To ensure a tight fit for the drain hose, do not enlarge the drain hole more than 5/8".**
- Install heat-blocking insulation onto the firewall and firewall cover at this time (See Photos 12 and 13, below).

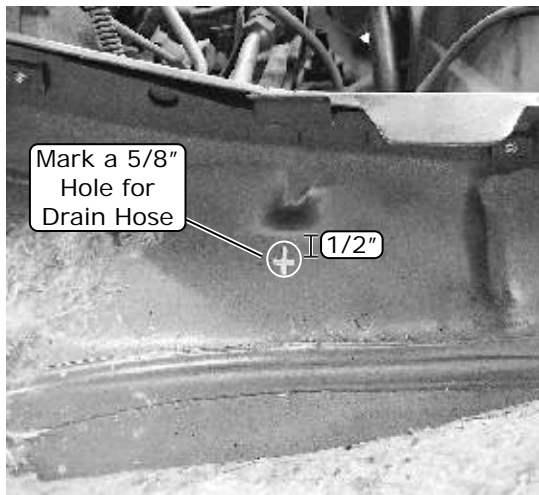


Photo 10

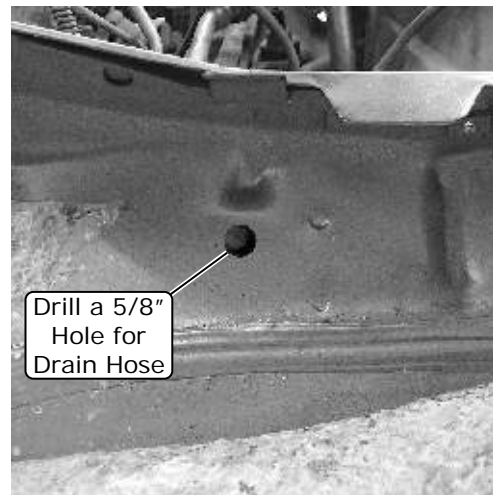


Photo 11

Install heat-blocking insulation onto firewall and firewall cover

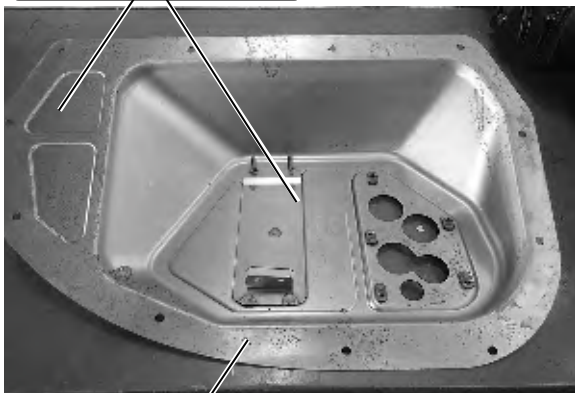


Photo 12

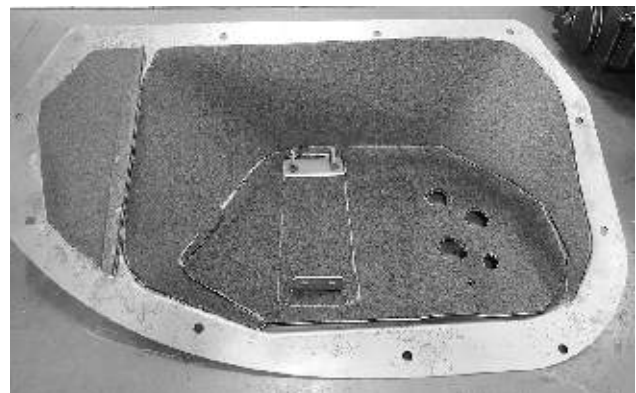


Photo 13



www.vintageair.com

## Dash Support Bracket Modification

**NOTE:** Begin with the modification shown in the following steps. Once the evaporator module is in place test fit the dashboard and check for clearance more modification may be needed before final installation.

1. Locate the dash support bracket rivet by the glove box door opening (See Photo 1, below). Use the measurements in Photo 1, below, then mark and remove the portion of the dash support bracket (See Photos 1 and 2, below).

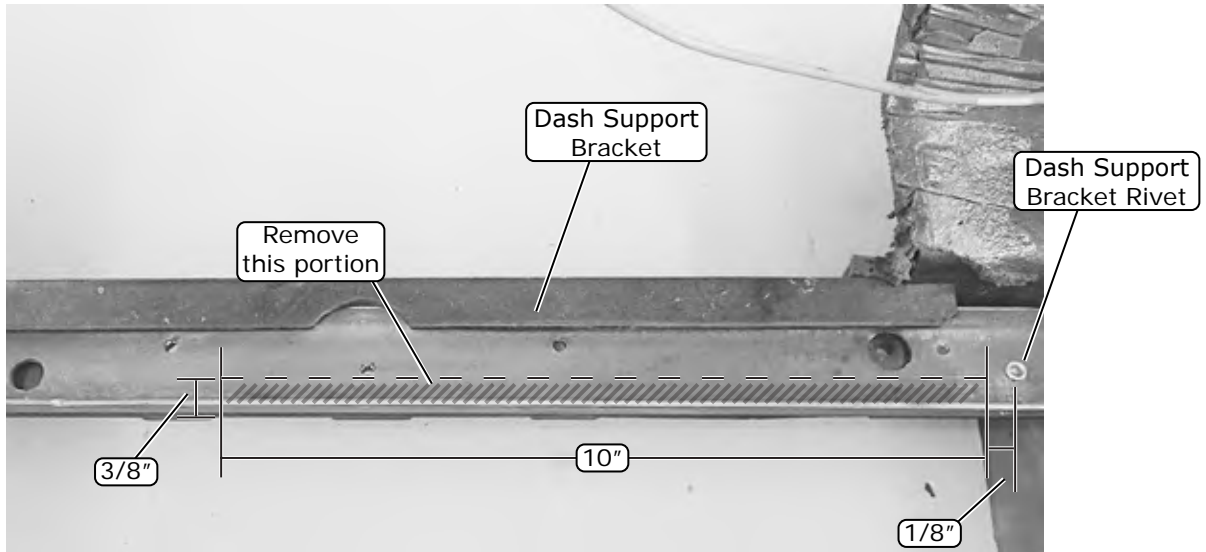
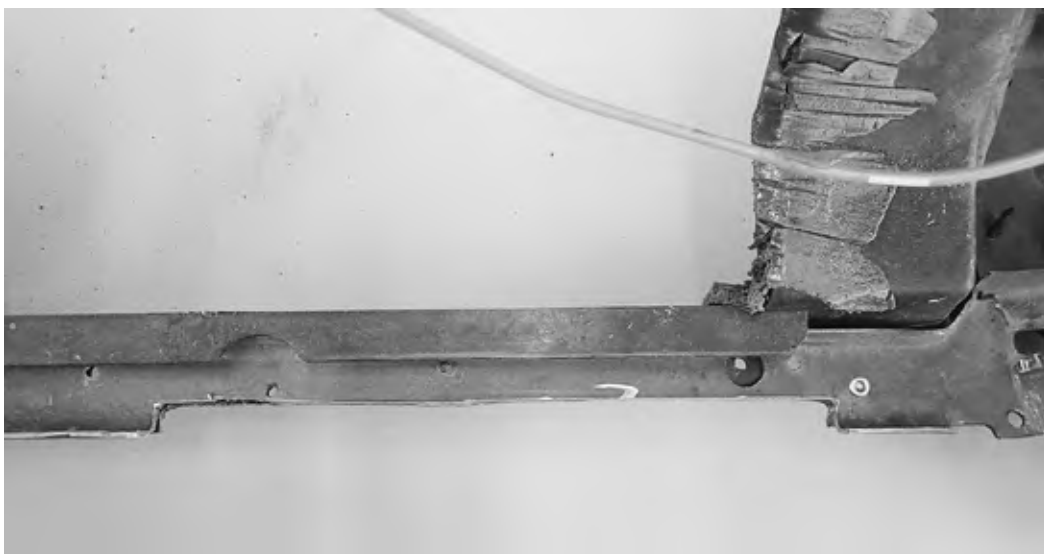


Photo 1



After Modification

Photo 2



www.vintageair.com

## Dash Louver Adapter Preparation

On a workbench, perform the following:

**NOTE:** If equipped, the twilight sentinel will have to be relocated as shown in Steps 2-4.

1. Remove the (3) OEM screws (retain) from the OEM center louver vent flange, then remove it from the dash (discard) (See Photo 1, below).
2. Place the center louver template onto the center louver hose adapter as shown in Photo 2, below. Mark and drill (2) 7/32" mounting holes into the center dash hose adapter (See Photo 2, below).
3. Remove the twilight sentinel mounting screw (retain screw) (See Photo 3, below), and install the #8 U-nut into the open side of the sentinel (See Photo 4, below).
4. Install the sentinel onto the center louver hose adapter using the factory mounting screw and a #8 x 3/4" countersunk screw with washer (See Photo 5, below).

Remove (3) OEM screws, then remove OEM center louver vent flange from dash



Photo 1

Center Dash Hose Adapter 625033

Center Louver Template 649633

Mark and drill (2) 7/32" mounting holes into center dash hose adapter

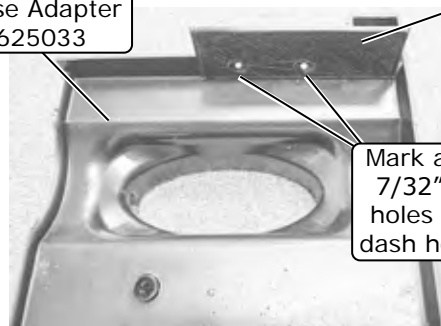


Photo 2

Remove twilight sentinel mounting screw

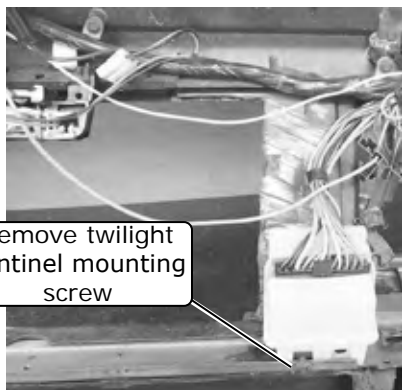


Photo 3

Install #8 U-nut into open side of sentinel

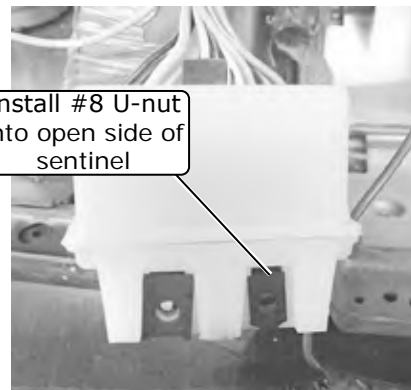


Photo 4

Factory Mounting Screw

#8 x 3/4" Countersunk Screw with Washer

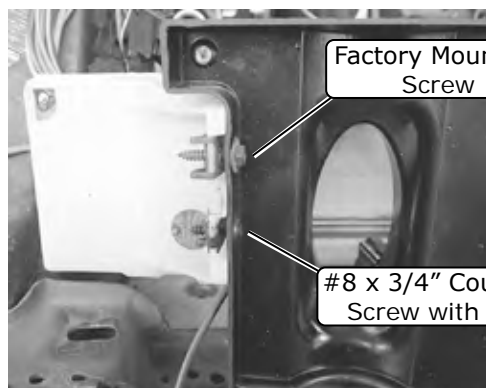


Photo 5



www.vintageair.com

# Dash Louver Adapter Preparation (Cont.)

5. Install the center dash hose adapter using the OEM hardware (See Photo 6, below).
6. Apply the foam strips onto the passenger-side dash hose adapter (See Photo 7, below). Install it into the passenger-side plenum (See Photo 8, below). **NOTE: Silicone may be used for an additional seal.**
7. Apply silicone to the mating surface of the driver-side dash hose adapter, and install it over the OEM louver housing (See Photos 9 and 10, below).
8. Apply silicone to the under dash louver housing, and install the hose adapter reducer (See Photos 11 and 12, below).

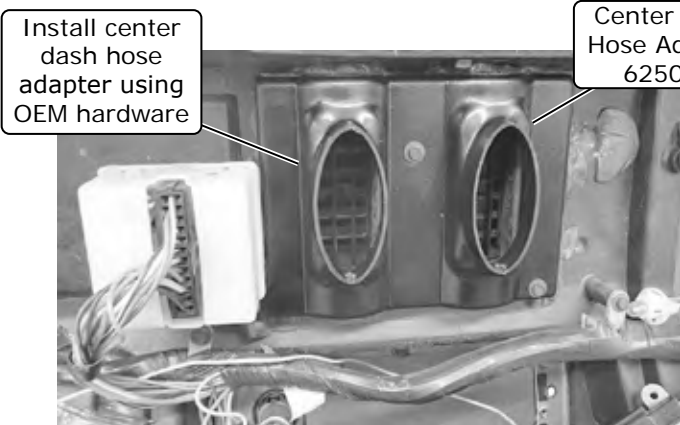


Photo 6

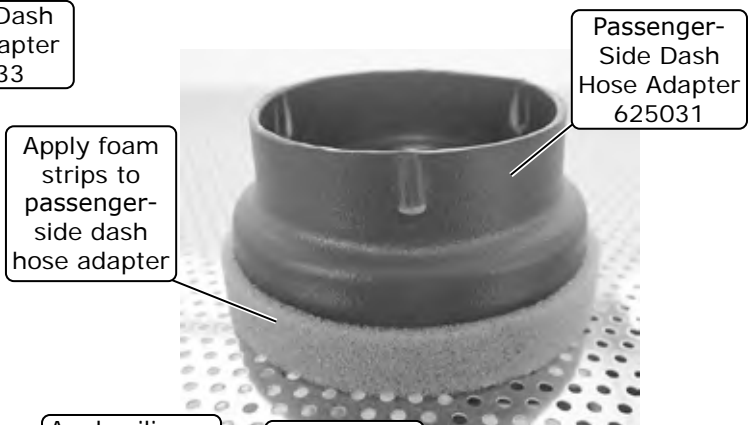


Photo 7

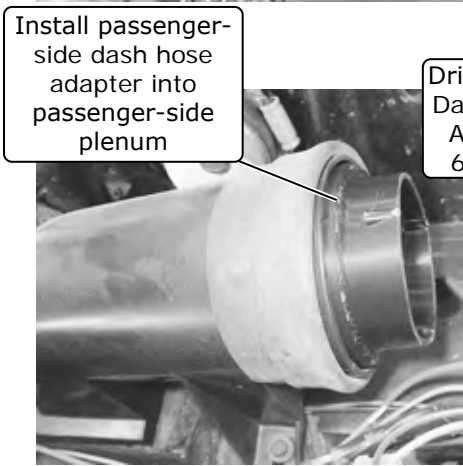


Photo 8

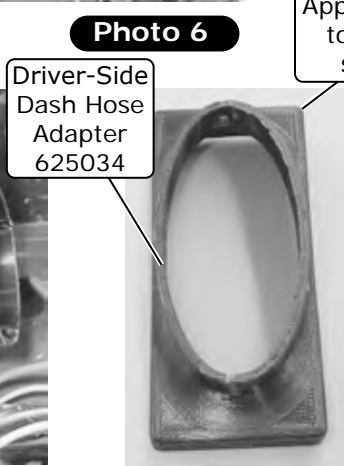


Photo 9

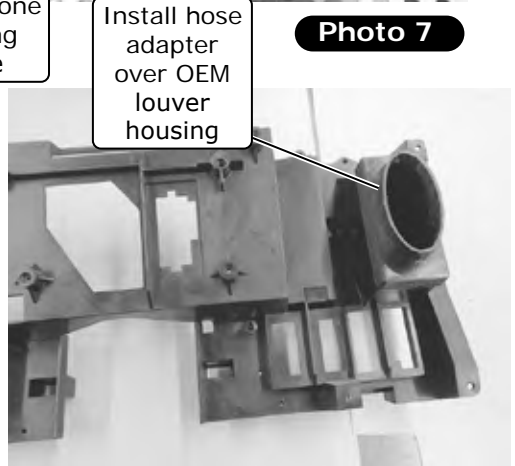


Photo 10

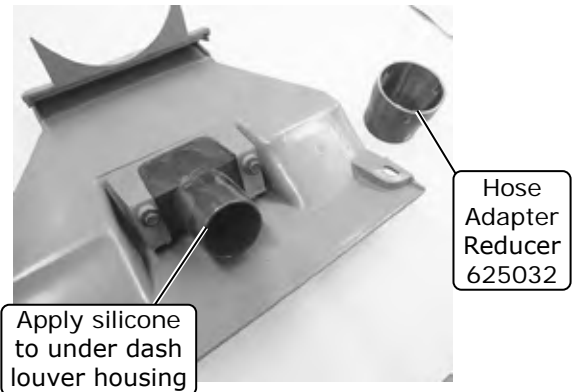


Photo 11

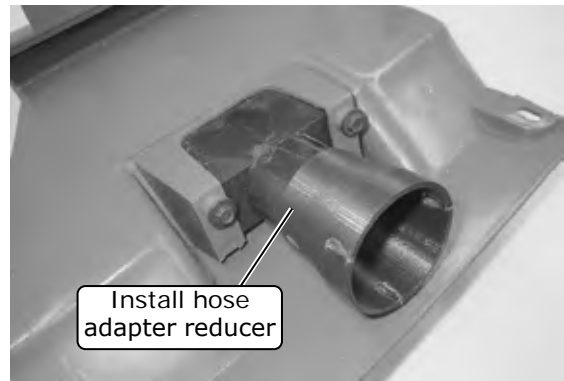
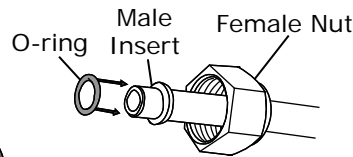
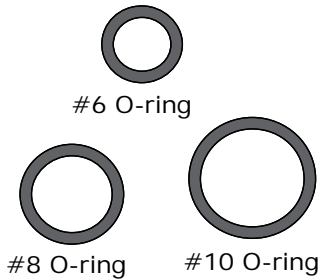


Photo 12

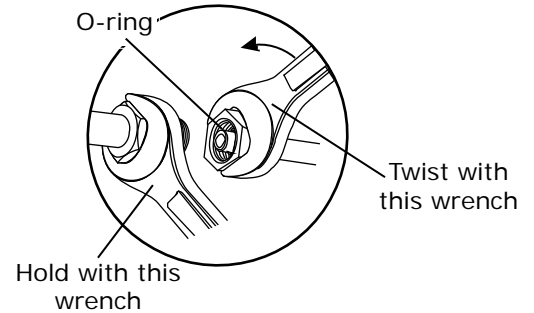
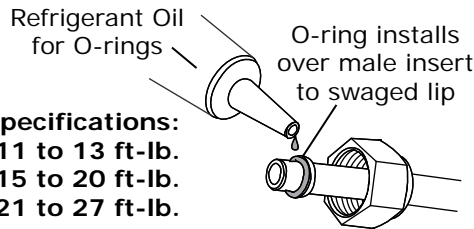


www.vintageair.com

## Lubricating O-rings



For a proper seal of fittings: Install supplied O-rings as shown and lubricate with refrigerant oil.



**NOTE: Standard torque specifications:**  
#6: 11 to 13 ft-lb.  
#8: 15 to 20 ft-lb.  
#10: 21 to 27 ft-lb.

## Properly Seated O-ring Land

When installing a hardline or A/C hose fitting onto the evaporator module, ensure the O-ring land is seated properly (See Photo 1, below). An improperly seated O-ring land (See Photo 2, below) can cause a leak. To properly install the fitting, slide the hardline or A/C hose nut back to expose the O-ring land and seat it onto the evaporator module fitting. Then, slide the hardline or A/C hose nut forward and thread it onto the evaporator module fitting, ensuring the O-ring land does not move or lift.

Properly Seated O-ring Land



Photo 1

Improperly Seated O-ring Land



Photo 2

**NOTE: Photos shown are for reference only. Fittings may vary depending on kit received.**



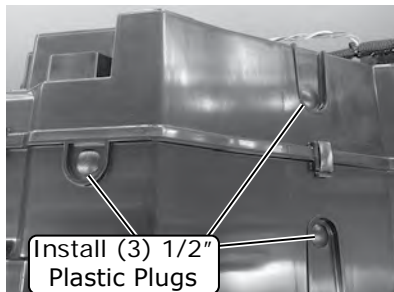
www.vintageair.com

## Evaporator Preparation

**NOTE:** Before fully tightening the hardlines, ensure the hardlines are aligned with the opening on the firewall cover plate as shown in Photo 8, below. Use a back up wrench when tightening fittings.

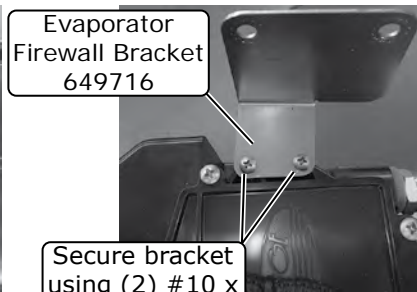
Perform the following on a workbench:

1. Install (3) 1/2" plastic plugs into the back of the evaporator module (See Photo 1, below). **NOTE:** These mounting provisions will not be used in this application.
2. Using (2) #10 x 5/8" screws, secure the evaporator firewall bracket onto the evaporator module (See Photo 2, below).
3. Using (4) spring clips, install the dash plenum onto the evaporator module as shown in Photos 3 and 4, below.
4. Using (2) spring clips, install the floor plenum onto the back of the evaporator module as shown in Photo 5, below.
5. Using (2) spring clips, install the defrost plenum onto the front of the evaporator module as shown in Photo 6, below.
6. With (2) properly lubricated #10 O-rings (See Lubricating O-rings, Page 17), loosely install the upper and lower heater hardlines (See Photo 7, below).
7. Place the evaporator module into the firewall cover and check the alignment of the heater hardlines (See Photo 8, below). Hardlines should be centered in the firewall cover openings. Once hardlines are centered, remove the firewall cover and tighten both hardlines.



Install (3) 1/2" Plastic Plugs

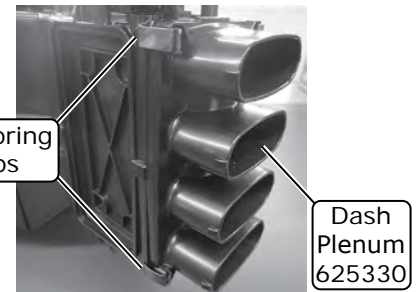
Photo 1



Evaporator Firewall Bracket 649716

Secure bracket using (2) #10 x 5/8" screws

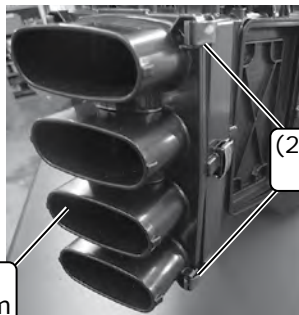
Photo 2



(2) Spring Clips

Dash Plenum 625330

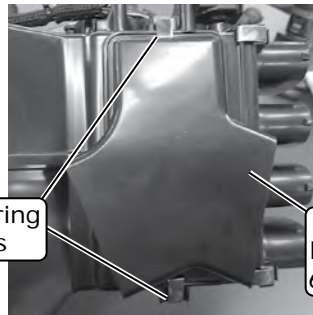
Photo 3



(2) Spring Clips

Dash Plenum 625330

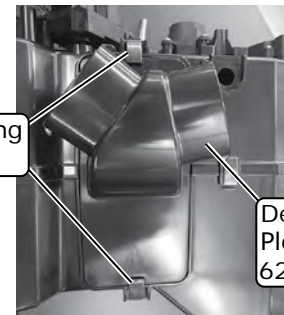
Photo 4



(2) Spring Clips

Floor Plenum 625338

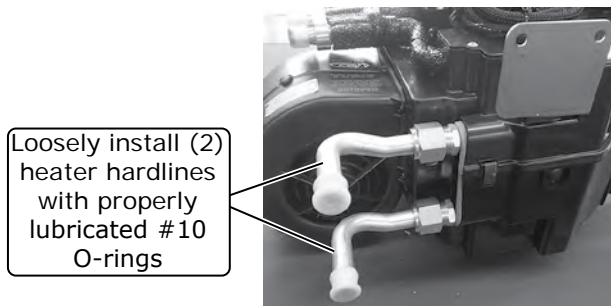
Photo 5



(2) Spring Clips

Defrost Plenum 625331

Photo 6



Loosely install (2) heater hardlines with properly lubricated #10 O-rings

Photo 7



Place evaporator module into firewall cover and center heater hardlines

Photo 8



www.vintageair.com

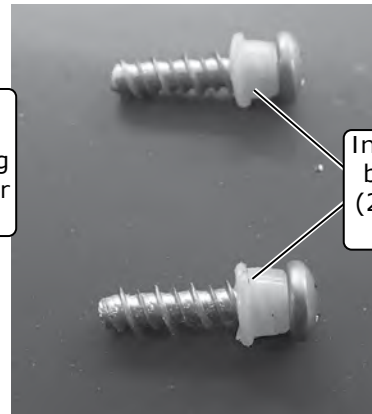
## Evaporator Preparation (Cont.)

8. Remove the (2) #10 x 5/8" screws (retain) securing the ECU to the evaporator module (See Photo 9, below), and let it hang in front of the module.
9. Install (2) nylon bushings onto (2) 8-18 x 5/8" screws, then reinstall them into the top of the evaporator module (See Photos 10 and 11, below). **NOTE: The nylon bushings will ease the reinstallation of the ECU when the evaporator module is fully installed into the vehicle, where there is limited access to the ECU mounting screws.**
10. Place the evaporator module assembly into the firewall cover, then secure the top mount with (2) 1/4-20 locknuts (See Photo 12, below).
11. Secure the firewall cover to the evaporator module lower mount using (2) #10 x 5/8" screws (removed in Step 8) (See Photo 13, below).



Remove (2) #10 x 5/8" screws (discard) securing ECU to evaporator module

Photo 9



Install (2) nylon bushings onto (2) 8-18 x 5/8" screws

Photo 10

Reinstall (2) 8-18 x 5/8" screws with nylon bushings into top of module

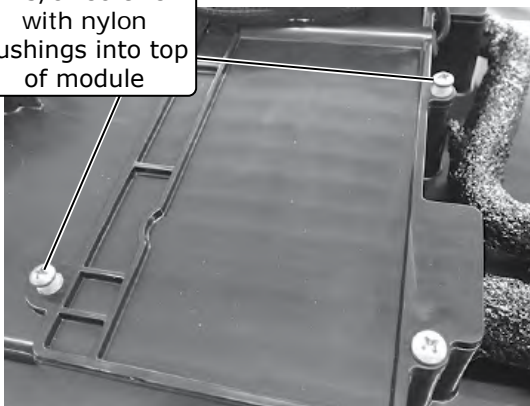
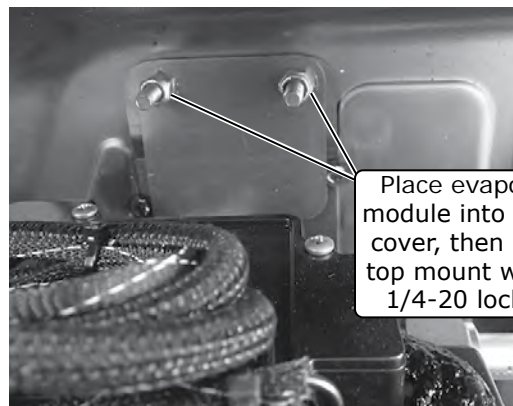
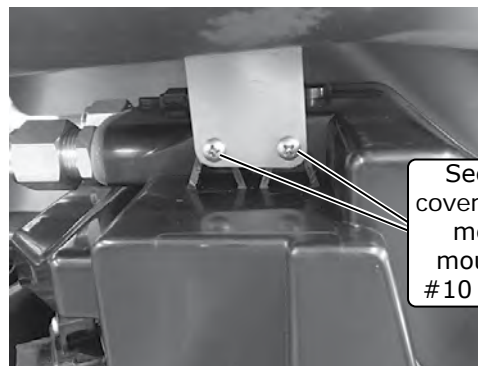


Photo 11



Place evaporator module into firewall cover, then secure top mount with (2) 1/4-20 locknuts

Photo 12



Secure firewall cover to evaporator module lower mount using (2) #10 x 5/8" screws

Photo 13



www.vintageair.com

## Evaporator Installation

**NOTE:** To ensure a watertight seal between the passenger compartment and the vehicle exterior, for all bolts passing through the firewall, Vintage Air recommends coating the threads with silicone prior to installation. To ensure proper drainage, it is very important that the evaporator is level, both left-right and fore-aft. Check for level on the flat portions of the module around the drain (See Photos 8 & 9, Page 16).

1. Remove the OEM dash support bracket by removing the (2) mounting bolts (retain hardware) (See Photo 1, below).
2. Apply silicone to the mating surface of the firewall cover (See Photo 2, below).
3. Install the evaporator assembly onto the firewall opening, and secure it using (11) M6.3 x 16mm hex head screws (See Photos 3 and 4, below). **NOTE: Do not overtighten the screws, as this will cause the firewall cover to warp.**
4. Install the ECU onto the 8-18 x 5/8" screws with nylon bushings (See Photo 5, below).
5. Install (2) 1/4-20 well nuts onto the evaporator module (See Photo 6, below).



Remove OEM dash support bracket by removing (2) mounting bolts

Photo 1

Apply silicone to mating surface of firewall cover

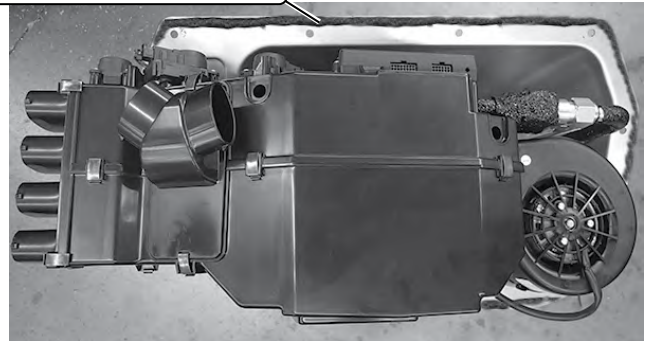


Photo 2

Install evaporator assembly into firewall opening

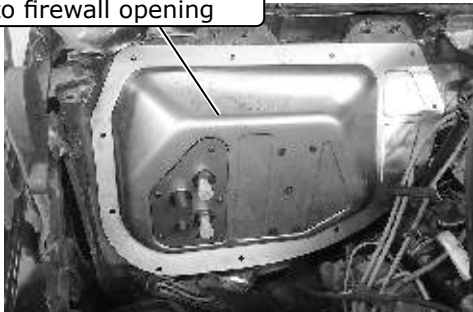


Photo 3

Secure using (11) M6.3 x 16mm hex head screws

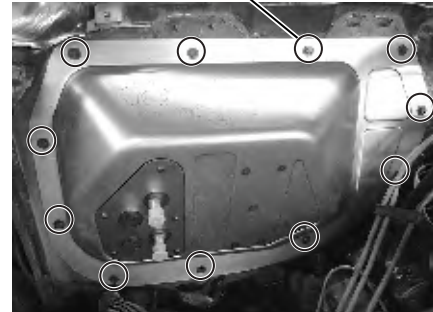


Photo 4

Install ECU onto 8-18 x 5/8" screws with nylon bushings



Photo 5

Install (2) 1/4-20 well nuts onto evaporator module

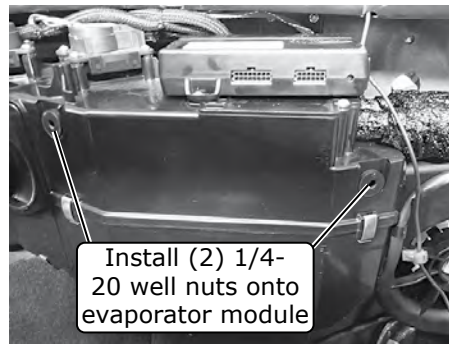


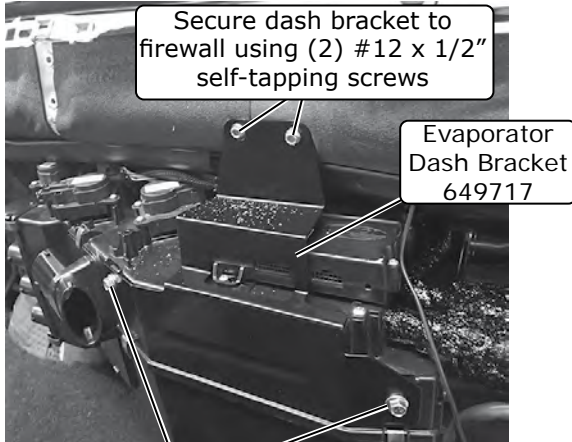
Photo 6



www.vintageair.com

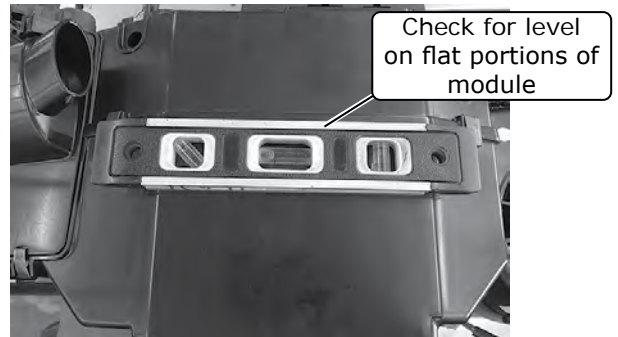
## Evaporator Installation (Cont.)

6. Install the evaporator dash bracket using (2) 1/4-20 x 1" serrated flange bolts (See Photo 7, below).
7. Level the evaporator module, both left-right and fore-aft. Check for level on the flat portions of the module around the drain (See Photos 8 & 9, below).
8. Using (2) #12 x 1/2" self-tapping screws, secure the evaporator dash bracket to the firewall (See Photo 7, below).
9. Loosely install the new dash support brace bracket using the OEM hardware (See Photo 10, below).
10. Install a 1/4-20 U-nut onto the dash support brace bracket (See Photo 11, below).

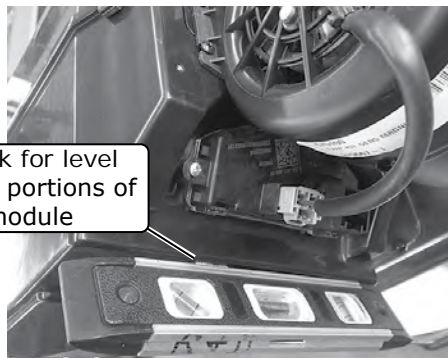


**Photo 7**

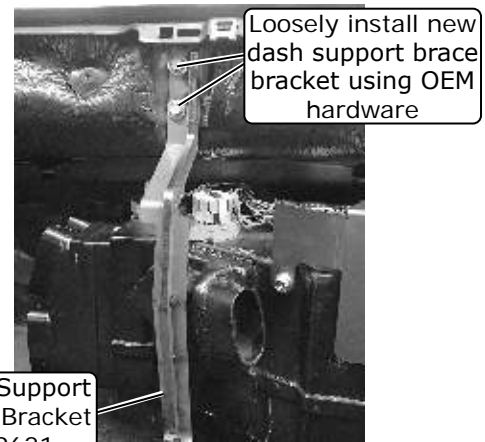
Install evaporator dash bracket using (2) 1/4-20 x 1" serrated flange bolts



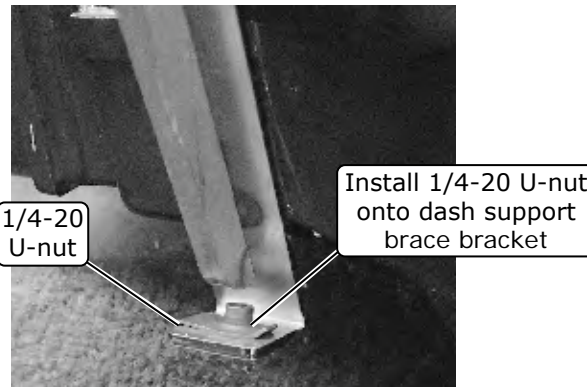
**Photo 8**



**Photo 9**



**Photo 10**



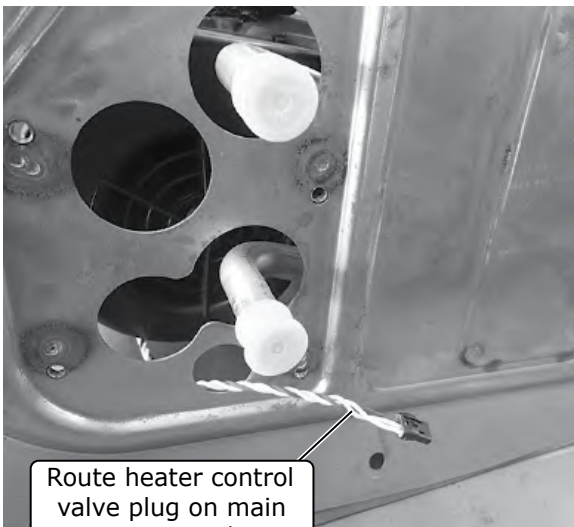
**Photo 11**



www.vintageair.com

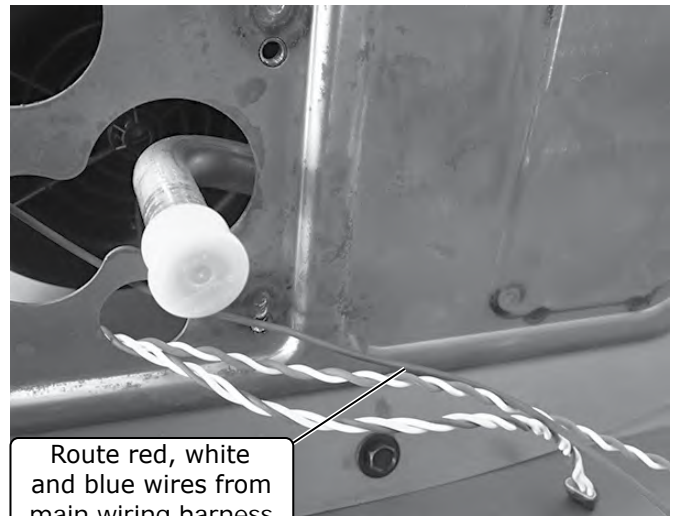
## Wiring Installation

1. From the passenger compartment, route the heater control valve plug on the main wiring harness (white/yellow/purple) through the firewall cover (See Photo 1, below).
2. Route the red, white and blue wires from the main wiring harness through the firewall cover (See Photo 2, below). **NOTE: Leave approximately 27" of wiring between the relay and the firewall boot. This allows enough wiring to secure the relay to the mounting position.**
3. Route the heavy gauge orange and white wires through the firewall cover (See Photo 3, below).
4. Connect the blower speed controller plug into the main wiring harness plug (orange and green wires) (See Photo 4, below).



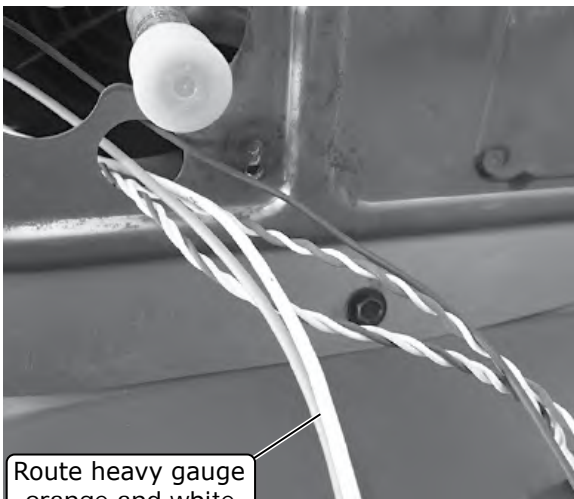
Route heater control valve plug on main wiring harness (white, yellow and purple) through firewall cover

Photo 1



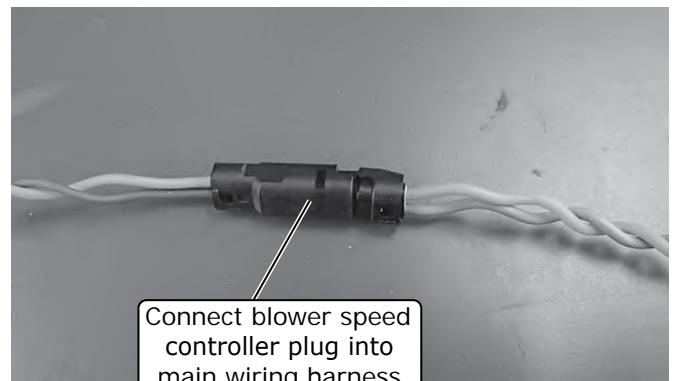
Route red, white and blue wires from main wiring harness through firewall cover

Photo 2



Route heavy gauge orange and white wires through firewall cover

Photo 3



Connect blower speed controller plug into main wiring harness plug

Photo 4

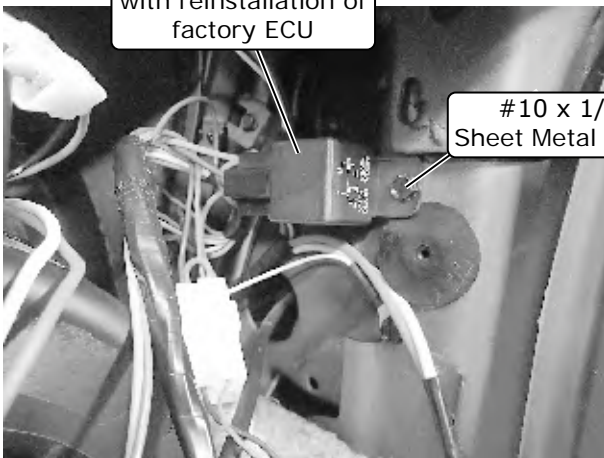


www.vintageair.com

## Wiring Installation (Cont.)

5. Select a suitable location for the main relay, then secure it using a #10 x 1/2" sheet metal screw. **NOTE: For Magnum kit, choose a location that does not interfere with the reinstallation of the factory ECU (See Photo 5, below). For Magnum Max kit, the relay may be mounted where the factory ECU was located (See Photo 6, below).**
6. Select a suitable ground location for the white ground wire eyelet from the heater control valve harness, then secure it using a #10 x 1/2" sheet metal screw (See Photo 7, below).
7. Plug the main wiring harness into the ECU (See Photo 8, below).

Choose location that does not interfere with reinstallation of factory ECU

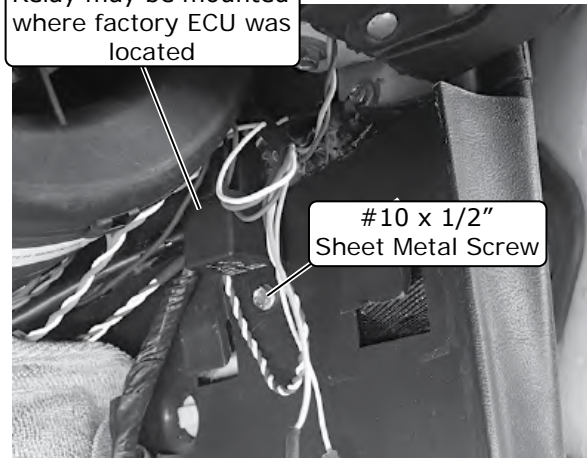


Magnum Kit Relay Mounting

Photo 5

#10 x 1/2"  
Sheet Metal Screw

Relay may be mounted where factory ECU was located

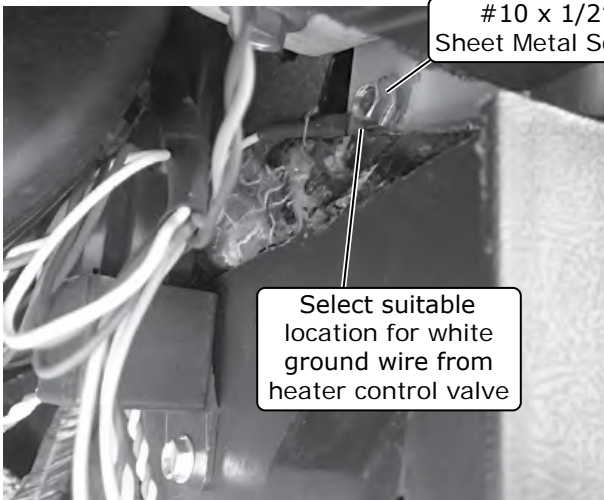


Magnum Max Kit Relay Mounting

Photo 6

#10 x 1/2"  
Sheet Metal Screw

#10 x 1/2"  
Sheet Metal Screw



Select suitable location for white ground wire from heater control valve

Photo 7

Plug main wiring harness into ECU

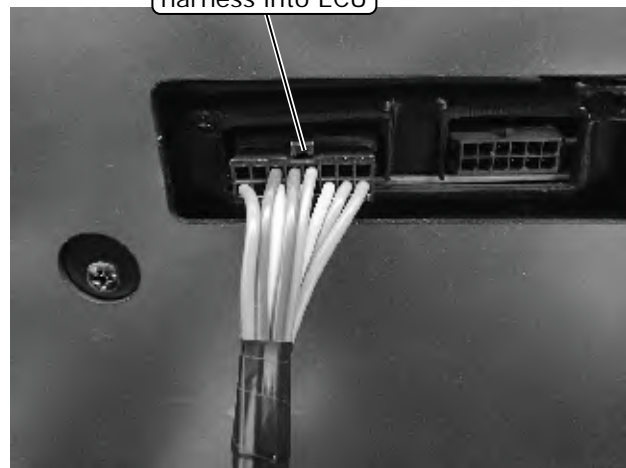


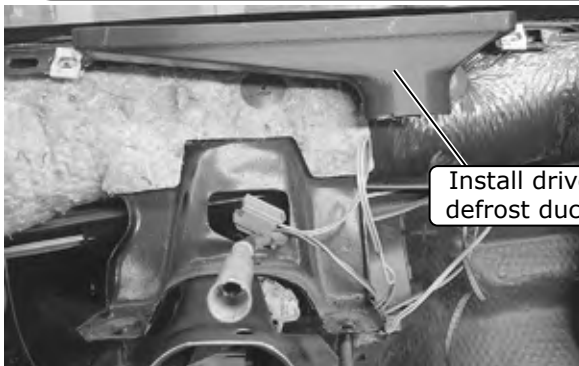
Photo 8



www.vintageair.com

## Defrost Duct and Dash Installation

1. Install the driver- and passenger-side defrost ducts using the OEM hardware (See Photos 1 and 2, below).  
**NOTE: The hose adapter openings face the center of the vehicle.**
2. Reinstall the dash at this time using the OEM hardware.
3. Secure the dash to the new support bracket using a 1/4-20 x 1/2" hex bolt and a 9/32" flat washer (See Photo 3, below).
4. Tighten the support bracket mounting bolts at this time (See Photo 4, below).
5. Secure the steering column with OEM hardware.
6. Connect all the electrical connections disconnected during the disassembly process.
7. Install the duct hoses as shown on Page 41.
8. Connect the duct hose to the driver-side louver adapter, then reinstall the gauge reinforcement housing using the OEM hardware.
9. Reinstall the gauge cluster and trim, ensuring the speedometer cable and all plugs are connected.
10. Install the 2" duct hose and splitter to the under-column louver (See Figure 1, below), then reinstall the under-column cover using the OEM hardware (See Photo 5, below).

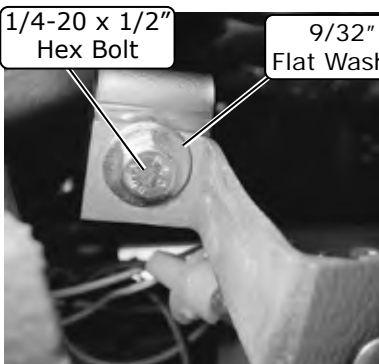


Install driver- and passenger-side defrost ducts using OEM hardware



Photo 2

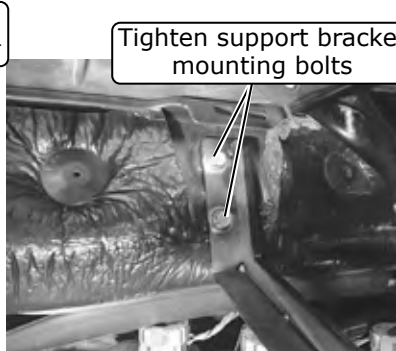
Photo 1



1/4-20 x 1/2" Hex Bolt

9/32" Flat Washer

Photo 3



Tighten support bracket mounting bolts

Photo 4

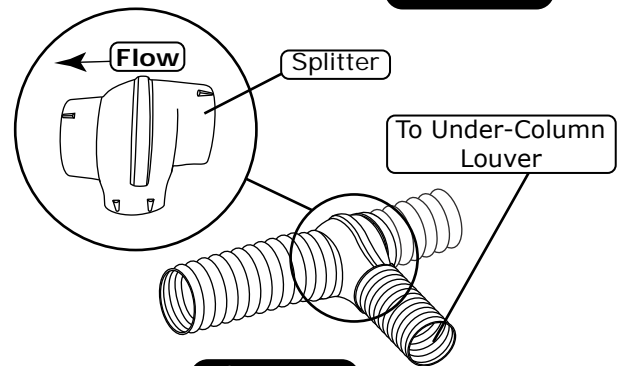
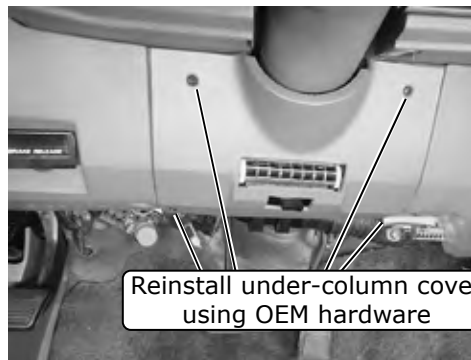


Figure 1



Reinstall under-column cover using OEM hardware

Photo 5



www.vintageair.com

## Passenger Compartment Wiring

**NOTE:** If using the factory wiring for power, the OEM A/C fuse must be changed to a 5 AMP on the fuse panel.

1. Route the violet power wire to a switched 12v power source on the fuse panel.
2. Connect the tan wire to the factory dash lights to enable control panel backlighting.

## Control Panel Installation

1. Route the new control panel wiring towards the ECU.
2. Install the control panel into the OEM location using the OEM hardware (See Photo 1, below).
3. Connect the control panel harness plug to the ECU (See Photo 2, below).
4. Reinstall the dash trim (See Photo 3, below).

Install control panel into OEM location using OEM hardware



Photo 1

Connect control panel harness plug to ECU



Photo 2

Reinstall dash trim



Photo 3

## Inner Fender Reinstallation

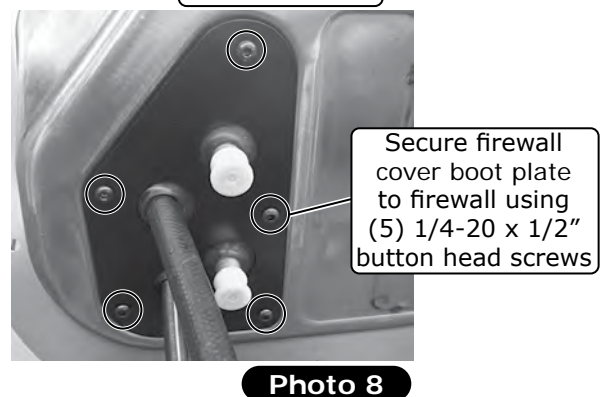
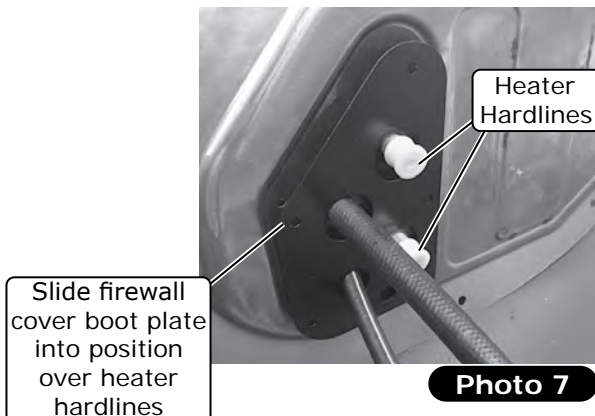
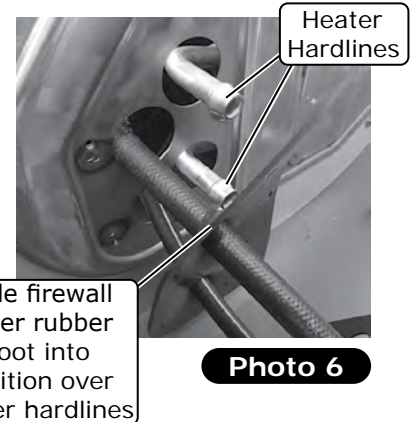
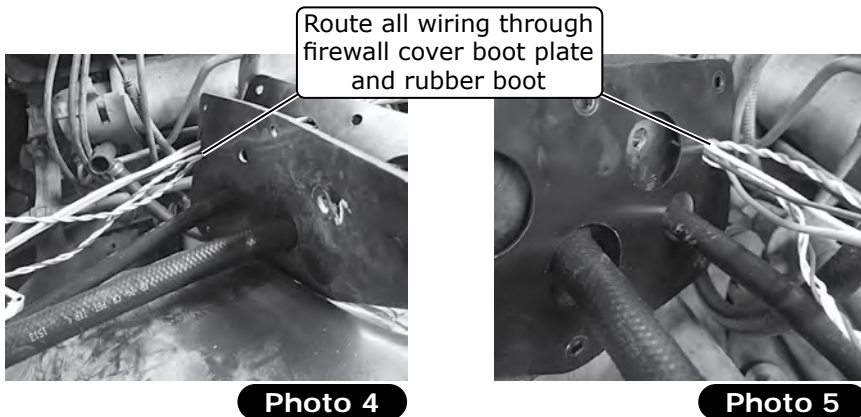
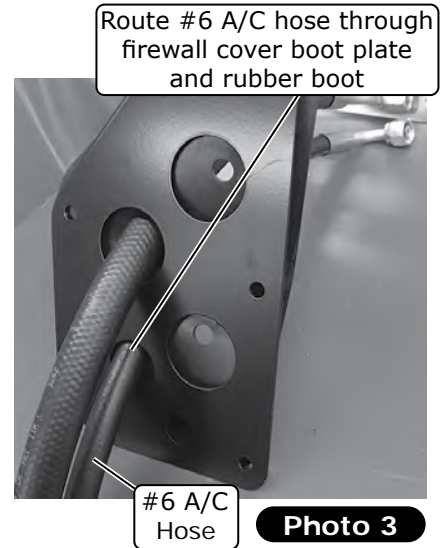
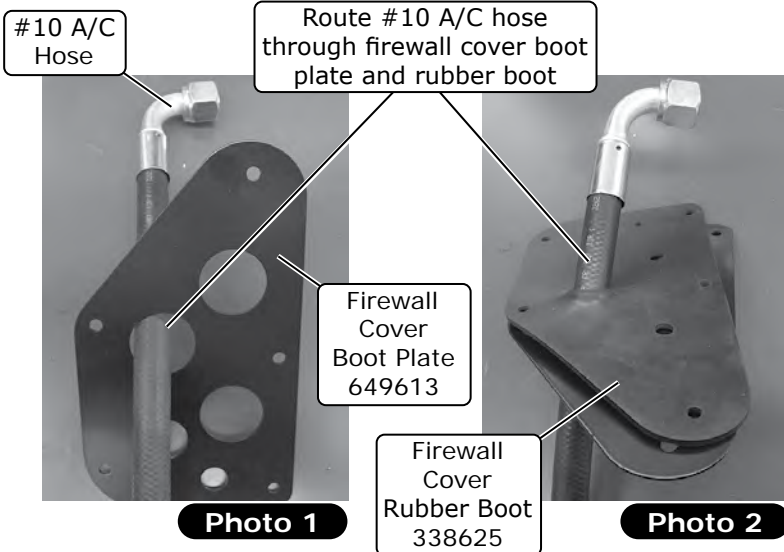
1. Reinstall the passenger inner fender at this time using OEM hardware.



www.vintageair.com

# Firewall Cover Boot Plate Installation

1. Route the #10 A/C hose through the firewall cover boot plate and rubber boot (See Photos 1 and 2, below).
2. Route the #6 A/C hose through the firewall cover boot plate and rubber boot (See Photo 3, below).
3. Route all the wiring through the firewall cover boot plate and rubber boot (See Photos 4 and 5, below).
4. Slide the firewall cover boot plate and rubber boot into position over the heater hardlines (See Photos 6 and 7, below).
5. Secure the firewall cover boot plate to the firewall cover using (5) 1/4-20 x 1/2" button head screws (See Photo 8, below).





www.vintageair.com

## A/C Hose Installation

**NOTE: Be sure to use a backup wrench when connecting A/C hoses and hardlines to avoid damaging hose fittings (See Lubricating O-rings, Page 17).**

1. With a properly lubricated #10 O-ring (See Lubricating O-rings, Page 17), install the 90° fitting of the #10 A/C hose onto the #10 fitting on the evaporator module expansion valve (See Photo 1, below).
2. With a properly lubricated #6 O-ring (See Lubricating O-rings, Page 17), install the 90° fitting of the #6 A/C hose onto the #6 fitting on the evaporator module expansion valve (See Photo 2, below).
3. Using the supplied press tape, wrap all exposed metal from the A/C hoses to the evaporator module expansion valve as shown in Photo 3, below.
4. Route the #6 A/C hose along the inner fender. With a properly lubricated #6 O-ring (See Lubricating O-rings, Page 17), connect the #6 straight fitting to the #6 drier hardline (See Photo 4, below).
5. Install a #6 Adel clamp onto the #6 A/C hose, and secure it to the inner fender using a 10-32 x 1/2" screw and a 10-32 nut with star washer (See Photo 5, below).

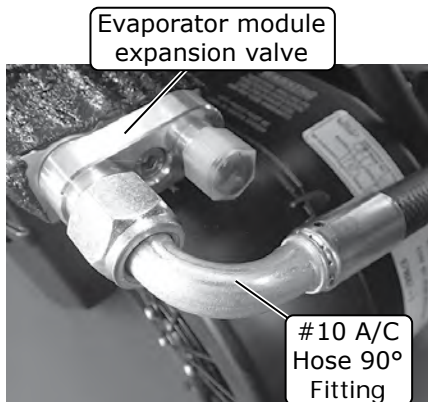


Photo 1

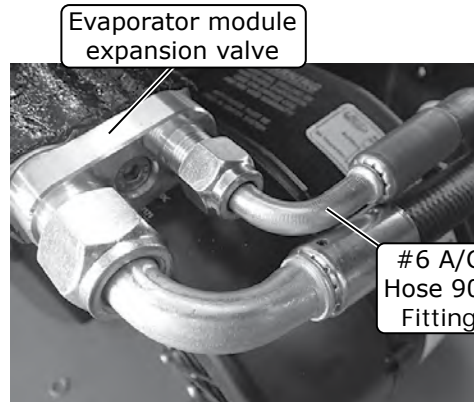


Photo 2

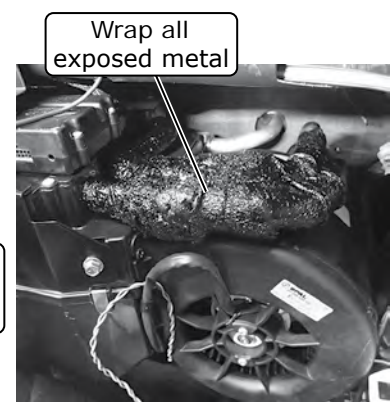


Photo 3

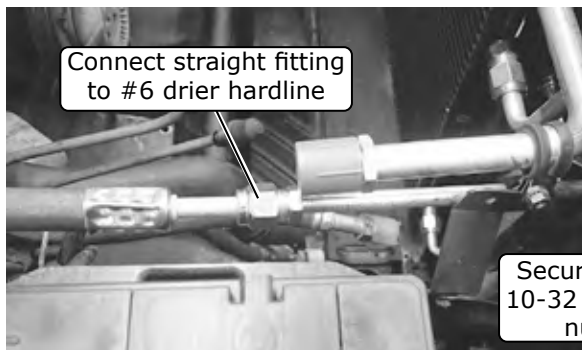


Photo 4

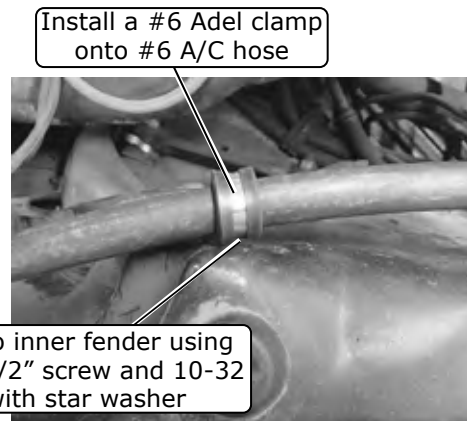


Photo 5



www.vintageair.com

## A/C Hose Installation (Cont.)

6. With a properly lubricated #10 O-ring (See Lubricating O-rings, Page 17), connect the #10 straight fitting of the #10 A/C hose to the evaporator hardline (See Photo 6, below).
7. Route the #10 A/C hose along the inner fender. With a properly lubricated #10 O-ring (See Lubricating O-rings, Page 17), connect the #10 straight fitting to the #10 hardline fitting at the condenser (See Photo 7, below).
8. With a properly lubricated #10 O-ring (See Lubricating O-rings, Page 17), connect the #10 straight fitting with the service port on the #10 compressor A/C hose to the #10 fitting at the condenser (See Photo 8, below).
9. With a properly lubricated #10 O-ring (See Lubricating O-rings, Page 17), connect the #10 45° fitting to the suction port on the compressor (See Photo 9, below).
10. With a properly lubricated #8 O-ring (See Lubricating O-rings, Page 17), connect the straight fitting with the service port on the #8 A/C hose to the #8 hardline fitting at the condenser (See Photo 10, below).

Connect straight fitting of #10 A/C hose to evaporator hardline



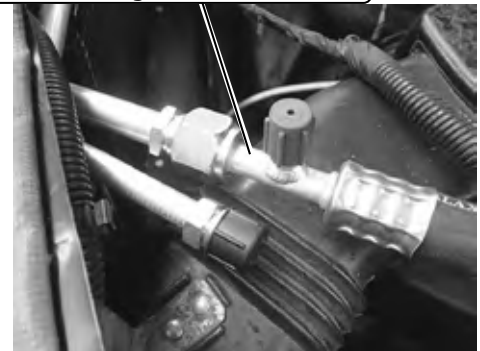
**Photo 6**

Connect straight fitting to #10 hardline fitting at condenser



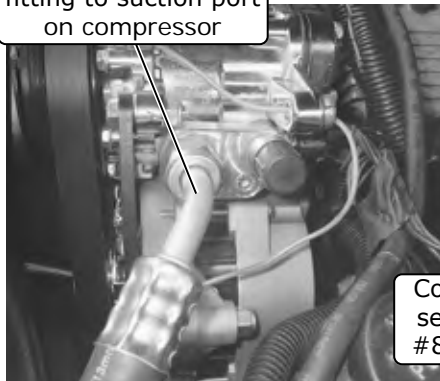
**Photo 7**

Connect straight fitting with service port of #10 compressor A/C hose to #10 fitting at condenser



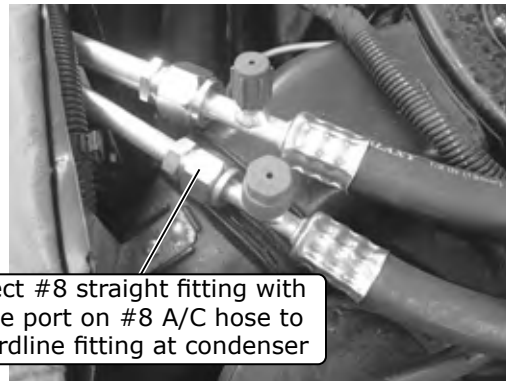
**Photo 8**

Connect #10 45° fitting to suction port on compressor



**Photo 9**

Connect #8 straight fitting with service port on #8 A/C hose to #8 hardline fitting at condenser



**Photo 10**

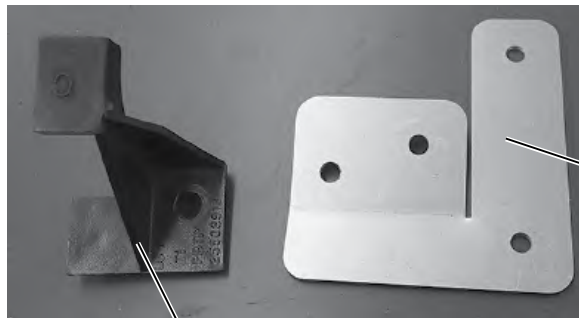


www.vintageair.com

## Water Deflector Installation

**NOTE: The hood weather stripping may have to be trimmed to fit correctly.**

1. Remove the windshield washer nozzle from the OEM bracket.
2. Secure the windshield washer nozzle onto the new washer nozzle bracket using a 10-32 x 1/2" screw and a 10-32 nut with star washer (See Photos 1 and 2, below).
3. Install the windshield washer nozzle assembly onto the water deflector using (2) 10-32 x 1/2" screws and (2) 10-32 nuts with star washers (See Photos 3 and 4, below).
4. Install the water deflector using OEM trim brackets and hardware.
5. Route the windshield water nozzle hose as shown in Photo 5, below, and reconnect it onto the washer nozzle.
6. Reinstall the hood weather stripping (use silicone if needed) (See Photo 6, below).
7. Reinstall the lower windshield trim using the OEM hardware.
8. Reinstall the windshield wiper arms.



Windshield Washer Nozzle

Photo 1

Windshield Washer Nozzle Bracket 649631

Secure washer nozzle to bracket using a 10-32 x 1/2" screw and a 10-32 nut with star washer

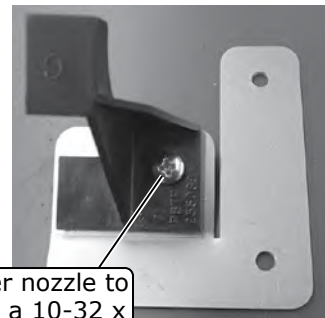
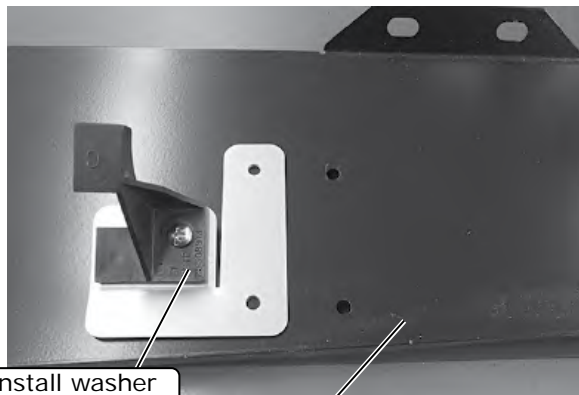


Photo 2



Install washer nozzle assembly onto water deflector

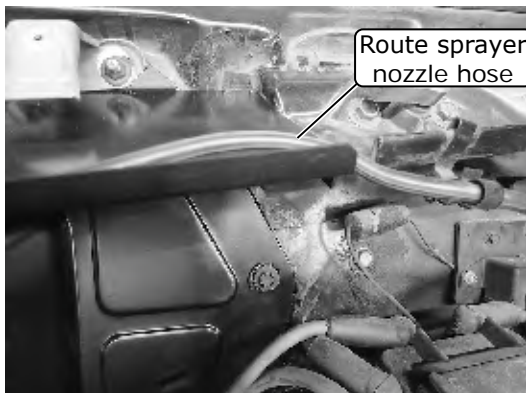
Water Deflector 649606

Photo 3



Secure using (2) 10-32 x 1/2" screws and (2) 10-32 nuts with star washers

Photo 4



Route sprayer nozzle hose

Photo 5



Reinstall hood weather stripping

Photo 6



www.vintageair.com

# Heater Hose & Heater Control Valve Installation

**NOTE:** Vintage Air systems use 5/8" heater connections. On engines equipped with 3/4" hose nipples, these will need to be removed and replaced with 5/8" nipples (not supplied). For water pumps with a cast-in 3/4" heater outlet, a 3/4" x 5/8" reducer fitting (not supplied) or molded hose will need to be installed in the heater hose.

1. Route a length of heater hose from the lower heater hardline to the OEM heater hardline connected to the water pump, and secure it using (2) hose clamps (See Photo 1, below). **NOTE: A molded 90° heater hose was used in this installation and is not included in the kit.**
2. Cut the upper heater hose approximately 13" and attach it to the heater control valve. Secure it using a hose clamp as shown in Photo 2, below. **NOTE: Ensure proper flow direction through the heater control valve. The flow direction follows the molded arrow on the valve (See Figure 1, below).**
3. Attach a length of heater hose approximately 14" to the heater control valve (See Photo 3, below), then attach the heater hose to the OEM heater hardline connected to the intake manifold. Secure using (2) hose clamps (See Photo 4, below).

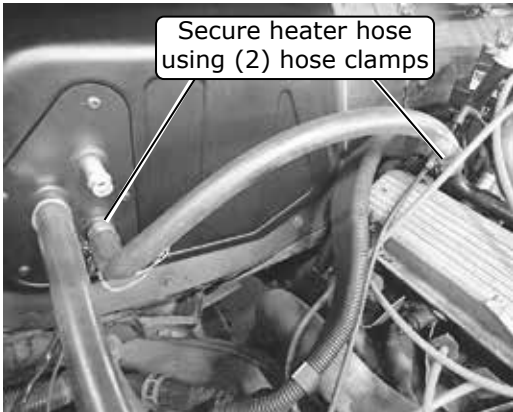


Photo 1

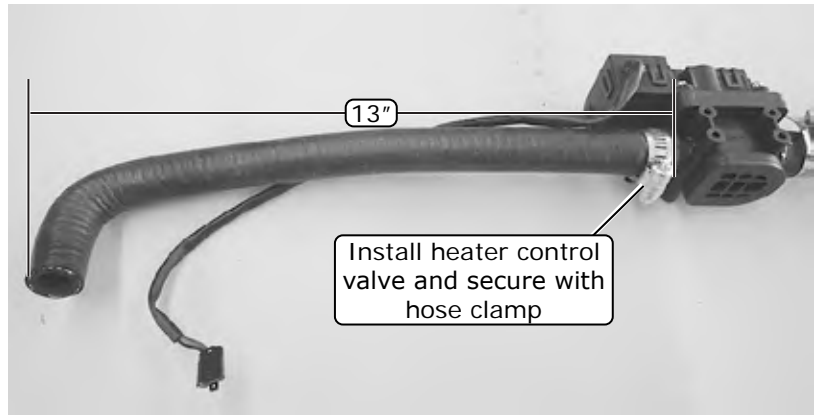


Photo 2

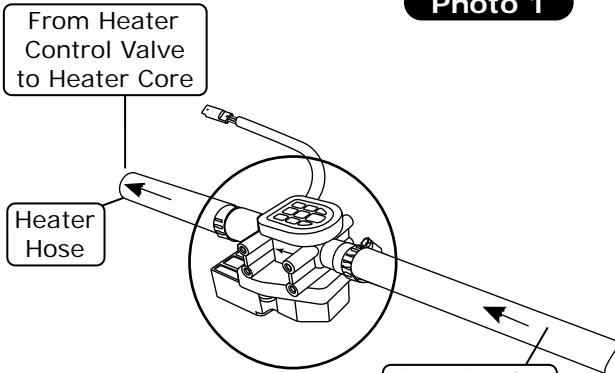


Figure 1

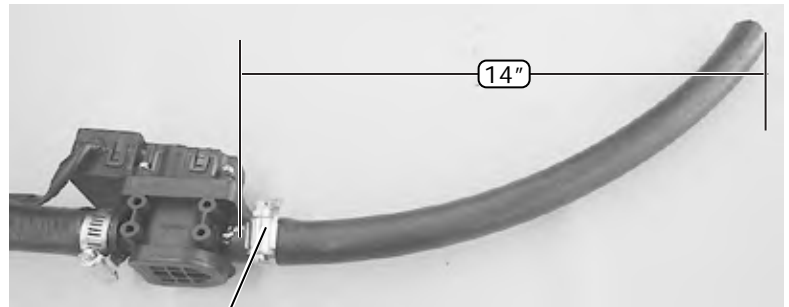


Photo 3

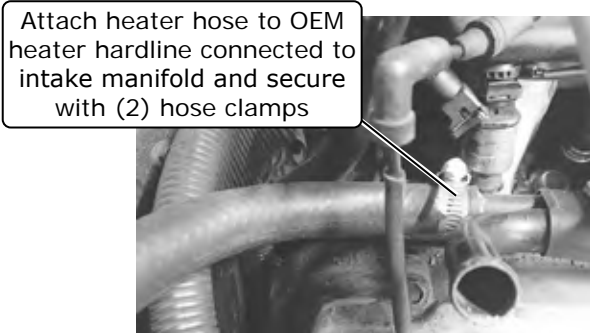


Photo 4



www.vintageair.com

## Heater Hose & Heater Control Valve Installation (Cont.)

4. Route the heater control valve wiring along the heater hose, and secure it with the supplied tie wraps (See Photo 5, below).
5. Plug the heater control valve connector into the heater control valve connector wiring harness (See Photo 6, below).

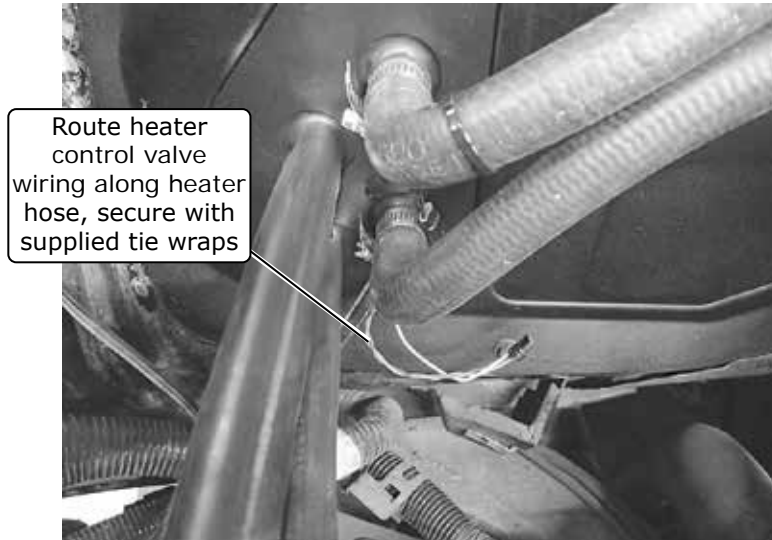


Photo 5



Photo 6

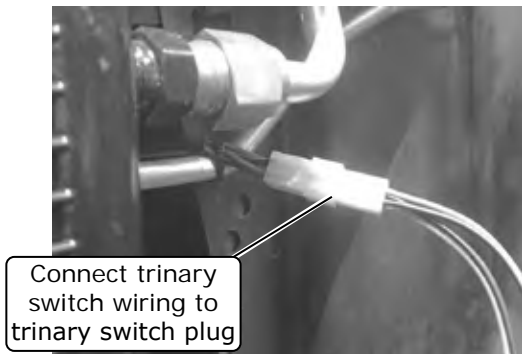


www.vintageair.com

## Engine Compartment Wiring

**NOTE:** This kit is designed for the factory electric fan and will have to be integrated into the vehicles wiring harness. Side post battery terminal extensions (not included) may be needed to connect the power and ground connections to the battery.

1. Connect the trinary switch wiring to the trinary switch plug (See Photo 1, below).
2. Route the blue wire from the main wiring harness along the #6 A/C hose. Using the supplied butt connector and heat shrink, connect the short blue wire from the trinary switch to the blue wire from the main wiring harness (See Photos 2 and 3, below). Secure the wiring to the #6 A/C hose using tie wraps.
3. Route the blue and (2) black wires along the #10 condenser hardline and the #10 A/C hose toward the compressor. **NOTE: Cover the wires with the supplied flexo sleeve. Secure wiring to the hardline and hose using tie wraps (See Photo 4, below).**
4. Connect the blue bullet connector to the compressor lead (See Photo 5, below).



Connect trinary switch wiring to trinary switch plug

Photo 1

Using supplied butt connector, connect short blue wire from trinary switch to blue wire from main wiring harness

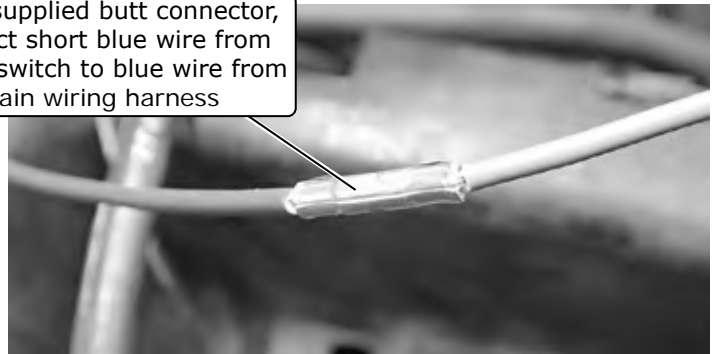


Photo 2

Using supplied heat shrink, connect short blue wire from trinary switch to blue wire from main wiring harness

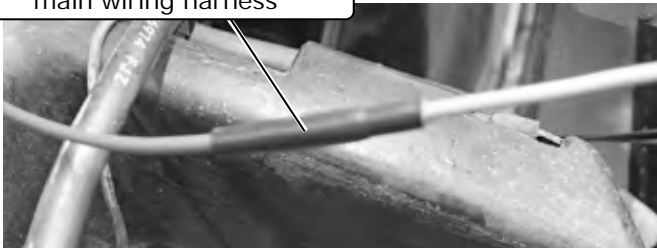
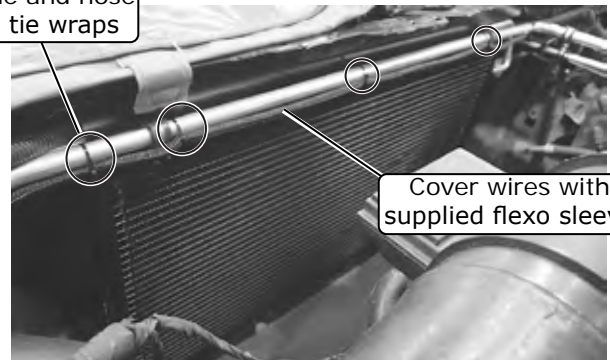


Photo 3

Secure wiring to hardline and hose using tie wraps



Cover wires with supplied flexo sleeve

Photo 4

Connect blue bullet connector to compressor lead



Photo 5



www.vintageair.com

## Engine Compartment Wiring (Cont.)

5. Locate the OEM A/C high-pressure fan switch connector (See Photo 6, below), and cut the black with white stripe wire (See Photo 7, below). Using the supplied butt connector and heat shrink, connect one of the trinary switch harness black wires to the black with white stripe wire of the OEM A/C high-pressure fan switch wiring.
6. Cut the remaining (2) wires from the OEM A/C high-pressure fan switch connector (green and green with yellow) (See Photo 8, below). Using the butt connector and heat shrink provided in the evaporator installation kit, connect the (2) wires from the OEM A/C high-pressure fan switch to the remaining black wire (See Photo 9, below). **NOTE: Vintage air recommends that the trinary switch wire be folded to make a secure crimp connection.**
7. Route the power and ground wires toward the battery.
8. Install the supplied heat shrink over the 12 AWG orange fuse holder assembly wire and crimp it to the 12 AWG orange wire from the main wiring harness (See Photo 10, below).
9. Install the supplied heat shrink over the 16 AWG black fuse holder assembly wire and crimp it to the 16 AWG red wire from the main wiring harness (See Photo 11, below).

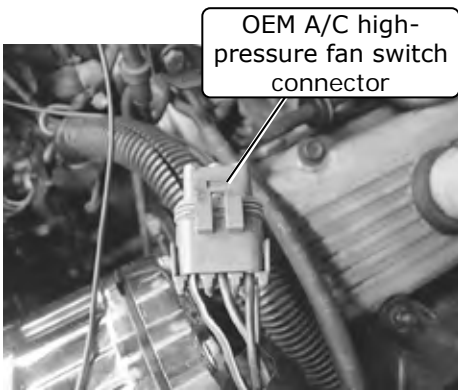


Photo 6

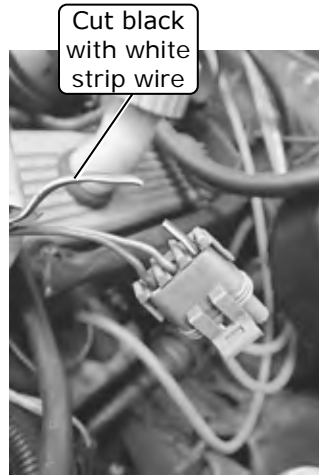


Photo 7

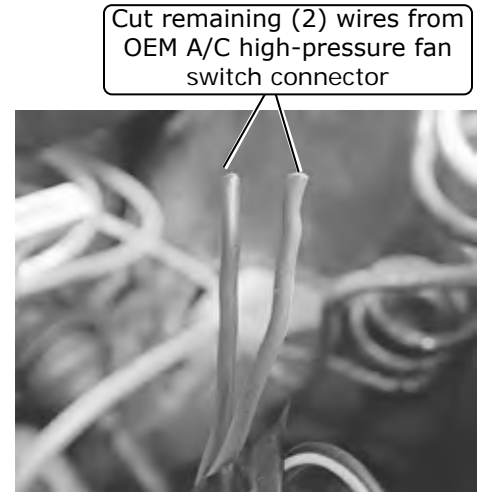


Photo 8

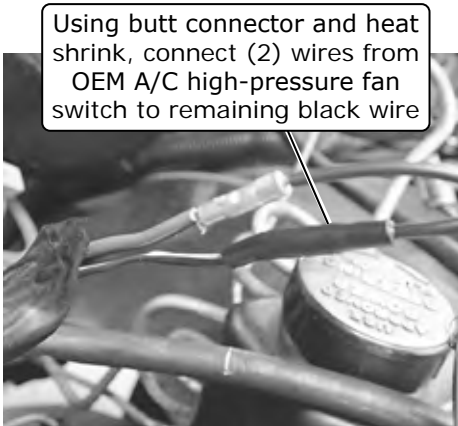


Photo 9

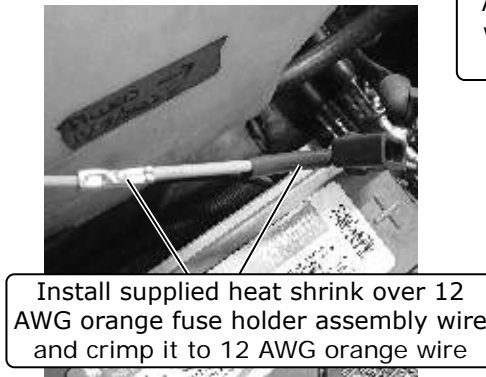


Photo 10

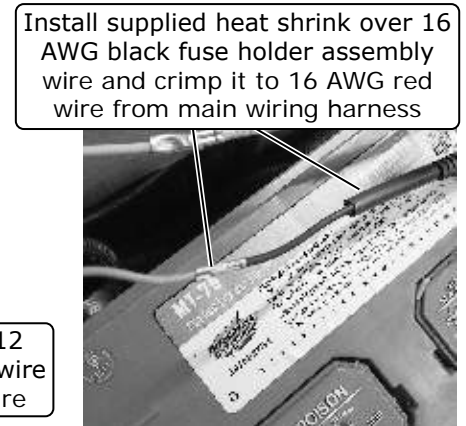


Photo 11



www.vintageair.com

## Engine Compartment Wiring (Cont.)

10. Install the fuses into the holders (See Photos 12 and 13, below).
11. Install the supplied heat shrink over the white ground wires, then crimp on the supplied eyelets (See Photos 14 and 15, below).
12. Connect the ground wiring eyelets to the negative battery terminal connector.
13. Connect the positive wiring eyelet to the positive battery terminal connector. **NOTE: Do not connect power until the installation is completed.**
14. Wrap exposed wiring using the supplied split sleeve.



Photo 12

Install fuses into holders

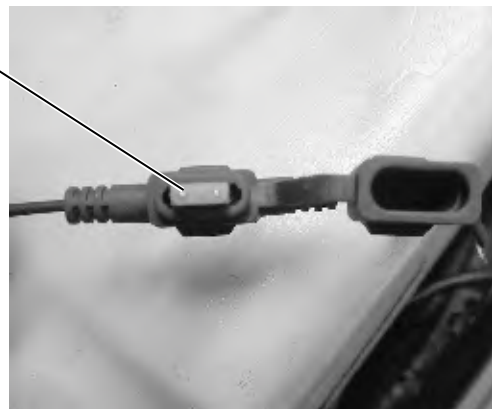


Photo 13

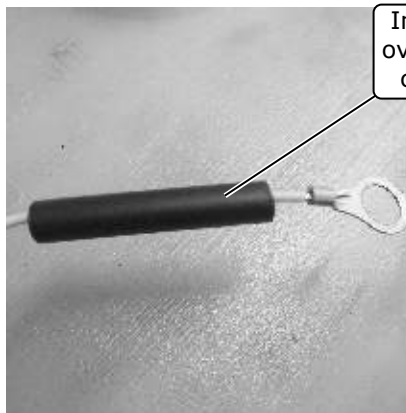


Photo 14

Install supplied heat shrink over white ground wires and crimp on supplied eyelets

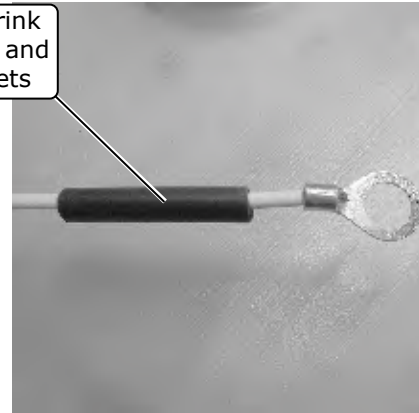


Photo 15



www.vintageair.com

## Drain Hose Installation

1. Cut the drain hose at 9" (See Photo 1, below). Install the drain tube elbow and the remainder of the hose. Install the 9" piece of drain hose through the pre-drilled hole in the firewall from the engine compartment (See Photo 2, below), and connect the drain hose to the drain outlet on the evaporator module (See Photo 3, below). In the engine compartment, route the drain hose away from the exhaust. **NOTE: Carpet may need to be trimmed.**

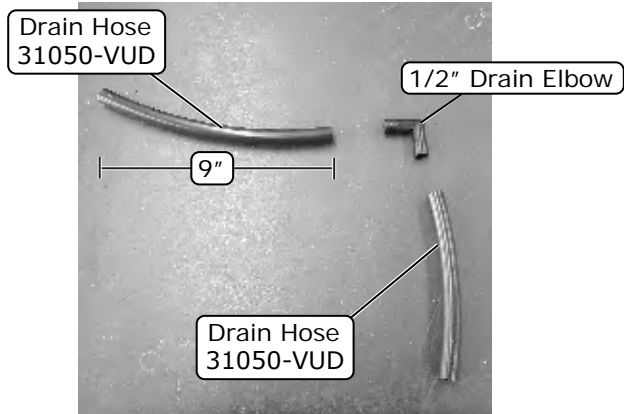


Photo 1

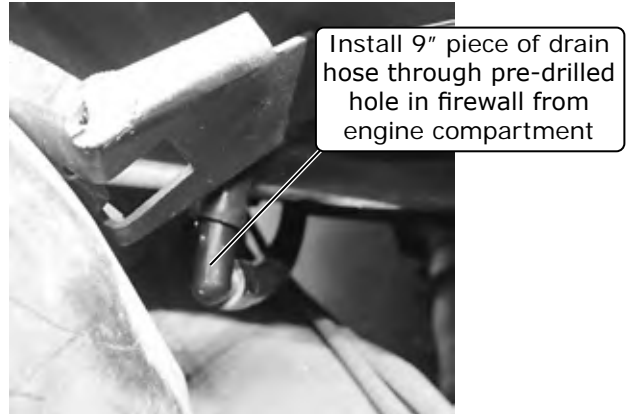


Photo 2



Photo 3

## Courtesy Lamp Relocation (If Equipped)

1. Install the courtesy lamp bracket onto the lamp using the OEM hardware (See Photo 1, below).
2. Using a #8 x 1/2" pan head screw, install the lamp using the mounting hole on the bottom of the evaporator module (See Photos 2 and 3, below).

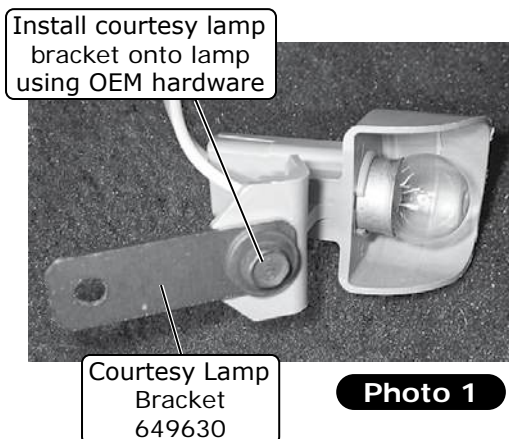


Photo 1



Photo 2



Photo 3



www.vintageair.com

## OEM ECU Relocation (Magnum Max Only)

1. When installing the Gen 5 Magnum Max kit, the OEM ECU will have to be relocated from its factory location. When designing this kit, the OEM ECU was relocated under the evaporator module on the passenger side, under the carpet (See Photo 1, below).

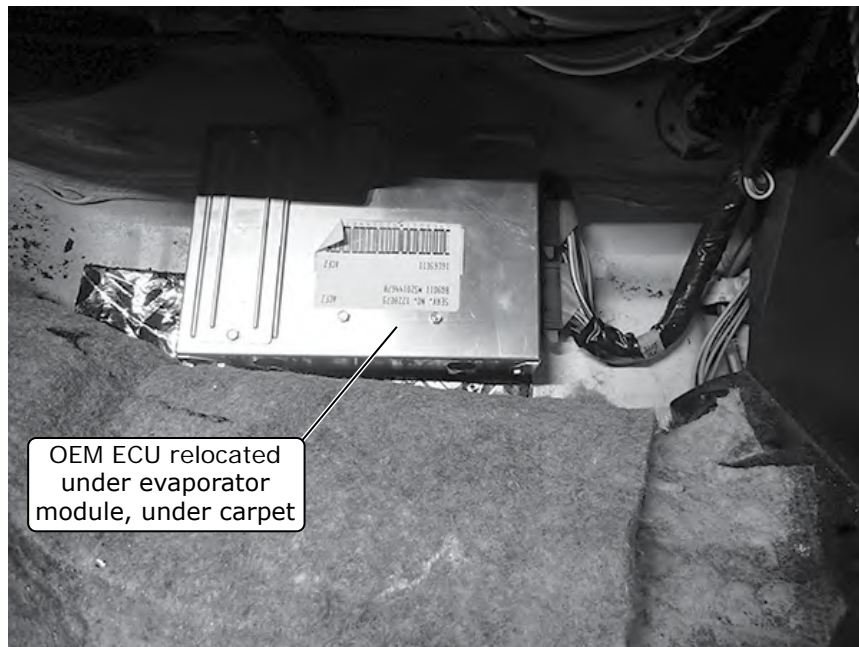


Photo 1



www.vintageair.com

## Glove Box Modification and Installation (Style 1)

1. Using the template, mark and cut the glove box (See Photos 1, and 2, below).
2. Install the glove box cap over the trimmed area. Using the (2) bottom holes, drill (2) small pilot holes onto the glove box, then secure the cap using (4) 6 x 3/8" pan head screws (See Photo 3, below).
3. Reinstall the glove box/door using the OEM hardware.



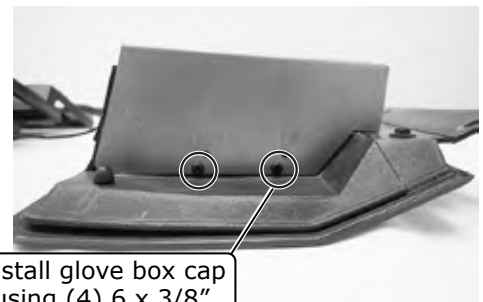
Glove Box Template 649626

Photo 1



Cut Glove Box

Photo 2

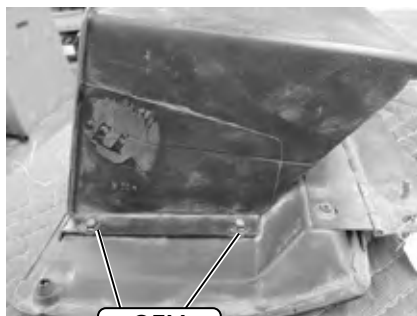


Install glove box cap using (4) 6 x 3/8" pan head screws

Photo 3

## Glove Box Modification and Installation (Style 2)

1. For glove boxes that mount to the door with OEM screws (See Photo 1, below), use the template to mark and cut the glove box (See Photos 2 and 3, below).



OEM Screws

Photo 1



Glove Box Template 649626

Photo 2



Cut Glove Box

Photo 3



www.vintageair.com

## Glove Box Modification and Installation (Style 2) (Cont.)

2. Install the glove box cap over the trimmed area. Using the (2) upper holes (See Photo 4, below), drill (2) small pilot holes onto the glove box, then secure the cap using (4) pop rivets, ((2) per side) (See Photos 5 and 6, below).
3. Reinstall the glove box/door using the OEM hardware.

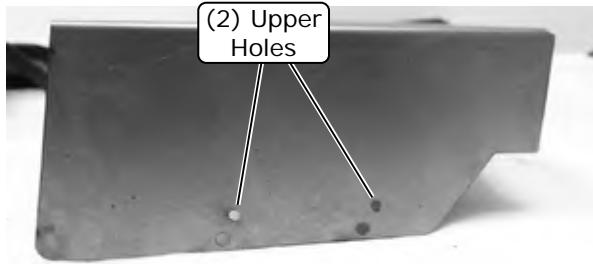


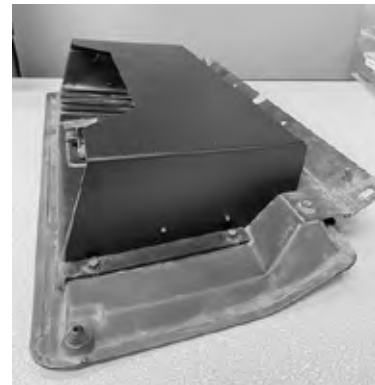
Photo 4



Photo 5



Photo 6



Final Install



www.vintageair.com

# Final Steps: Installation Check

Installation Check	
ITEM TO CHECK	Procedure
<input type="checkbox"/>	<p>ECU</p> <p>If no blinking is observed after 1 minute of turning the ignition on, go to the next check.</p> <p>If repetitive blinking is observed, go to the <b>Advanced Diagnostics</b> Section to diagnose.</p>
<input type="checkbox"/>	<p>Blower speed control</p> <p>Set the blower speed control to <b>OFF</b>, <u>confirm that the blower is off</u>.</p> <p>Position the blower speed control to <b>LOW</b> then <b>MEDIUM</b> and then <b>HIGH</b>. <u>At each setting confirm that the blower speed increases</u>, do this by feeling for the amount of air coming from the unit and hearing the blower speed increase.</p>
<input type="checkbox"/>	<p>Mode control</p> <p>Set the <b>MODE</b> control to the <b>DASH</b> position. <u>Confirm that air is being blown at the dash vents</u>.</p> <p>Set the <b>MODE</b> control to the <b>FLOOR</b> position. <u>Confirm that air is being blown at the floor vents</u>.</p> <p>Set the <b>MODE</b> control to the <b>DEFROST</b> position. <u>Confirm that all air is being blown from the defrost vents</u></p> <p><b>If heater lines are installed:</b></p> <p>Set the <b>MODE</b> control to the <b>DASH</b> position. Set the <b>TEMP</b> control to the <b>MAX HEAT</b> position. <u>Confirm that HOT air is coming from the dash vents</u>.</p>
<input type="checkbox"/>	<p>Temperature control</p> <p><b>If system is charged:</b></p> <p>Set the <b>TEMP</b> control to the <b>MAX COOL</b> position. <u>Confirm that COLD air is coming from the dash vents</u>.</p> <p>Also <u>confirm that the compressor "clicks" on</u> when adjusting the <b>TEMP</b> control from the <b>MAX HEAT</b> position to the <b>MAX COOL</b> position.</p>
<input type="checkbox"/>	<p>AC Indicator (If applicable)</p> <p>While the <b>MODE</b> control is set to the <b>DASH</b> position, and the <b>TEMP</b> control is set to the <b>MAX COOL/MIN HEAT</b> position, <u>confirm that the blue AC Indicator light is on</u>.</p>
<input type="checkbox"/>	<p>Backlight (If applicable)</p> <p>If your control panel has backlight capabilities and has been wired, turn the dash lamp on and <u>confirm that the AC panel's legend is lit</u>.</p>
<input type="checkbox"/>	<p>Fittings</p> <p>Verify AC and Heater fittings are all tight.</p>



www.vintageair.com

## ***Final Steps: Completing the Install***

1. If using the OEM A/C power wire to connect to the violet power wire from the main harness, remove the fuse for the factory A/C from the fuse panel and replace it with the supplied 5 amp fuse.
2. Reinstall all previously removed items.
3. Fill radiator with at least a 50/50 mixture of approved antifreeze and distilled water. It is the owner's responsibility to keep the freeze protection at the proper level for the climate in which the vehicle is operated. Failure to follow antifreeze recommendations will cause heater core to corrode prematurely and possibly burst in A/C mode and/or freezing weather, voiding your warranty.
4. Double-check all fittings, brackets and belts for tightness.
5. Vintage Air recommends that all A/C systems be serviced by a licensed automotive A/C technician.
6. Evacuate the system for a minimum of 45 minutes prior to charging, and perform a leak check prior to servicing.
7. Charge the system to the capacities stated on Page 4 of this instruction manual.
8. See Operation of Controls procedures on Page 45.



www.vintageair.com

## Duct Hose Routing

**NOTE:** For the system to function optimally, the duct hoses must be routed as directly as possible, taking care to avoid kinks, sharp bends and unnecessary length. Vintage Air supplies duct hoses in continuous lengths that will need to be cut to size depending on application. Before cutting, familiarize yourself with the installation instructions and verify the routing will work with your application. For custom hose routing, additional hose may be needed and can be purchased from Vintage Air.

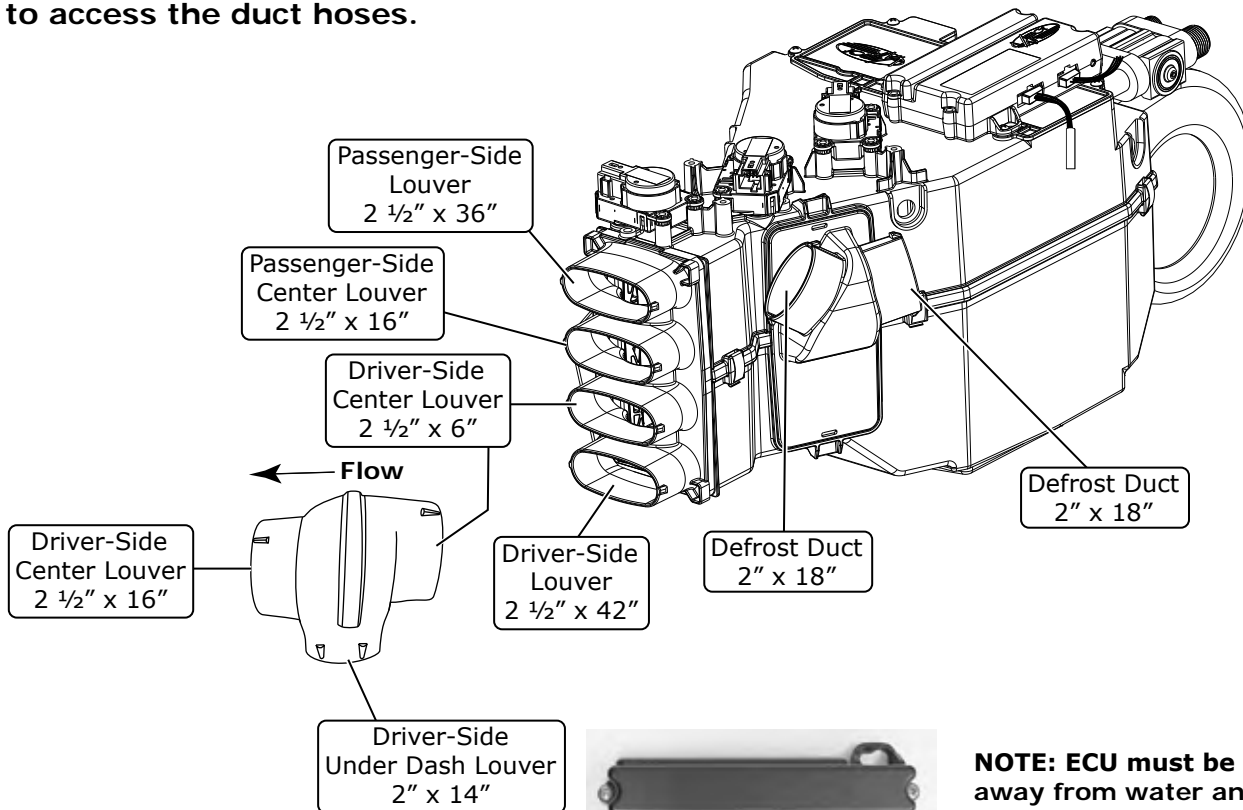
1. Stretch the duct hose until there is no slack, measure, mark and cut hose to size (See Photo 1, below).

Stretch, measure, mark and cut hose to size



Photo 1

**NOTE:** To ensure the duct hose will not disconnect from the plenums, use tie wraps or screws to secure them if loose. Once the dash is installed, it will be very difficult to access the duct hoses.



**TECH TIP:** Attach the duct hose to the center louver hose adapter before the reinstallation of the dash.



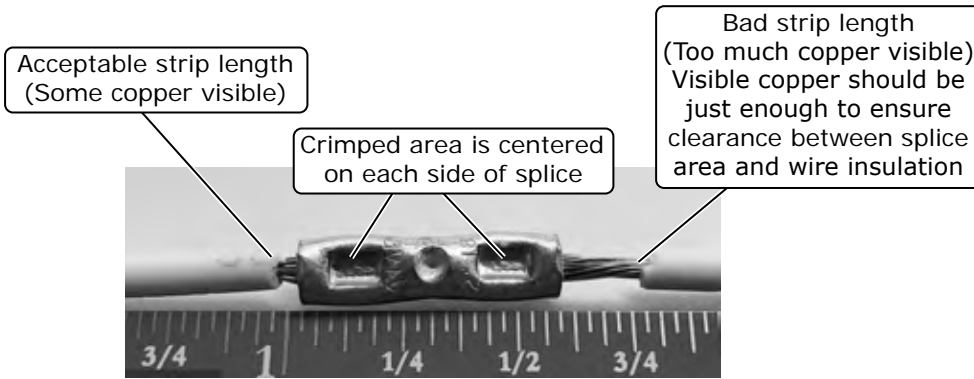
**NOTE:** ECU must be placed away from water and humidity, and also be accessible for servicing. If relocating, connectors must be positioned towards the bottom.

Position connectors towards bottom

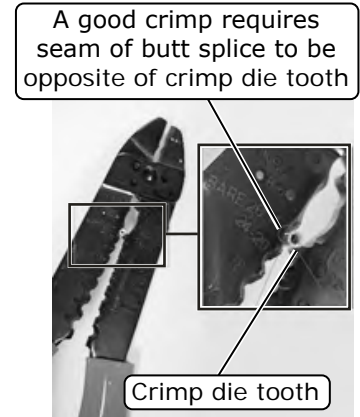


www.vintageair.com

# Quality Crimp Guideline

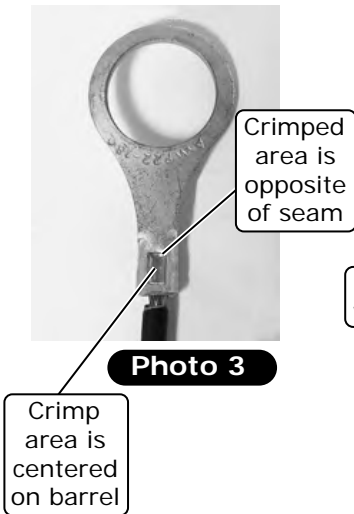


**Photo 1**

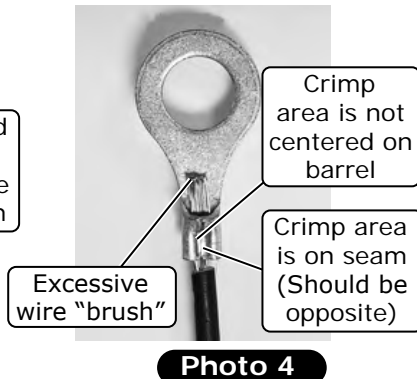


**Photo 2**

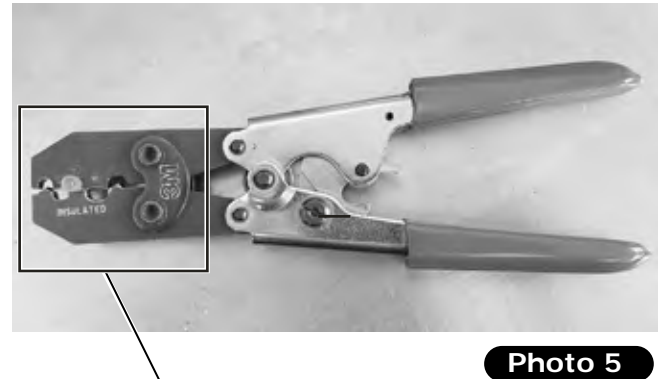
## Good Ring Terminal Crimp    Bad Ring Terminal Crimp



**Photo 3**



**Photo 4**



**Photo 5**

Use a ratcheting crimp tool for insulated barrel terminals when crimping the provided female insulated terminal. Ensure terminal is inserted in appropriate position before crimping.

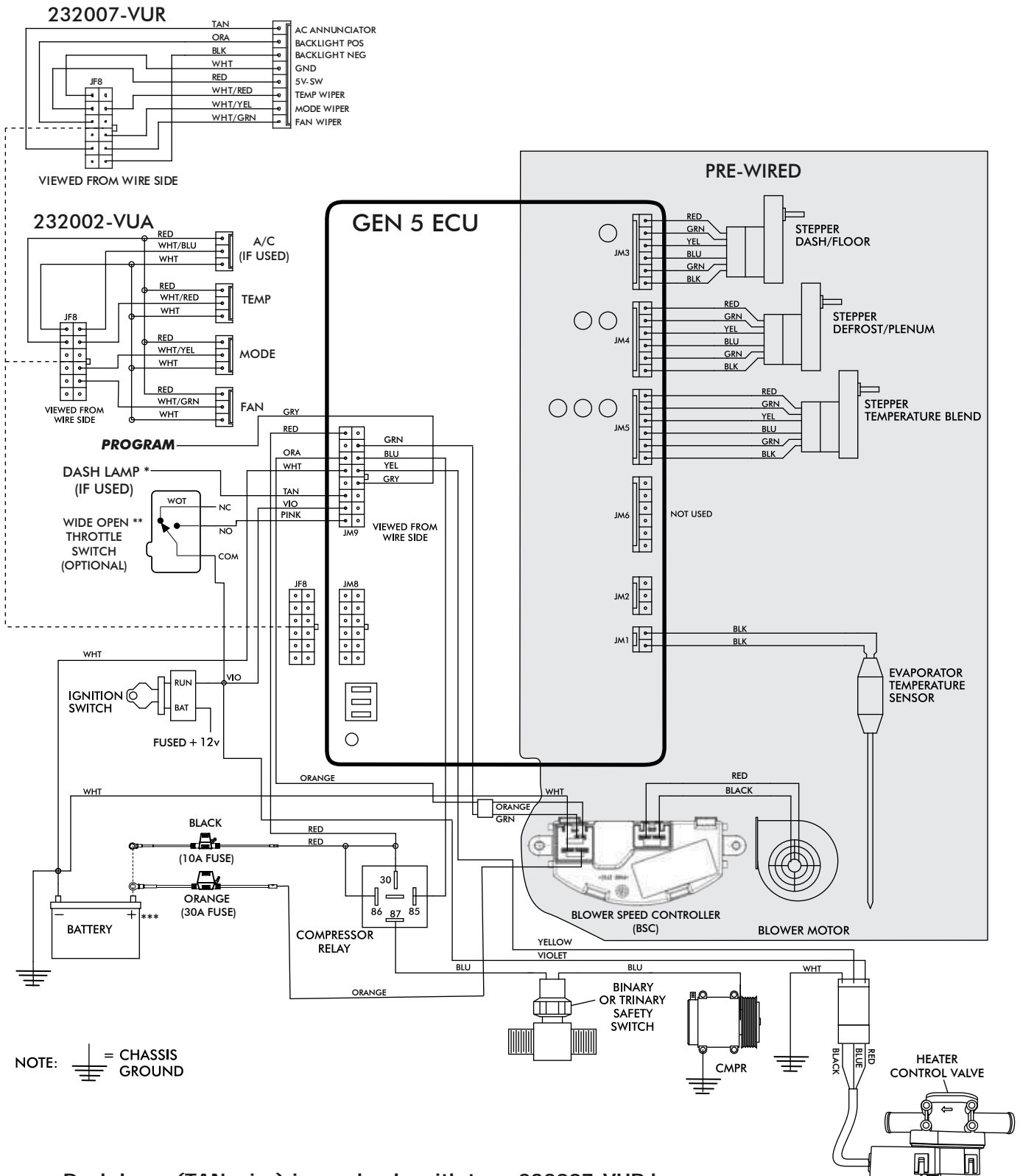


**Photo 5a**



www.vintageair.com

# Gen 5 Wiring Diagram



NOTE: = CHASSIS GROUND

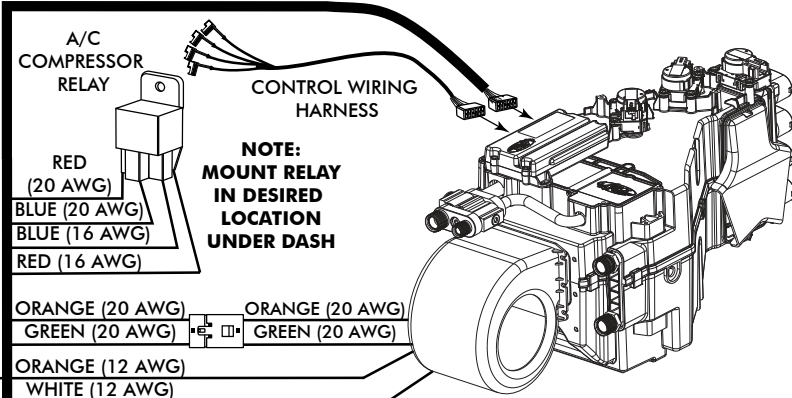
- \* Dash lamp (TAN wire) is used only with type 232007-VUR harness.
- \*\* Wide open throttle switch contacts close only at full throttle, which disables A/C compressor.
- \*\*\* Install fuse assemblies at or as near to the battery as possible.



www.vintageair.com

# Gen 5 Wiring Instructions

WIRING HARNESS (231505) ↓

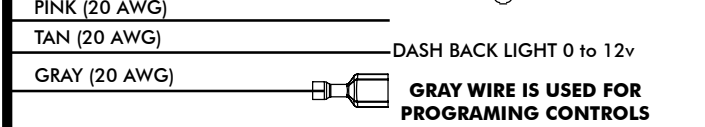
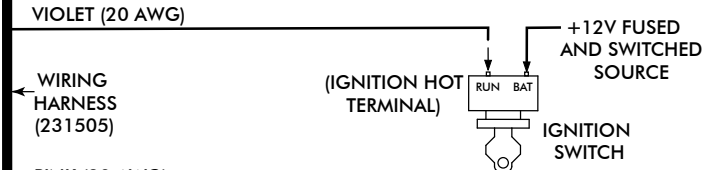


**NOTE:**  
MOUNT RELAY  
IN DESIRED  
LOCATION  
UNDER DASH

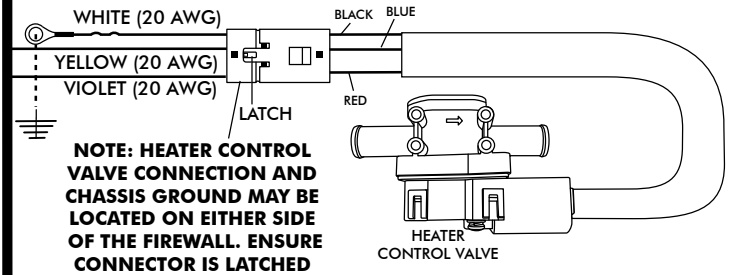
**Ignition Switch:**  
Using provided butt splice (PN 226004), connect the 20 AWG violet wire to a 5A fused and switched 12V source such as Key On.

**Wide Open Throttle Switch (Optional):**  
If a wide open throttle switch is required, connect the 20 AWG pink wire to a normally open switch that, when closed, connects a fused and switched 12V source to the pink wire. See Gen 5 wiring diagram for an example.

**Dash Light (Optional):**  
If using a Vintage Air control panel with back light, connect the 20 AWG tan wire to the vehicle's dash back light 0-12V using provided butt splice (PN 226004).

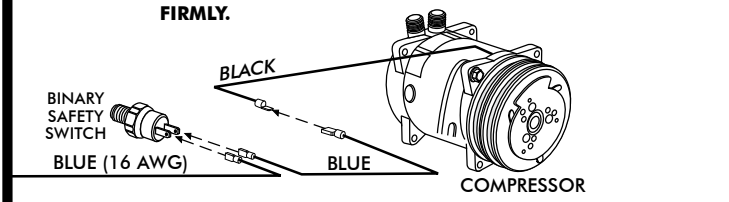


FIREWALL

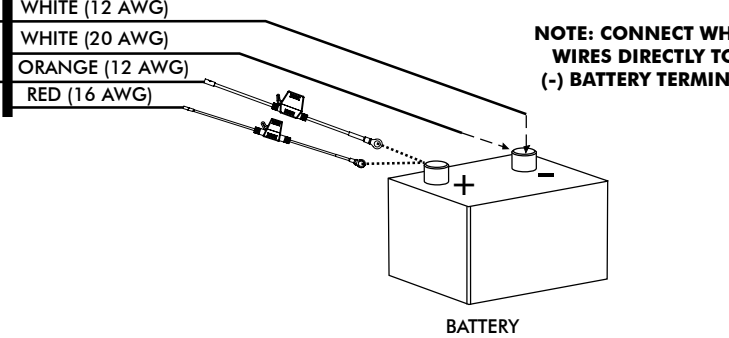


**Heater Control Valve:**  
Connect the Violet/Yellow/White twisted branch with 3 position connector into the heater control valve connector. Ensure that the mating latch is fully seated.

**Binary/Trinary & Compressor:**  
*Binary Switch:* Terminate provided insulated female terminal (PN 23172-VUW) to the blue 16 AWG wire. Connect as shown.  
*Trinary Switch:* Connect according to trinary switch wiring diagram.



**Battery Connections:**  
*ECU Ground:* Terminate provided ring terminal (PN 226110) to 20 AWG white wire from the 231505 wire assembly and install at battery.  
*ECU PWR:* Terminate provided fuse assembly with black leads (PN 233012) to the 16 AWG red wire from the 231505 wire assembly. Install provided 10A Red Mini Fuse (PN 226118). Install at battery.  
*Blower Speed Controller (BSC) Ground:* Terminate provided ring terminal (PN 226111) to 12 AWG white wire from the 232020 wire assembly and install at battery.  
*Blower Speed Controller (BSC) PWR:* Terminate provided fuse assembly with orange leads (PN 233008) to the 12 AWG orange wire from the 232020 wire assembly. Install provided 30A Green ATO/ATC Fuse (PN 226125). Install at battery.





www.vintageair.com

## Operation of Controls

On Gen IV or Gen 5 systems with three lever/knob controls, the temperature control toggles between heat and A/C operations. To activate A/C, move the temperature lever/knob all the way to cold and then back it off to the desired vent temperature. For heat operation, move the temperature lever/knob all the way to hot and then adjust to the desired vent temperature. The blower will momentarily change speed, each time you toggle in and out of heat and A/C operations, to indicate the change.

### Blower Speed

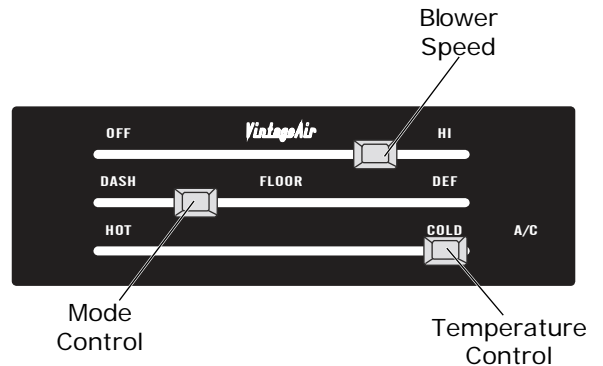
This lever/knob controls blower speed, from OFF to HI.

### Mode Control

This lever/knob controls the mode positions, from DASH to FLOOR to DEFROST, with a blend in between.

### Temperature Control

This lever/knob controls the temperature, from HOT to COLD.



## A/C Operation

### Blower Speed

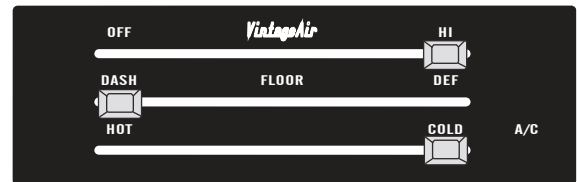
Adjust to desired speed.

### Mode Control

Adjust to desired mode position (DASH position recommended).

### Temperature Control

For A/C operation, adjust to coldest position to engage compressor (adjust between HOT and COLD to reach desired temperature).



## Heat Operation

### Blower Speed

Adjust to desired speed.

### Mode Control

Adjust to desired mode position (FLOOR position recommended).

### Temperature Control

For maximum heating, adjust to hottest position (adjust between HOT and COLD to reach desired temperature).



## Defrost/De-fog Operation

### Blower Speed

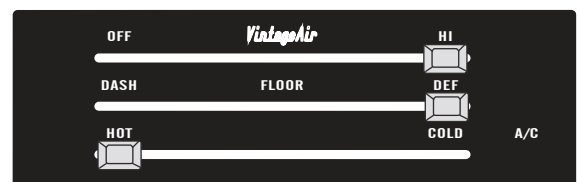
Adjust to desired speed.

### Temperature Control

Adjust to desired temperature.

### Mode Control

Adjust to DEFROST position for maximum defrost, or between FLOOR and DEFROST positions for a bi-level blend (Compressor is automatically engaged).





www.vintageair.com

# Troubleshooting Guide

This printed troubleshooting guide is our basic guide that covers common installation problems. To see our advanced diagnostics and troubleshooting guide, please refer to the following page for instructions on how to download the complete guide.

**WARNING: While troubleshooting the system, never probe connector terminals from the front mating side, only back probe.**

**WARNING: While troubleshooting the system, never use automotive check lights.**

Symptom	Condition	Checks	Actions	Notes
1. Blower stays on high speed with ignition on.	No other functions work.	Check for damaged pins or wires in the control panel wire assembly and mating header at ECU.	If found damaged, replace wire assembly or ECU.	If fuse continues to blow, there is a serious problem in the wiring. Check all wiring and ensure the wire is not damaged and shorting out along its route.
	All other functions work.	Check for a bad ECU GND. Check for damaged pins or wires in the control panel wire assembly and mating header at ECU. Check if Blower power fuse is blown. Check for a bad ECU GND.	If found damaged, replace wire assembly or ECU. Replace fuse. Repair connection.	
2. Compressor will not turn on (All other functions work).	System is not charged.	System must be charged for compressor to engage.	Charge system.	<b>Danger: Never bypass safety switch with engine running. Serious injury can result.</b>
	System is charged.	Check for faulty A/C potentiometer or associated wiring (not applicable to 3-pot controls).	Check continuity to ground on white control head wire. Check for 5V on red control head wire.	To check for proper pot function, check voltage at white/red wire. Voltage should be between 0V and 5V, and will vary with pot lever position.
		Check for disconnected or faulty thermistor.	Check 2-pin connector at ECU housing.	Disconnected or faulty thermistor will cause compressor to be disabled.
3. Compressor will not turn off (All other functions work).	Compressor will not turn off (All other functions work).	Check for faulty A/C potentiometer or associated wiring.	Repair or replace pot/control wiring.	Red wire at A/C pot should have approximately 5V with ignition on. White wire will have continuity to chassis ground. White/Red wire should vary between 0V and 5V when lever is moved up or down.
		Check for faulty A/C relay.	Replace relay.	



www.vintageair.com

# Troubleshooting Guide (Cont.)

Symptom	Condition	Checks	Actions	Notes
4. System will not turn on, or runs intermittently.	Works when engine is not running; shuts off when engine is started	Noise interference from either ignition or alternator.	Install capacitors on ignition coil and alternator. Ensure good ground at all points. Relocate coil and associated wiring away from ECU and ECU wiring. Check for burned or loose plug wires.	Ignition noise (radiated or conducted) will cause the system to shut down due to high voltage spikes. If this is suspected, check with a quality oscilloscope. Spikes greater than 16V will shut down the ECU. Install a radio capacitor at the positive post of the ignition coil (see radio capacitor installation bulletin). A faulty alternator or worn out battery can also result in this condition.
	Will not turn on under any conditions.	Verify connections on power lead, ignition lead, and both white ground wires. Verify battery voltage is greater than 10 volts and less than 16 while engine is running.	Check for power at ECU, and confirm ignition is being applied to ECU properly. Verify proper meter function by checking the condition of a known good battery.	
5. Loss of mode door function.	No mode change at all.	Check for damaged mode switch or potentiometer and associated wiring.		
	Blower turns on and off rapidly.	Battery voltage is at least 12V. Battery voltage is less than 12V.	Ensure all system grounds and power connections are clean and tight. Charge battery.	System shuts off blower at 10V. Poor connections or weak battery can cause shutdown at up to 11V.
7. Erratic functions of blower, mode, temp, etc.		Check for damaged switch or pot and associated wiring.	Repair or replace.	

## Advanced Diagnostics and Troubleshooting Guide

If after referencing the Troubleshooting Guide, the issue is not resolved, move to The Advanced Diagnostics and Troubleshooting Guide that covers the following:

- **ECU Diagnostics Codes**
  1. **ECU Blink Sequence**
  2. **Firmware Version Number**
  3. **ECU Model Number**
  4. **ECU Start-Up Blink Sequence**
  5. **Diagnostic Codes**
- **Complete Advanced Troubleshooting Guidelines**

Access the latest version of the Advanced Diagnostics and Troubleshooting Guide by scanning the following QR code on your mobile device:



You can also access the guide by typing the following address into your web browser:

[https://www.vintageair.com/instructions\\_pdf/905000.pdf](https://www.vintageair.com/instructions_pdf/905000.pdf)



www.vintageair.com

## Packing List: Evaporator Kit (564450)

No.	Qty.	Part No.	Description
1.	1	765200	Gen 5 Magnum Max Module _____
2.	1	784450	Accessory Kit _____

**\*\* Before beginning installation, open all packages and check contents of shipment. Please report any shortages directly to Vintage Air within 15 days. After 15 days, Vintage Air will not be responsible for missing or damaged items.**



**Gen 5 Magnum  
Max Module  
765200**

Checked By: \_\_\_\_\_  
Packed By: \_\_\_\_\_  
Date: \_\_\_\_\_

## Packing List: Evaporator Kit (564451)

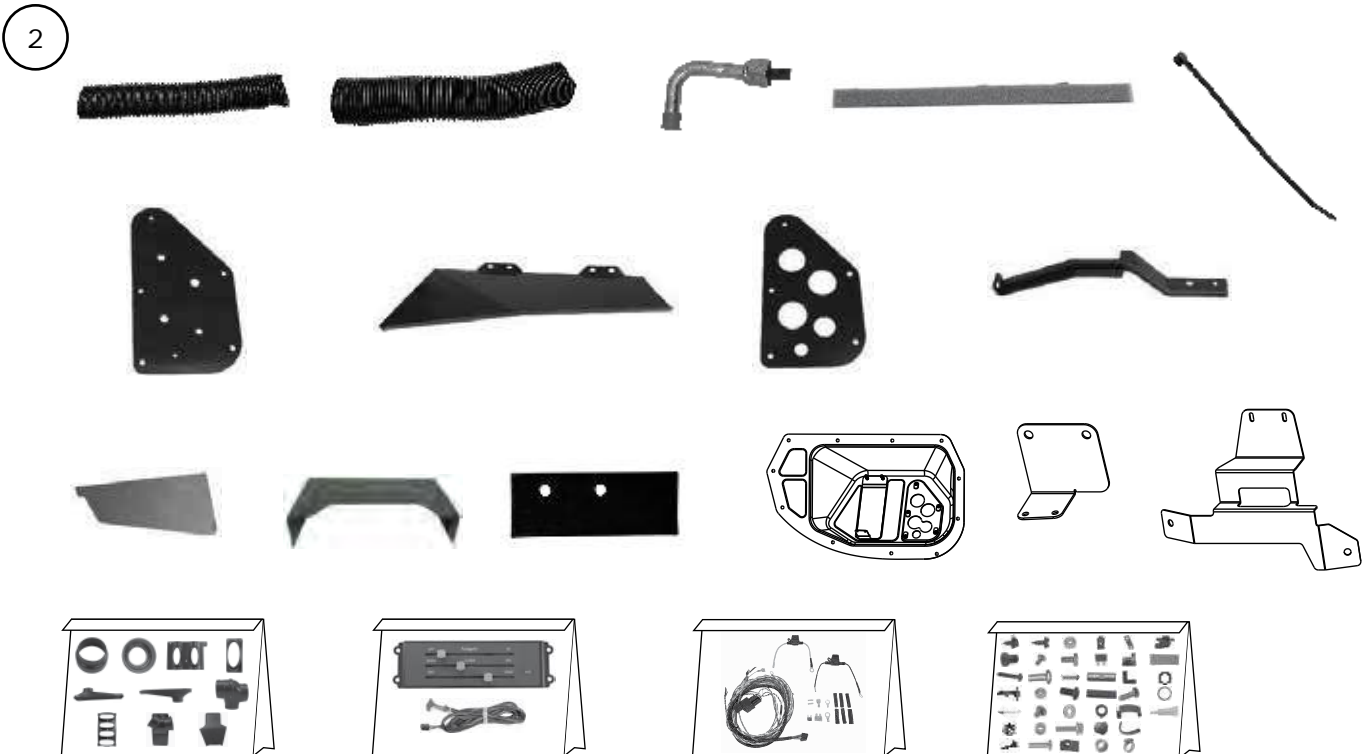
No.	Qty.	Part No.	Description
1.	1	765100	Gen 5 Magnum Module _____
2.	1	784450	Accessory Kit _____

**\*\* Before beginning installation, open all packages and check contents of shipment. Please report any shortages directly to Vintage Air within 15 days. After 15 days, Vintage Air will not be responsible for missing or damaged items.**



**Gen 5 Magnum  
Module  
765100**

Checked By: \_\_\_\_\_  
Packed By: \_\_\_\_\_  
Date: \_\_\_\_\_



**Accessory Kit  
784450**

**NOTE: Images may not depict actual parts and quantities.  
Refer to packing list for actual parts and quantities.**