



Part # 11280197

Part # 11280197 - 1965-1970 GM "B" Body Air Suspension System

Recommended Tools

Front Components:

11281010 Front CoolRide with HQ Series Shocks

Rear Components:

11284010 Rear CoolRide with HQ Series Shocks

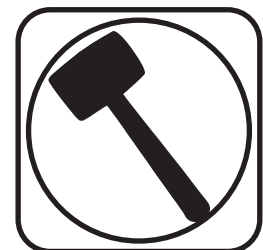
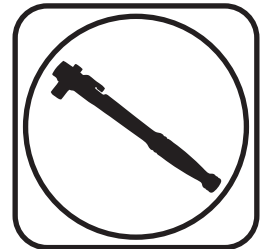

1965-1970 GM "B" Body Air Suspension Installation Instructions

Table of contents

Pages 2-6..... Front CoolRide
Pages 9-13..... Rear CoolRide

THIS COOLRIDE KIT IS DESIGNED TO BE USED WITH OEM CONTROL ARMS.





Part # 11281010

1965-1970 Full Size Chevy Car FRONT CoolRide Air Spring Kit with HQ Series Shocks



Recommended Tools

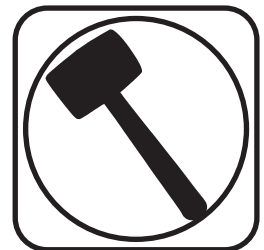
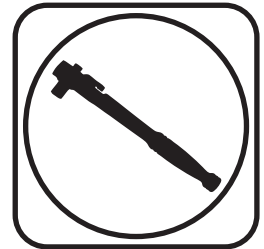

1965-1970 Full Size Chevy CoolRide Air Spring Kit Installation Instructions

Table of contents

- Page 3..... CoolRide Kit Components & Hardware List
- Page 4..... Getting Started
- Page 4-5..... Installing CoolRide
- Page 6..... Installing Shock

THIS COOLRIDE KIT IS DESIGNED TO BE USED WITH OEM CONTROL ARMS.



CoolRide Kit ComponentsIn the box

Item #	Part Number	Description	QTY
1	90000052	Upper Air Spring Cup Bracket	2
2	90006781	6.5" Diameter Air Spring	2
3	90000408	Lower Air Spring Plate - Driver - Shown	1
3	90000409	Lower Air Spring Plate - Passenger	1
4	90000011	Upper shock Bracket	2
5	986-10-036	4.75" Eyelet Top HQ Series Shock	2
6	70011138	3/4" ID Shock Bushing	4
7	90002102	1/2" ID x 1.312" Shock Sleeve	2
8	90002103	5/8" ID x 1.312" Shock Sleeve	2
9a	90001617 kit	Shock Stud - 70002825	2
9b	90001617 kit	5/8" SAE Flat Washer - 99623004	6
9c	90001617 kit	7/16" SAE Flat Washer - 99433002	2
9d	90001617 kit	5/8"-18 Lock Nut - 99622003	2
9e	90001617 kit	7/16"-14 Nylok Nut - 99432002	2

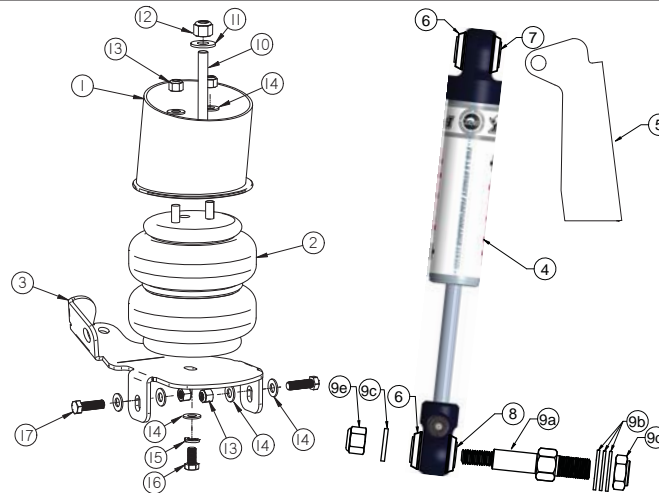

CoolRide Hardware.....In the box

Item#	Part Number	Description	QTY	Item #	Part Number	Description	QTY
UPPER AIR SPRING MOUNTING				LOWER AIR SPRING MOUNTING			
4	99435002	7/16"-14 x 8" Stud	2	10	99371001	3/8"-16 X 3/4" Bolt	2
5	99433002	7/16" Flat Washer	2	LOWER AIR SPRING PLATE			
6	99432001	7/16"-14 Nylok Nut	2	8	99372002	3/8"-16 Nylok Nut	4
7	99372002	3/8"-16 Nylok Nut	4	9	99373003	SAE Flat Washer	8
8	99373003	3/8" SAE Flat Washer	4	11	99371004	3/8"-16 X 1 1/4" Hex Bolt	4
LOWER AIR SPRING MOUNTING				UPPER SHOCK MOUNTING			
8	99373003	3/8" SAE Flat Washer	2		99501003	1/2"-13 X 2 1/2" Hex Bolt	2
9	99373005	3/8" Split Lock Washer	2		99502001	1/2"-13 Nylok Nut	2



Getting Started.....

THIS KIT IS DESIGNED TO BE USED WITH OEM CONTROL ARMS.

1. Raise and support car at a safe, comfortable working height. Let the front suspension hang freely
2. Remove coil spring and shock absorber. Refer to factory service manual for proper disassembly procedure.
3. Apply thread sealant to the air fitting and screw it into the top of the air spring.

Installing CoolRide



4. Assemble the upper cup bracket to the air spring, using 3/8"-16 Nylok nuts and 3/8" flat washers. Torque the 3/8" nuts 15-20 ftlbs.



5. Thread the 8" stud into the nut in the bottom of the cup.



Installing CoolRide



6. Place the lower air spring plate onto the lower control arm as shown in the picture. This is the Drivers side with the shock mount to the rear of the control arm. The plate will index off the rear strut arm bolt. The other two holes must be drilled for 3/8" x 1 1/4" bolts. Install flat washers and nylok nuts. Torque to 30 ft-lbs



7. The coil spring pocket will need to be trimmed for air spring clearance as shown in the picture. Install the air spring assembly into the coil spring pocket with the all thread protruding through the factory shock hole. The fitting access hole (tall side of bracket) will be clocked towards the outer tie rod end. Fasten with 7/16" Nylok and flat washer. The airline must be routed at this time. Torque 25-35 ft-lbs.



8. Secure the air spring to the lower plate use a 3/8" x 3/4" bolt, lock washer, and flat washer. Torque the 3/8" nuts 15-20 ftlbs.

9. Reattach the tie rod, spindle, and sway bar. Refer to a factory service manual for proper assemble procedure. The sway bar end link may be shortened to achieve proper clearance. This can be done by shortening the end link and bolt.

11. Double check the air spring clearance through full suspension travel. This air spring should be approximately 5" tall at ride height. This should be around 100psi.

IT IS THE FINAL RESPONSIBILITY OF THE INSTALLER TO MAKE SURE THE AIR SPRING DOES NOT RUB ON ANYTHING AT ANYTIME!!!



Installation



1. The upper shock mount must be welded to the frame. It may need to be cut down to match the stroke of the air spring and suspension. Make sure that when the suspension is fully compressed the shock is about $\frac{1}{4}$ " from being fully compressed. Just tack weld the mount for now and install the lower shock stud and shock. The upper mount will use a $2 \frac{1}{2}$ " x $\frac{1}{2}$ " bolt and nyloc. Check to make sure the shock does not bottom out when the suspension is fully compressed. If the shock bottoms out it could damage the shock or shock mounts.



2. Install a shock stud in the provision of the lower air spring mount. Use **Images 2a & 2b** as a guide for assembling the shock stud/shock.

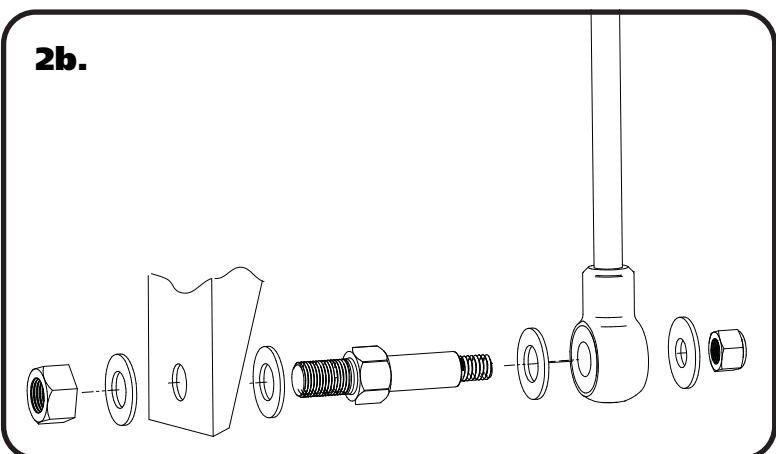



Part # 11284010

1965-1970 Full Size Chevy Car REAR CoolRide Air Spring Kit with HQ Series Shocks



Recommended Tools

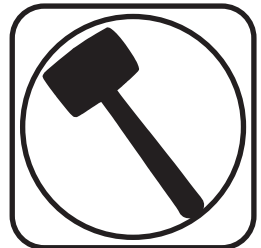

1965-1970 Full Size Chevy CoolRide Air Spring Kit Installation Instructions

Table of contents

- Page 8..... CoolRide Kit Components
- Page 9..... Hardware List & Getting Started
- Page 10-12..... Installing CoolRide
- Page 12..... Shock Adjustment

THIS COOLRIDE KIT IS DESIGNED TO BE USED WITH OEM CONTROL ARMS.



CoolRide Kit ComponentsIn the box

Item #	Part Number	Description	QTY
1	90000024	Upper Air Spring Cup Bracket	2
2	90006781	6.5" Diameter AirSpring	2
3	90000070	Lower Air Spring Roll Plate	2
4	90000224	Large Upper Washer - may not be needed	2
5	986-10-020	7.55" HQ Series Shock Assembly	2
6	90001619	Cantilever PIN Bolt Kit	2
7	70011139	5/8" ID Shock Bushing	2
8	90002068	Extended Trunnion	2
9	70011138	3/4" ID Shock Bushing	2
10	90002102	1/2" ID x 1.312" Shock Sleeve	2

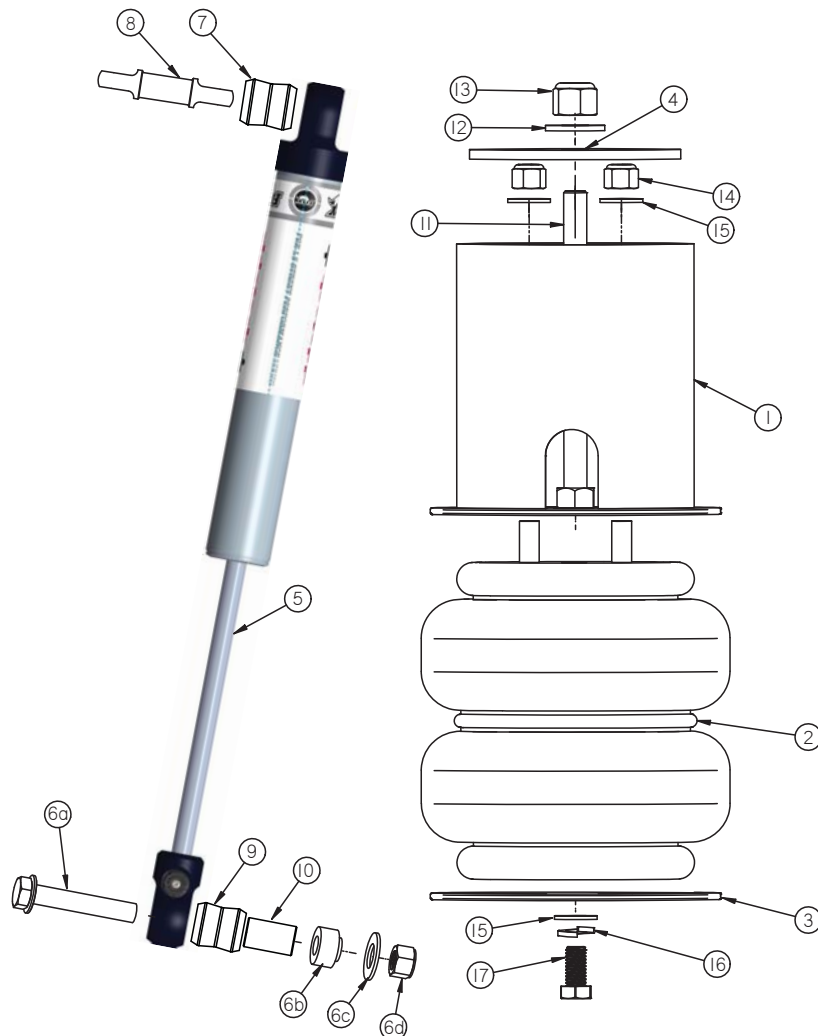



CoolRide Hardware Kits.....In the box

Kit # 99010120				Kit # 99010119			
Item #	Part Number	Description	QTY	Item #	Part Number	Description	QTY
UPPER AIR SPRING MOUNTING				SHOCK HARDWARE			
11	99435001	7/16"-14 x 6" Stud	2		99311001	5/16"-18 X 1" Hex Bolt	4
12	99432001	7/16"-14 Nylok Nut	2		99312003	5/16"-18 Nylok Nut	4
13	99433002	7/16" Flat Washer	2		99313002	5/16" SAE Flat Washer	8
14	99372002	3/8"-16 Nylok Nut	4				
15	99373003	SAE Flat Washer	4				
LOWER AIR SPRING MOUNTING							
15	99373003	3/8" SAE Flat Washer	2				
16	99373005	3/8" Split Lock Washer	2				
17	99371001	3/8"-16 X 3/4" Hex Bolt	2				

Getting Started.....

THIS COOLRIDE KIT IS DESIGNED TO BE USED WITH OEM CONTROL ARMS.

1. Raise and support vehicle at a safe and comfortable working height.
2. Support axle then remove coil spring, and shock. Refer to service manual for proper disassembly procedure.
3. Apply thread sealant to the air fitting and screw it into the air spring.

Installing CoolRide



4. Apply thread sealant to the air fitting and screw it into the air spring. Assemble the upper cup bracket to the air spring, using 3/8"-16 Nylok nuts and 3/8" flat washers. Torque the 3/8" nuts 15-20 ftlbs.



Installing CoolRide



5. Thread the 6" stud into the nut in the bottom of the cup.



6a & 6b The large washer needs to be installed on the TOP side of the frame at the coil spring pocket.



6b. The washer needs to be center on the upper opening.



Installing CoolRide



7. Place the air spring assembly into the coil spring pocket with the tab on the side of the cup aligning with the factory bump stop mount. The stud should poke through the hole in the upper coil spring pocket. Some cars may not have this hole and it must be drilled with a 7/16" drill bit. Fasten with a 7/16" Nylok nut and flat washer. Torque 25-35 ft-lbs.



8. Slide the lower plate between the air spring and the lower arm. It is held tight with a 3/8" x 3/4" bolt with flat washer and lock washer. Torque the 3/8" bolt to 15-20 ftlbs.

Install the Ridetech HQ Series Shock kit #11280701.



9. Attach shock T-Bar to frame using 5/16" x 1" bolts, Nylok nuts and flat washers. Torque to 17 ft-lbs.



Installing CoolRide

10.

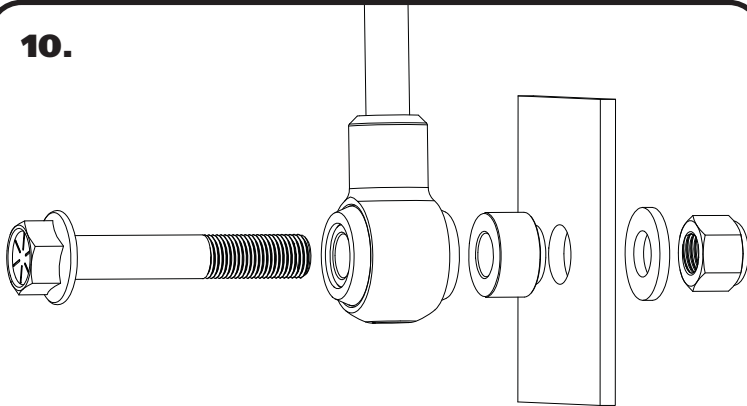

10. Attach the shock to the axle using the new shock bolt kit supplied. Use **Diagram 10** as a reference for assembly. Torque to 75 ft-lbs.

11. This air spring should be approximately 5" tall at ride height.

IT IS THE FINAL RESPONSIBILITY OF THE CUSTOMER TO ENSURE THAT THE AIR SPRING DOES NOT RUB ON ANYTHING AT ANYTIME!!

Shock Adjustment

Shock adjustment 101- Single Adjustable

Rebound Adjustment:

How to adjust your new shocks

The rebound adjustment knob is located on the top of the shock absorber protruding from the eyelet or stud top. You must first begin at the ZERO setting, then set the shock to a street setting of 12 or handling setting of 8.



-Begin with the shocks adjusted to the ZERO rebound position (full stiff). Do this by rotating the rebound adjuster knob clockwise until it stops.

-Now turn the rebound adjuster knob counter clockwise 12 clicks. This sets the shock at 12 for a street setting. If you are after a handling setting only go 8 clicks.

Take the vehicle for a test drive.



-if you are satisfied with the ride quality, do not do anything, you are set!

-if the vehicle is too soft increase the damping effect by rotating the rebound knob clockwise 3 additional clicks.

-If the vehicle is too stiff rotate the rebound adjustment knob counter clock wise 2 clicks and you are set!

Take the vehicle for another test drive and repeat the above steps until the ride quality is satisfactory.

Note:

One end of the vehicle will likely reach the desired setting before the other end. If this happens stop adjusting the satisfied end and keep adjusting the unsatisfied end until the overall ride quality is satisfactory.