

ridetech



350 S. St. Charles St. Jasper, In. 47546
Ph. 812.482.2932 Fax 812.634.6632

www.ridetech.com



Part # 11329599 – G Body /11399599 – S10 78-88 GM “G” Body/82-03 S10 Tru-Turn Suspension Package

Front Components:

1	11323695	Upper Strong Arms
1	11322895	Lower Strong Arms
1	11329595/11399595	Tru Turn System

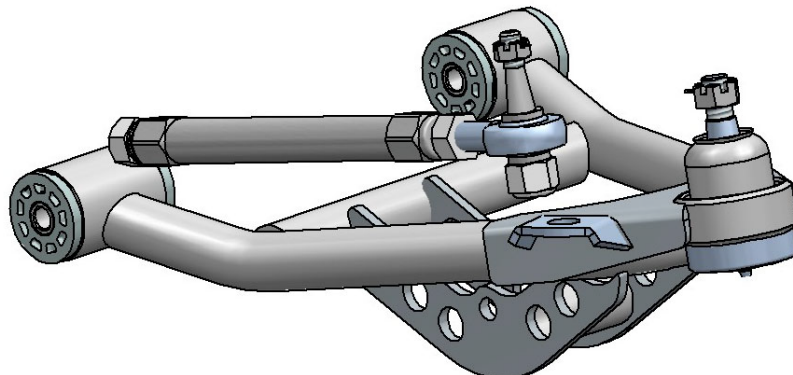
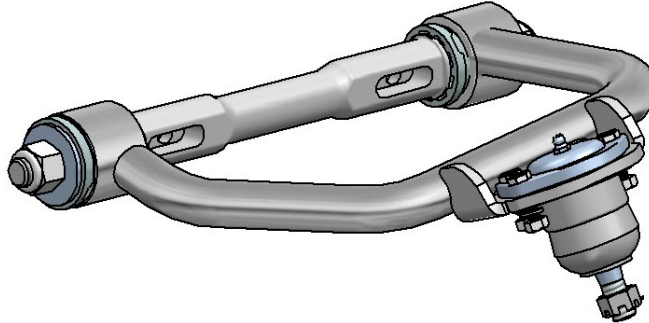



350 S. St. Charles St. Jasper, In. 47546
Ph. 812.482.2932 Fax 812.634.6632

www.ridetech.com

Part # 11323695
78-88 GM "G" Body/82-03 S10 Upper StrongArms

Components:

1	90002379	Drivers side arm
1	90002380	Passenger side arm
2	90000913	Upper ball joint – Proforged # 101-10020
2	90000914	Caster Adjustable Cross shaft w/Hardware
2	70010826	Delrin Bushing – no ledge
2	70010827	Delrin Bushing – small ledge
4	70010759	Delrin Bushing – outer
4	90002737	Cross shaft T-washer
4	70011955	Zero Offset Caster Slugs

Hardware:

4	99433004	7/16" USS Flatwasher	Cross shaft to Frame
4	99431009	7/16"-14 x 2 1/2" Bolt	Cross shaft to Frame
4	99432001	7/16"-14 Nylok Nut	Cross shaft to Frame

DUE TO THE SHANK OF THE BALL JOINT BEING LONGER, THE BALL JOINT BOOT IS DESIGNED TO SEAL ON THE BALL JOINT SHANK. IT DOES NOT SEAL AGAINST THE SPINDLE.

STRONGARMS



1. Fasten the upper arm to the frame using the supplied 7/16" hardware. Reinstall the current alignment shims, but **vehicle must be realigned**. Torque to 55 ft-lbs.

2. Drop ball joint down through upper arm. Slide ball joint boot over stud, then place boot retainer over the boot.

Torque Specs:

Upper Ball joint - 61 ftlbs and tighten to line up cotter pin.

3. Fasten the ball joint to the spindle w/ the new castle nut and cotter pin supplied.

4. Tighten the cross shaft nuts enough to create drag on the delrin bushings, the arm should still move.

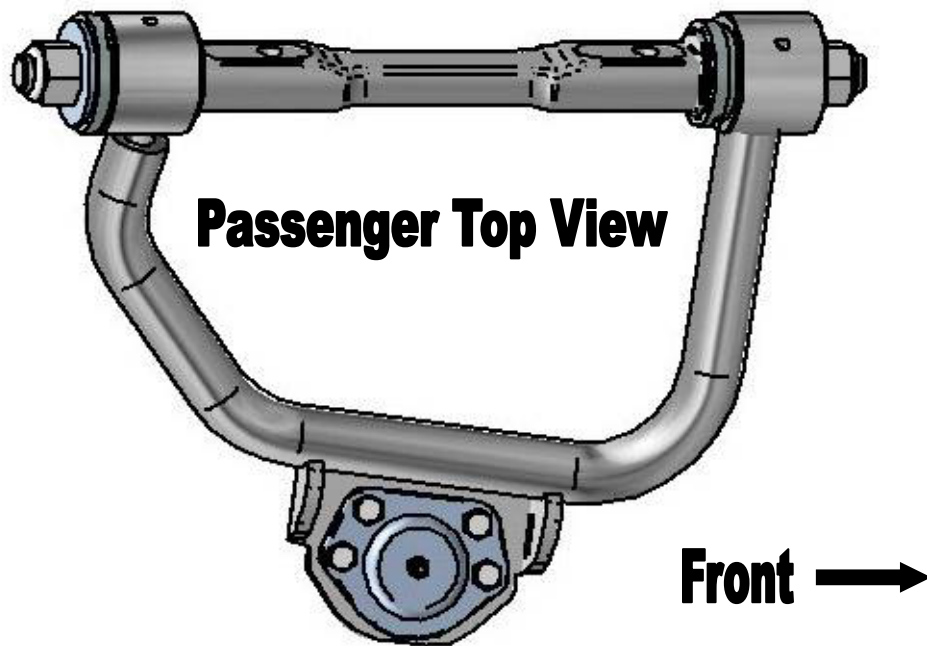

STRONGARMS

Passenger Side – Top View

Item #	Description	Qty.
1.	99622005 - 5/8 – 18 Toplock Jam Nut	4
2.	T-Washer	4
3.	Outer Delrin bushing	4
4.	Passenger side arm	1
4.	Driver side arm	1
5.	Inner Delrin bushing w/ledge	2
6.	Caster Adjustable Cross shaft	2
7.	Caster Slug	2
8.	Inner Delrin bushing no ledge	2

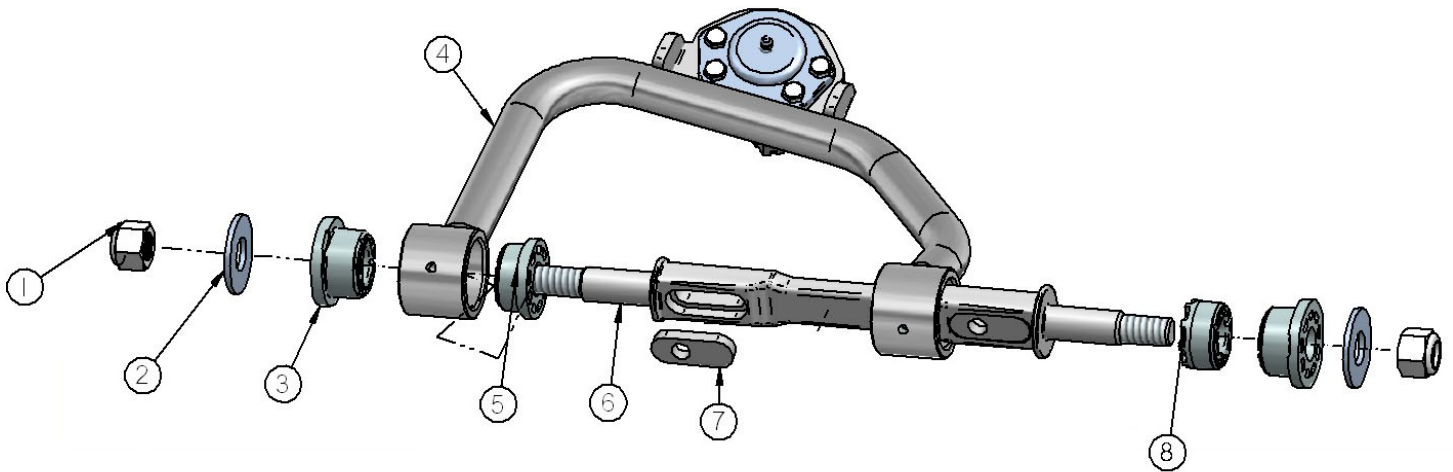

STRONGARMS

FRONT
→

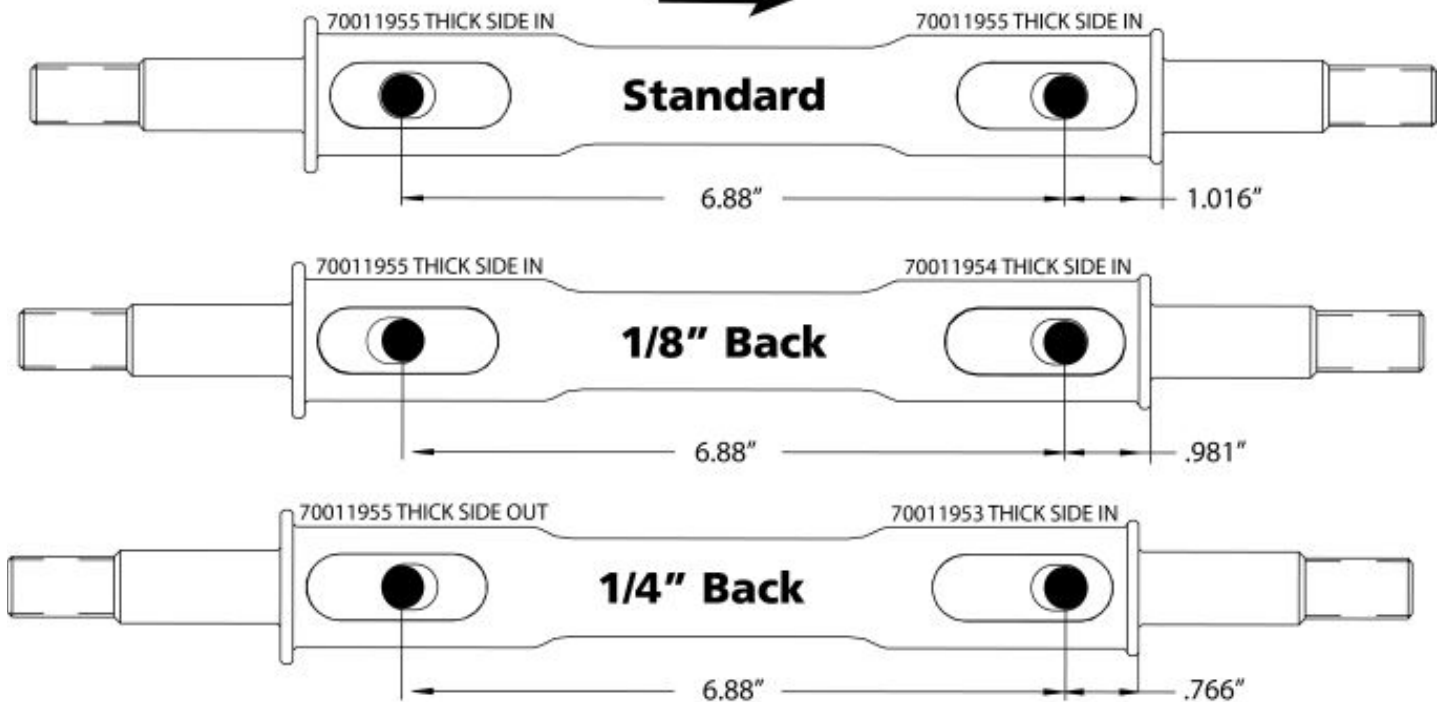

These StrongArms come equipped with a changeable caster slug setup. This allows you to add or remove caster from the front suspension, if desired. The caster slugs that come supplied in the kit are setup to be centered. The caster slugs allow you to add or remove caster without having to use a stack of shims. If more or less caster is desired, optional slugs can be purchased from Ridetech or your Ridetech dealer. The diagram above will help you determine what caster slug you may need if trying to achieve more caster. It will also show you how to position the caster slug.

STANDARD CAATER SKUGS INCLUDED IN KIT = 4 OF 70011955

CASTER SLUGS REQUIRED TO GET MORE CASTER

1/8" BACK = REQUIRES 2 OF 70011954

1/4" BACK = REQUIRES 2 OF 70011953

Caster Explained:

To understand caster you need to picture an imaginary line that runs through the upper ball joint and extends through the lower ball joint. From the side view the imaginary line will tilt forward or backward. The tilting of this imaginary line is defined as caster.

Caster is measured in degrees by using a caster camber gauge. If the imaginary line described above tilts towards the back of the car, at the top, then you will have positive caster. If the imaginary line tilts forward then you would have negative caster.

Positive caster provides the directional stability in your car. Too much positive caster will make the steering effort difficult. Power steering will allow you to run more positive caster. Negative caster requires less steering effort but can cause the car to wander down the highway.

STRONG ARMS

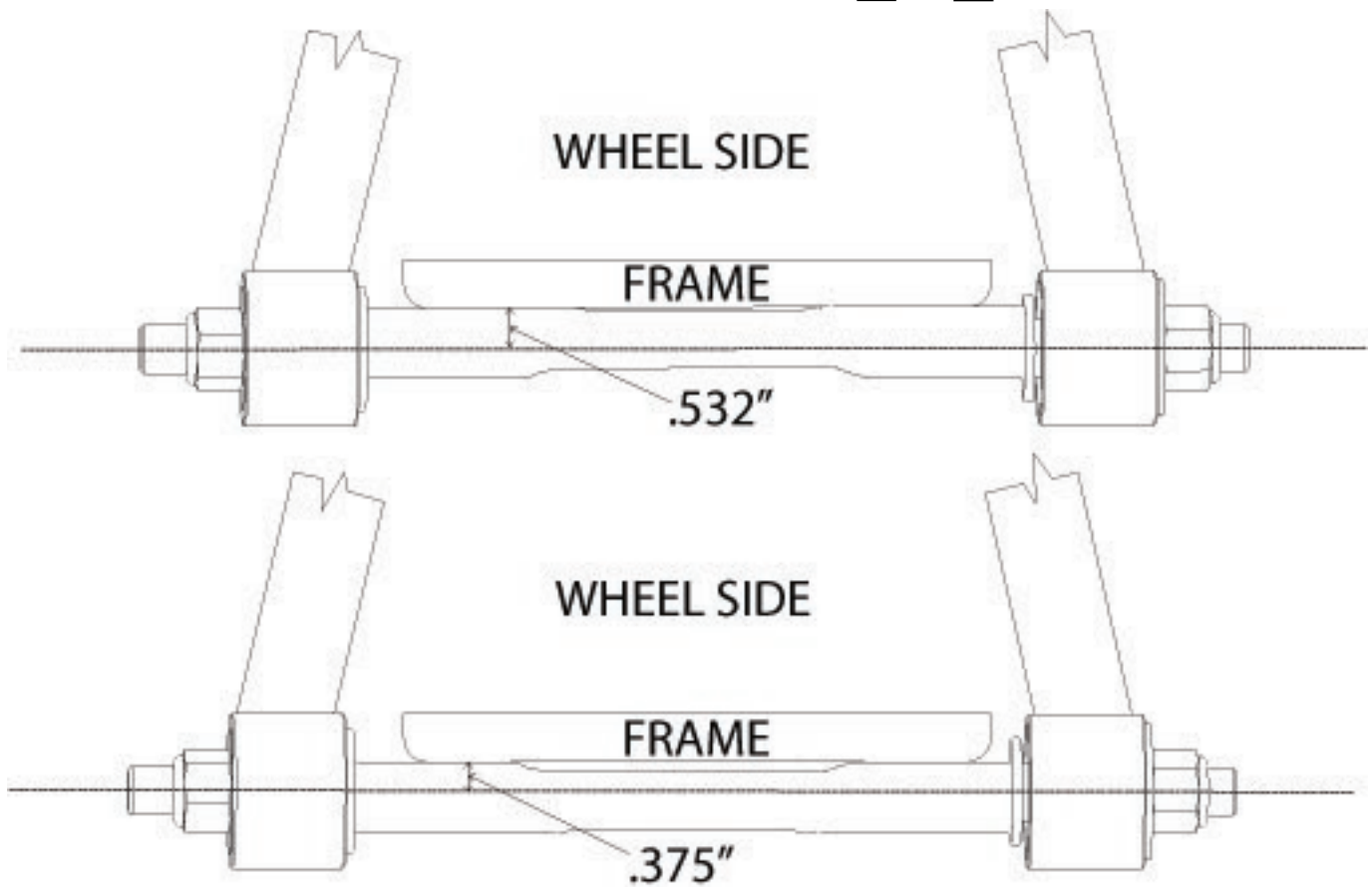

Offset Upper Cross Shaft

The cross shaft that is used in the upper control arm is offset. The offset combined with the caster slug option allows you to achieve the alignment setting you desire with minimal shims. To change the direction that the Icon faces, simply spin the cross shaft in the control arm.

If you are after an aggressive **Track or Autocross Alignment**, bolt the control arm to the frame bracket with the arm offset to the inside of the car (like the top illustration). The Ridetech Icon will be facing the engine.

If a **Street Alignment** is desired, bolt the control to the frame bracket with the arm offset to the outside of the car (like the bottom illustration). The Ridetech Icon will be facing the wheel.



350 S. St. Charles St. Jasper, In. 47546
Ph. 812.482.2932 Fax 812.634.6632

www.ridetech.com

Part # 11322895
78-88 GM "G" Body/82-03 S10 Lower StrongArms
For Use w/ Shockwaves or CoilOvers

Components:

1	90002377	Driver side lower arm
1	90002378	Passenger side lower arm
2	90000896	Ball joint – Proforged # 101-10049
2	90000572	Inner bushing sleeve -12mm x 2.375" - <i>installed in control arm</i>
2	90000573	Inner bushing sleeve -12 mm x 3.00"
2	90001094	Inner bushing sleeve – 14mm x 3.00" - <i>installed in control arm</i>
8	70010759	Delrin bushing half
4	90002062	Aluminum spacer – Shock to lower arm

Hardware: The hardware kit includes hardware for both the G-Body and the S10, be sure to use the correct hardware for your application.

2	99501005	½"-13 x 3 1/2" Gr.8 bolt	Shockwave to lower arm - BOTH
2	99502009	½"-13 Nylok nut	Shockwave to lower arm - BOTH
4	99503014	½" SAE Flat Washer	Shockwave to lower arm - BOTH
2	99121001	M12-1.75 X 90mm Bolt	StrongArm to Frame - BOTH
2	99121002	M12-1.75 X 110mm Bolt	StrongArm to Frame – G-BODY
4	99122001	M12-1.75 Nylok nut	StrongArm to Frame – (4) G-BODY/ (2)2 S10
4	99123002	M12 Flat Washer	StrongArm to Frame – (4) G-BODY/ (2)2 S10
2	99141003	M14-2.0 x 100mm Hex Bolt	StrongArm to Frame – S10
2	99142002	M14-2.0 Nylok Nut	StrongArm to Frame – S10
2	99143001	M14 Flat Washer	StrongArm to Frame – S10

STRONGARMS

Installation Instructions

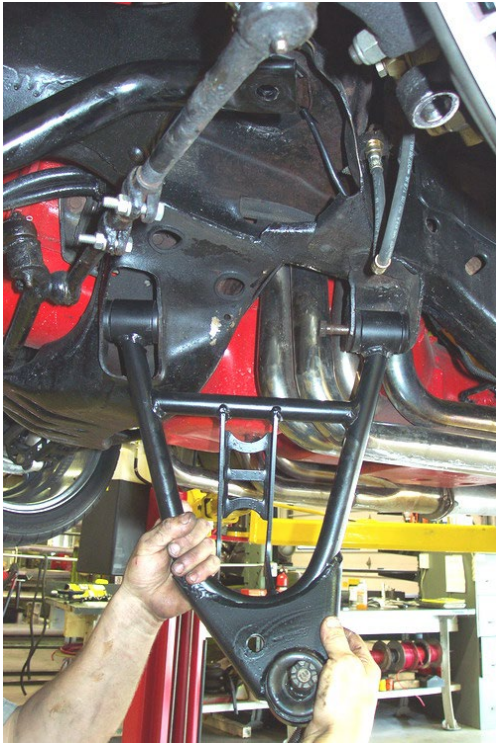

1. After removing the factory lower control arm, clean the bushing mounting surfaces on the frame to make sure they are fairly smooth.

NOTE: IF YOU ARE INSTALLING THESE CONTROLS ARMS ON A G-BODY, THE 3" LONG SLEEVE IN THE CONTROL ARM WILL NEED TO BE CHANGED TO THE 3" SLEEVE THAT IS INCLUDED SEPERATELY IN THE KIT.

2. Fasten the lower arm to the frame using the correct hardware that is supplied in the kit. G-Body uses (2) 12 mm bolts. S10 uses a 12mm and 14mm bolt to attach the control arm. Torque to 75 ft-lbs.

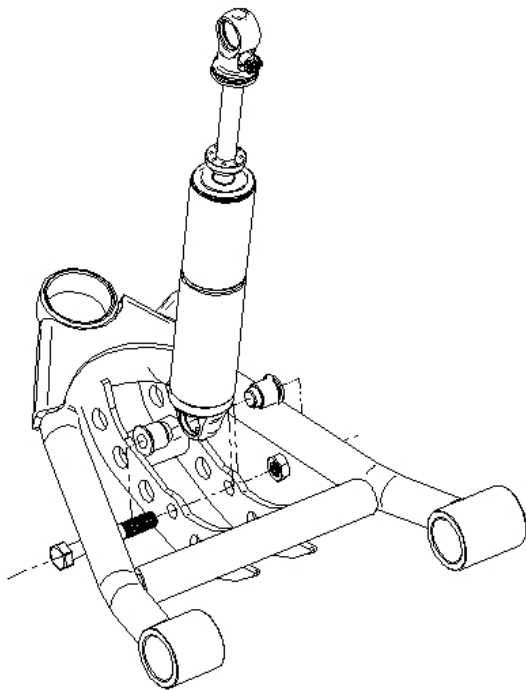

3. Swing the lower StrongArm up to the shock and secure with the $\frac{1}{2}$ " x 3 $\frac{1}{2}$ " bolt, flat washers, and Nylok nut. An aluminum spacer must be installed in each side of the bearing. The small diameter of the spacer will get inserted into the shock bearing. Torque to 75 ft-lbs.

4. Slide the ball joint boot over the stud, then push the stud up through the spindle.

Torque Specs:

Lower Ball joint - 79 ftlbs and tighten to line up cotter pin

5. Grease the ball joints.

STRONGARMS

Item #	Description	Qty.
1.	Driver side arm	1
2.	Ball Joint	1
3.	Inner bushing sleeve – narrow	1
4.	Inner bushing sleeve – wide	1
5.	Delrin bushing half	2
6.	Delrin bushing half	2
7.	Aluminum bearing spacer	2
8.	1/2"-13 x 3 1/2" bolt	1
9.	1/2"-13 Nylok nut	1
	1/2" SAE Flat Washer not shown	2

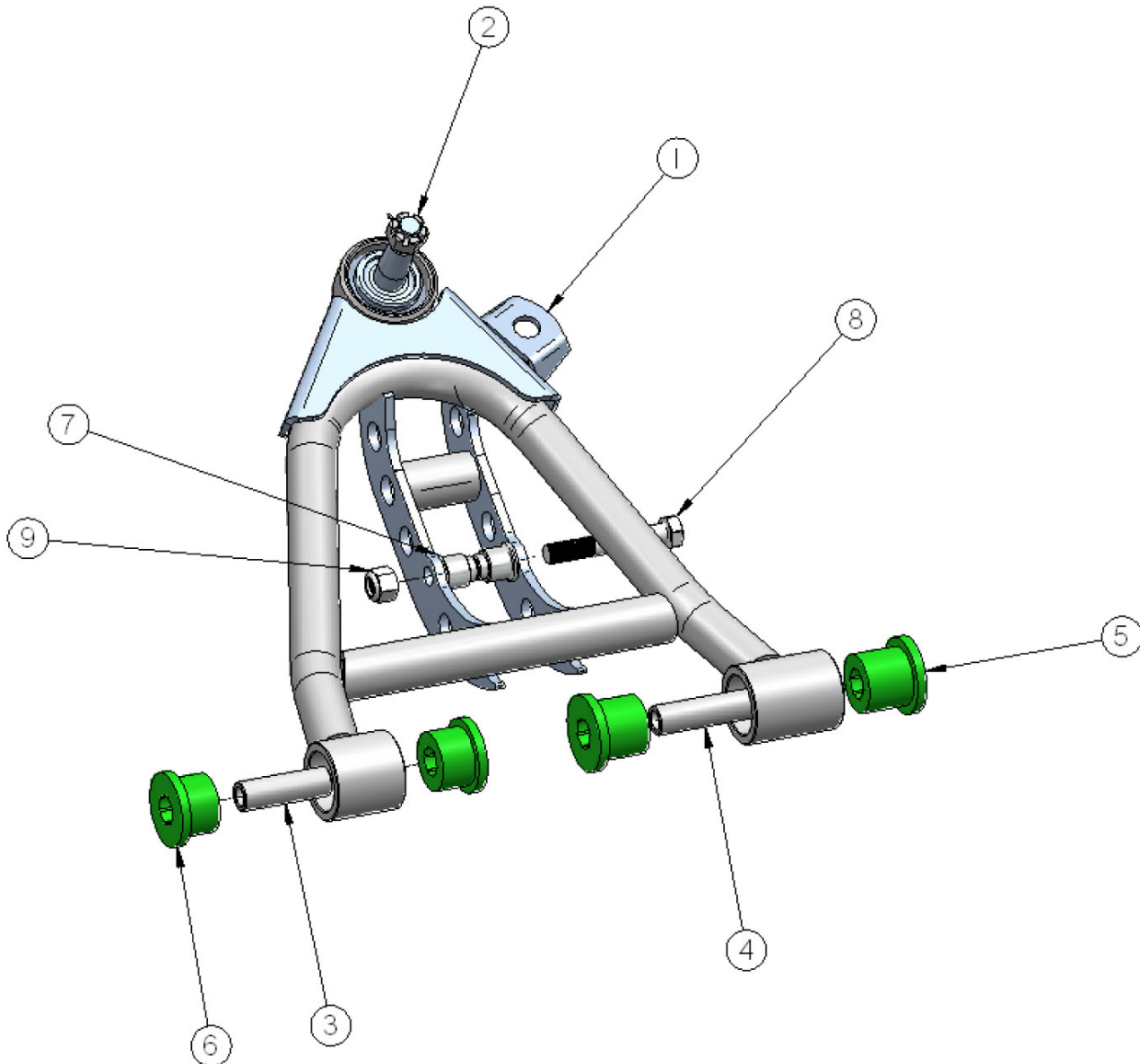



350 S. St. Charles St. Jasper, In. 47546
 Ph. 812.482.2932 Fax 812.634.6632
www.ridetech.com

Part # 11329595/11399595
78-88 G-Body/82-03 S10 TruTurn System without Spindles



Item #	Part #	Description-Specification	Qty.
1.	90001590	Heim end	2
2.	99800002	5/8"-18 RH jam nut	2
3.	90002676	Heim End Spacer	4
4.	99622003	5/8"-18 Lock Nut-35 ft lbs	2
5.	90002374	Tie Rod Stud	2
6.	99432005	7/16"-20 castle nut-35 ft lbs	2
7.	90002375	Adjusting sleeve	2
8.	99952002	3/32" cotter pin	2
9.	99800003	5/8"-18 LH jam nut	2
	90003058	Inner Tie Rod -S10 ONLY(not shown)	2

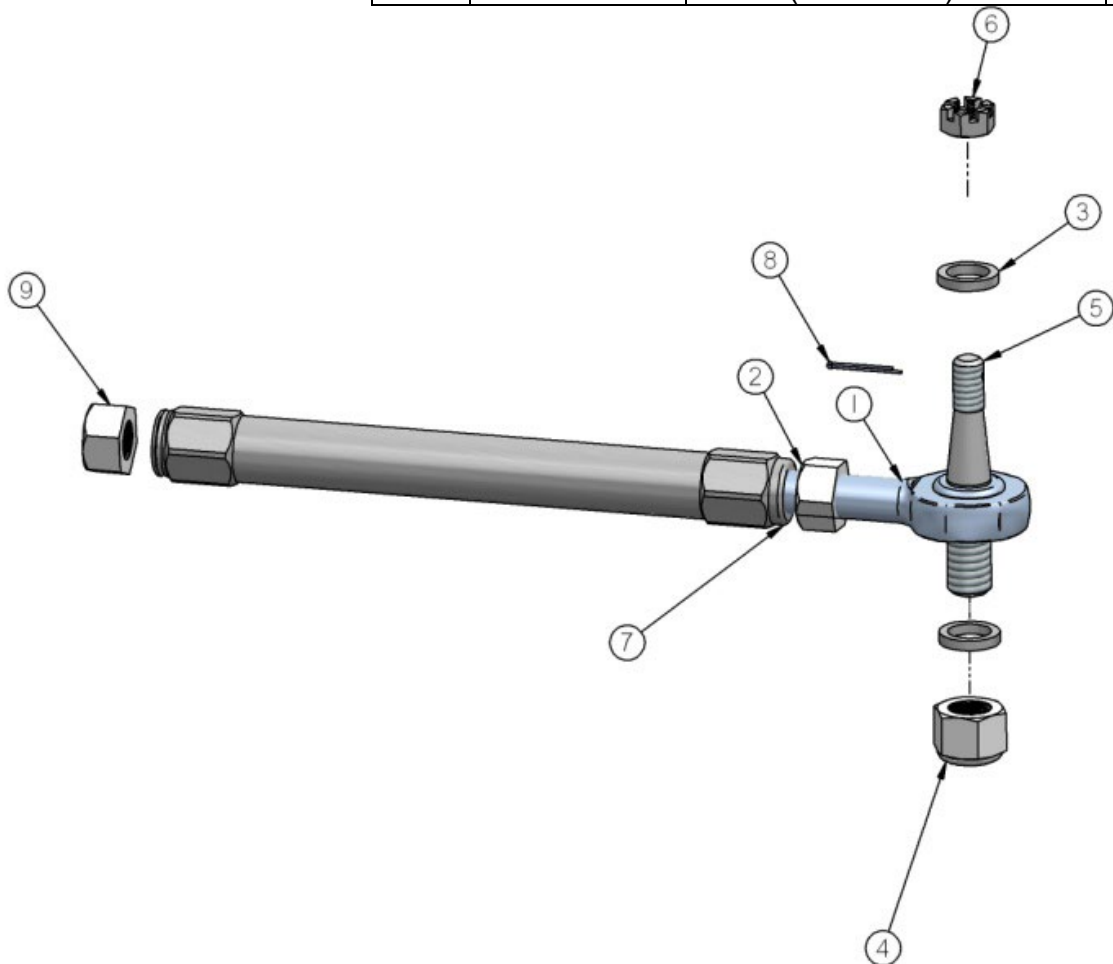



350 S. St. Charles Street Jasper, In. 47546 www.ridetech.com

Installation instructions:

IF INSTALLING A S10 KIT, IT WILL COME WITH NEW INNER TIE RODS!

NOTE: The number in (#) is the number of the part in the drawing on the previous page.

1. Raise and safely support the front of your vehicle at a comfortable working level
2. Remove existing outer tie rod and adjuster leaving the inner tie rod.
3. Install the (5) Tie Rod Stud into your factory spindle using the (6)7/16" castle nut. Torque the nut to 35 ft lbs and install (8) cotter pin. **NOTE:** If none of the holes line up tighten the nut until you can get the hole to line up with a slot.
4. Install the (7) Right Hand thread nut onto the (1) heim end and (9) Left hand nut onto the factory tie rod.
5. Antiseize the threads on the factory tie rod and heim end to prevent the threads from galling.
6. The left hand threaded side of the (7) adjuster goes onto the factory tie rod; it has a groove cut into the end of the adjuster. You will want the thread engagement the same on the tie rod end and the heim, the easy way to do this is set then nut on the tie rod 1 1/4" from the end of the tie rod and thread the adjuster on so that it touches the nut.
7. Install the heim end into the other end of the adjuster. Start by threading the lock nut all the way on the heim end and thread the heim end into the adjuster so that it touches the nut.
8. Install the heim end side of the tie rod onto the tie rod stud using the (3) aluminum spacer on top and bottom of the heim end and then install the (4)5/8" lock nut. Torque nut to 35 ft lbs.
9. Set the center to center length of the tie rod assembly to 17 3/4" by turning the adjuster out. This will get you close on the toe setting but it will need to be aligned. **USE THE SIGHT HOLES IN THE SIDE OF THE TIE ROD ADJUSTER TO ENSURE PROPER THREAD ENGAGEMENT.**
10. Adjust the camber and toe roughly until you can get the vehicle to a proper alignment shop. The recommended alignment settings are:

Camber - -.5 to -1.5 [within .3 from side to side]

Caster - 4 to 7 degrees positive

Toe - 1/16" to 1/8" toe in

Feel free to experiment with alternative alignment settings that may be more appropriate for your particular driving style.

Installation notes:

- A. **MAKE SURE** that the cotter pins are properly installed in all appropriate places [C] to ensure that the castle nuts do not become loose and fail. These are VERY important connections!