

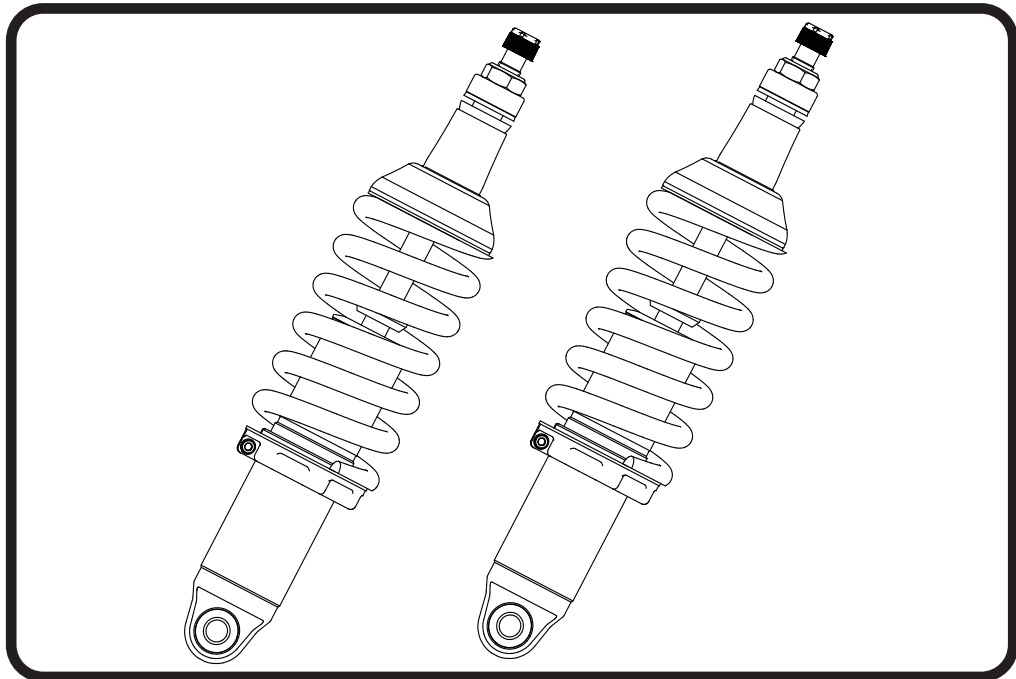

Part # 11393510 - 1982-2003 S10/S15 HQ Front CoilOvers

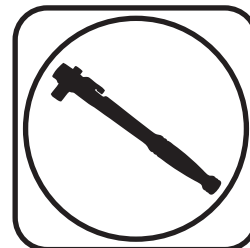

Recommended Tools

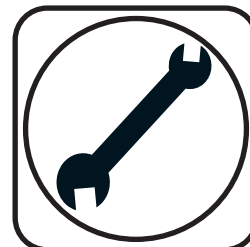

1982-2003 S10/S15 HQ Series Front CoilOvers

Installation Instructions

Table of contents

- Page 2..... Included Components
- Page 3..... CoilOver Assembly
- Page 4..... CoilOver Installation
- Page 5..... CoilSpring Adjusting
- Page 6..... Shock Adjustment

CoilOver Dimensions:

- Center of bearing to Stud Mounting Surface:
- Compressed: 9.73"
- Ride Height: 11.80"
- Extended: 13.33"



Major ComponentsIn the box

Item #	Part #	Description	QTY
1	982-10-803	3.6" Stroke HQ Series Shock	2
2	59080750	CoilSpring 8" 750lb	2
3	70010828	Delrin Spring Washer	4
4	803-00-199(kit)	Lower Spring Adjuster Nut (803-00-199 kit)	2
5	803-00-199(kit)	Adjuster Nut Locking Screw (803-00-199 kit)	2
6	90002070	Dropped Upper CoilSpring Retaining Plate	2
7	803-00-199(kit)	CoilSpring Plate Retaining Ring (803-00-199 kit)	2
8	90009988(kit)	2.00" Stud Adjuster Assembly	2
9	90002312	2.00" Stud Top Base	2
10	90001904	Delrin Ball Lower Half	2
11	90001903	Delrin Ball Top Half	2
12	90001902	Delrin Ball Upper Cap	2
13	99562003	9/16-18" Nylok Nut	2
14	210-35-120-0	Shock Adjuster Knob	2
15	90009969	Adjuster Knob Retaining Screw	2
	90001994	5/8" ID Bearing (installed in shock body)	2
	90001995	Bearing Snap Ring (installed in shock body)	4

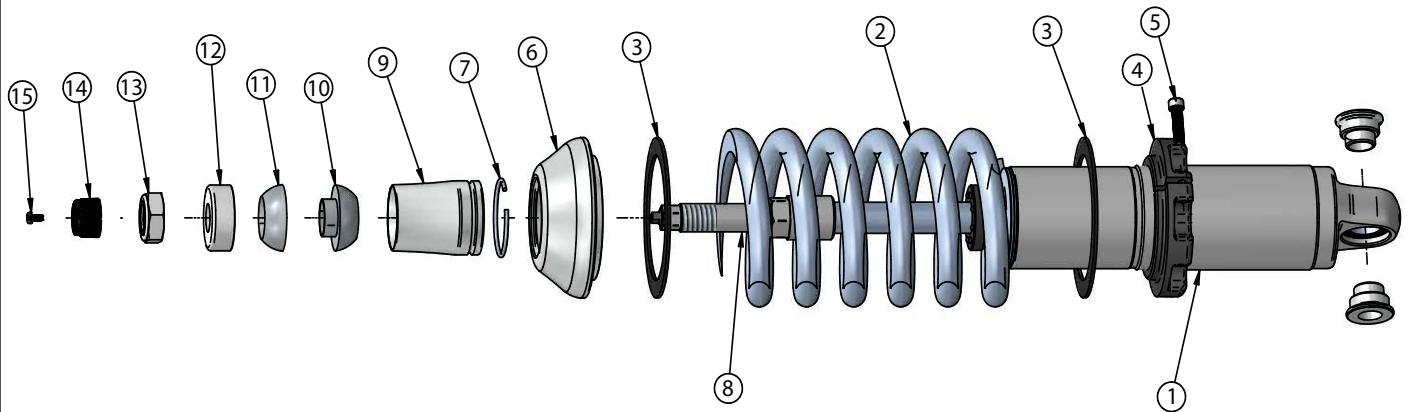



CoilOver Assembly

1.

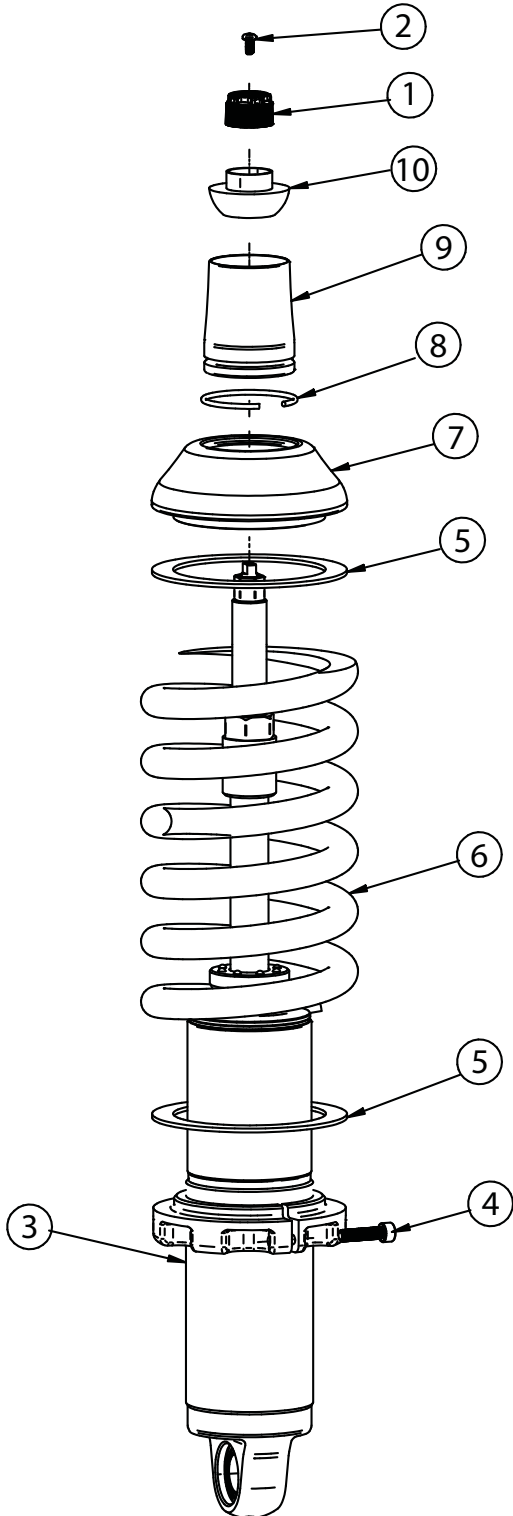

1. To Assemble the CoilOver you need to:
 - a. Remove Screw (2) from center of Adjustment Knob (1) and remove Adjustment Knob.
 - b. Remove Nylok Nut, Delrin Upper Cap, Delrin Upper and Lower Balls, along with the base from the Coliover stud.
 - c. Thread Adjuster Nut (3) onto the CoilOver body. Once it is threaded on the shock body, lightly thread in the locking screw (4) into the Adjuster Nut.
 - d. Install a Delrin Spring Washer (5) onto the Adjuster Nut.
 - e. Slide the CoilSpring (6) onto the CoilOver.
 - f. Install another Delrin Spring Washer (5) on top of the CoilSpring.
 - g. Install the Upper CoilSpring Plate (7) onto the CoilSpring.
 - h. Install the CoilSpring Retaining Ring (8) onto the Stud Top Base (9). It fits into the groove in the base.
 - i. Slide the Stud Top Base onto the shock until it bottoms out on the stud. It may be necessary to thread the Adjuster Nut down the shock body (to lower the spring) if the base will not slide all the way down onto the stud.
 - k. Slide the Lower Delrin Ball (10) (it has the collar sticking up around the center hole) on to the Stud Top.

Repeat on second CoilOver.



CoilOver Installation

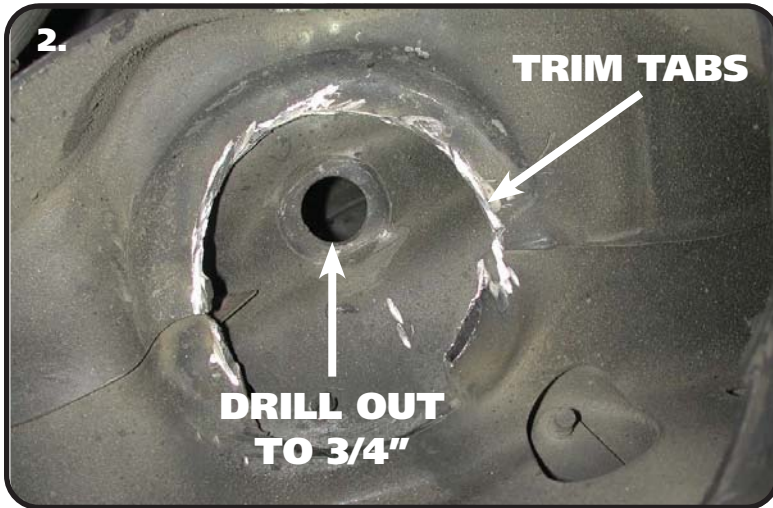

2. The factory shock hole will need to be drilled out to 3/4", this can best be done using a Unibit. The CoilSpring retaining tabs will need to be trimmed to keep them from hitting the CoilOver Spring Retainer.

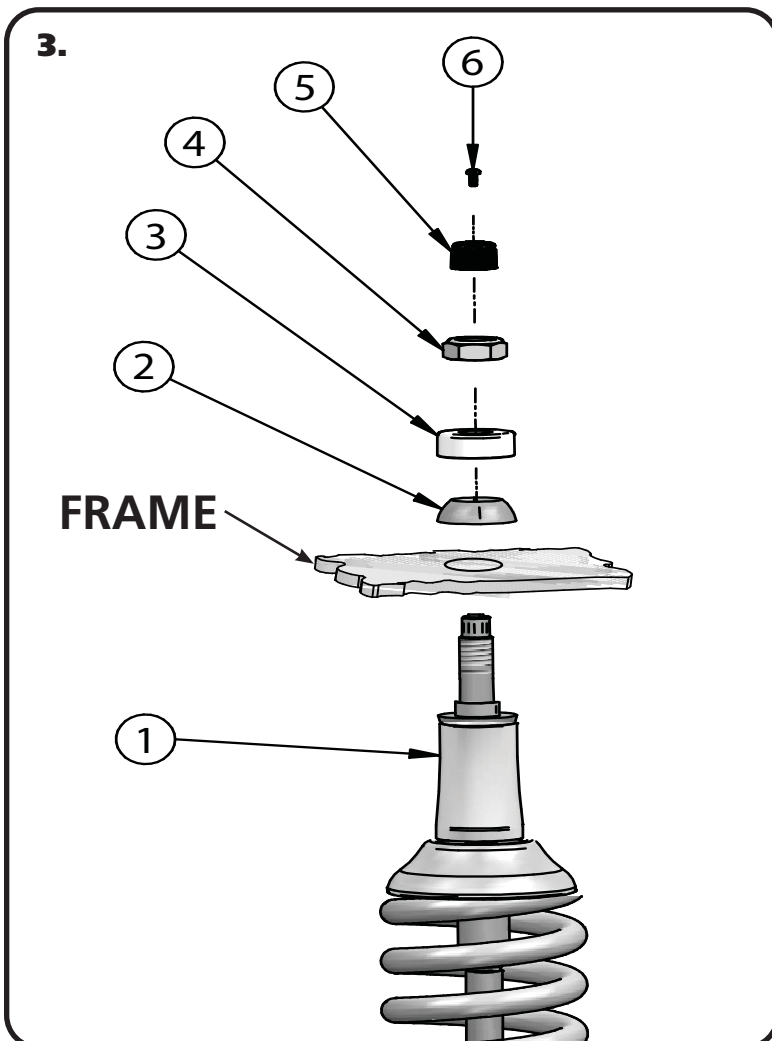

3. With the CoilOver(1) assembled, it is time to bolt them into the car. Insert the CoilOver Stud Top through the factory hole in the frame. Install the Upper Delrin Ball(2) onto the shock stud with the flat side facing the frame. Next, Install the Delrin Ball cap (3) onto the shock stud with the Concave side facing the Upper Delrin ball. Install the Nylok Nut(3) onto the shock stud and lightly tighten. There needs to be some resistance on the ball but not tight enough that it will not rotate freely. Reinstall the adjuster knob(5) using the screw (6) that was removed during step 1.



CoilSpring Adjusting

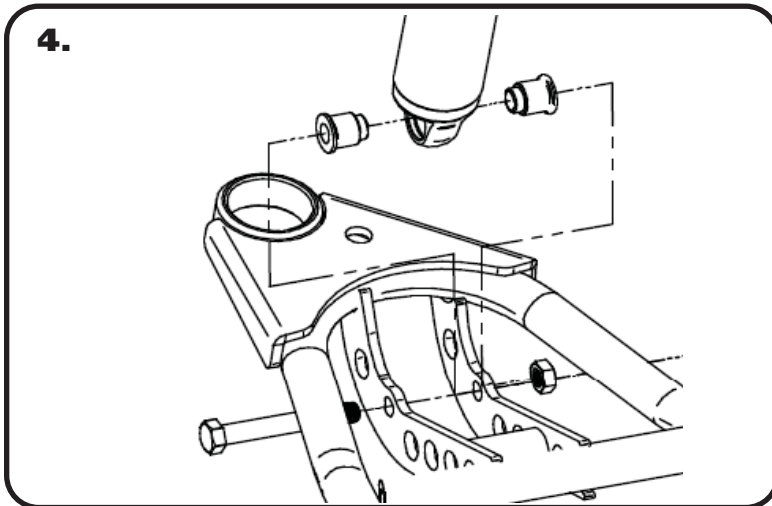

4. Install a spacer on each side of the lower CoilOver. Slide the shock with the spacers installed into the lower control arm. Raise the arm up to line up the holes in the bushing with the 1/2" hole in the control arm straps and hold it in place while you install the 1/2" x 3 1/2" bolt, 1/2" flat washer, and 1/2" Nylok nut. Tighten the upper and lower shock bolts.

Ride Height

We have designed most cars to have a ride height of about 1 1/2" lower than factory. To achieve the best ride quality & handling, the shock absorber needs to be at 40-60% overall travel when the car is at ride height. This will ensure that the shock will not bottom out or top out over even the largest bumps. Measuring the shock can be difficult, especially on some front suspensions. Measuring overall wheel travel is just as effective and can be much easier. Most cars will have 4-6" of overall wheel travel. One easy way to determine where you are at in wheel travel is to take a measurement from the fender lip (center of the wheel) to the ground. Then lift the car by the frame until the wheel is just touching the ground, re-measure. This will indicate how far you are from full extension of the shock. A minimum of 1.5" of extension travel (at the wheel) is needed to ensure that the shock does not top out. If you are more than 3" from full extension of the shock then you are in danger of bottoming out the shock absorber.

Adjusting Spring Height

When assembling the CoilOver, screw the spring retainer tight up to the spring (0 preload). After entire weight of car is on the wheels, jounce the suspension and roll the car forward and backward to alleviate suspension bind.

- If the car is too high w/ 0 preload then a smaller rate spring is required. Although threading the spring retainer down would lower the car, this could allow the spring to fall out of its seat when lifting the car by the frame.
- If the car is too low w/ 0 preload, then preload can then be added by threading the spring retainer up to achieve ride height. On 2.6" - 4" stroke shocks, up to 1.5" of preload is acceptable. On 5-7" stroke shocks, up to 2.5" of preload is acceptable. If more preload is needed to achieve ride height a stiffer spring rate is required. Too much preload may lead to coil bind, causing ride quality to suffer.



Shock Adjustment

Shock Adjustment 101- Single Adjustable

Rebound Adjustment:

How to adjust your new shocks.

The rebound adjustment knob is located on the top of the shock absorber protruding from the eyelet.

You must first begin at the ZERO setting, then set the shock to a medium setting of 12.



-Begin with the shocks adjusted to the ZERO rebound position (full stiff). Do this by rotating the rebound adjuster knob clockwise until it stops.



-Now turn the rebound adjuster knob counter clock wise 12 clicks. This sets the shock at 12. (settings 21-24 are typically too soft for street use).

Take the vehicle for a test drive.



-if you are satisfied with the ride quality, do not do anything, you are set!

-if the ride quality is too soft increase the damping effect by rotating the rebound knob clock wise 3 clicks.

Take the vehicle for another test drive.



-if the vehicle is too soft increase the damping effect by rotating the rebound knob clock wise 3 additional clicks.



-If the vehicle is too stiff rotate the rebound adjustment knob counter clock wise 2 clicks and you are set!

Take the vehicle for another test drive and repeat the above steps until the ride quality is satisfactory.

Note:

One end of the vehicle will likely reach the desired setting before the other end. If this happens stop adjusting the satisfied end and keep adjusting the unsatisfied end until the overall ride quality is satisfactory.

STILL HAVE QUESTIONS?

Tech line hours

Monday - Friday

8AM - 6PM (EST) 812-482-2932