



350 S. St. Charles St. Jasper, In. 47546
Ph. 812.482.2932 Fax 812.634.6632

www.ridetech.com

Part # 12160298
60-64 Galaxie Air Suspension System

Front Components:

1 12162401 Master Series Single Adjustable Front Shockwaves

Rear Components:

1 12167199 Rear AirBar – Bolt-on 4 Link

1 21150801 Rear Master Series Single Adjustable Shockwaves



Part # 12162401 - 60-64 Ford Galaxie Front HQ Shockwave, OEM Control Arms

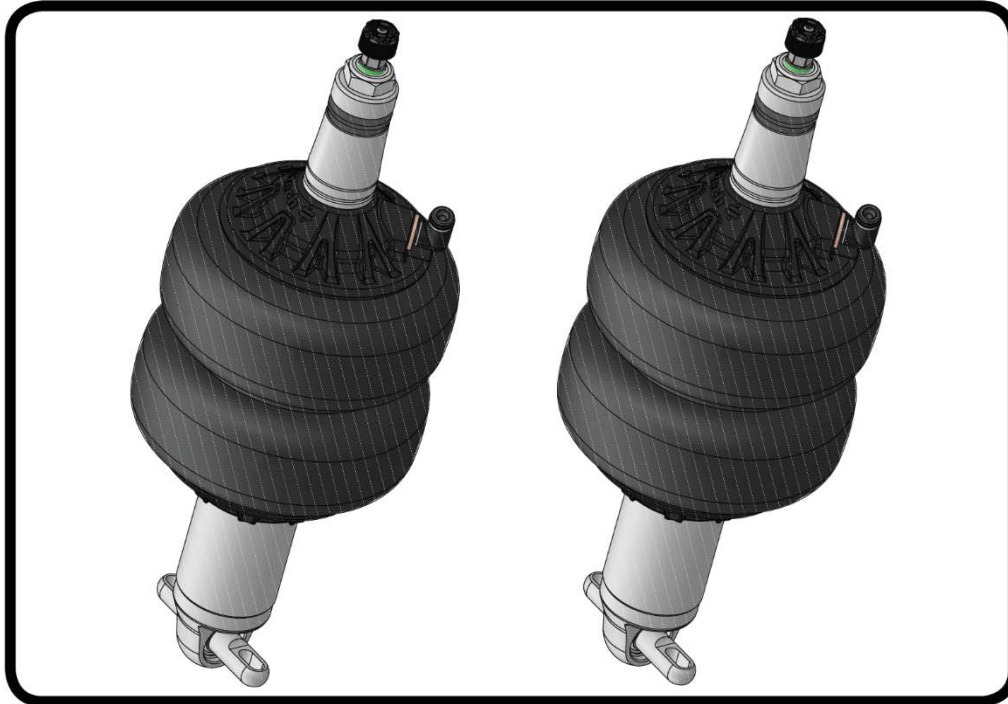

Recommended Tools



1000 Series Bellow, 2.0" Stud/Trunnion 2.9" Shock Installation Instructions

Table of contents

Page 2..... Included components

Page 3-4..... Shockwave Installation

Page 5-6..... Notes and Care of Your Shockwave & Shock Adjustment

ShockWave Dimensions:

Mount to Mount:

Compressed: 9.60"

Ride Height: 11.00"

Extended: 11.90"

THE DELRIN BALL REQUIRES A 3/4" HOLE FOR THE FLANGE TO GO THROUGH. THIS CAN BE DRILLED WITH A UNIBIT.

www.ridetech.com
812-482-2932





Major ComponentsIn the box

THE CONTROL ARM REINFORCEMENT MUST BE INSTALLED BETWEEN THE TRUNNION AND CONTROL ARM. See Image 7.

Item #	Part #	Description	QTY
1	982-10-802	2.9" Stroke HQ Series Shock	2
2	90009986	2" Stud Top (Installed on Shock) - Includes Adjuster Knob & Screw	2
3	24090199	1000 Series 6.5" Double Convoluted AirSpring	2
4	234-00-153	AirSpring Locking Ring (Installed on shock)	2
5	99055000	Locking Ring Set Screw (Installed on shock)	2
6	90002060	Universal Trunnion	4
7	90002312	2" Aluminum Stud Top Base	2
8	90001904	Bottom Delrin Ball	2
9	90001903	Top Delrin Ball	2
10	90001902	Delrin Ball Aluminum Top Cap	2
11	99562003	9/16"-18 Thin Nylok Nut	2
12	210-35-120-0	Adjuster Knob - (90009986 assembly)	2
13	90009969	#4-40 X 1/4" SS, 18-8 Pan Head Torx Cap - (90009986 assembly)	2
14	90001980	Trunnion Locking Rings	4
	90001259	Control Arm Reinforcement Plate (NOT SHOWN)	2
	70012160	2" Stud Top Metering Rod (installed in stud top)	2
	90001994	5/8" ID Bearing (installed in shock and eyelet)	4
	90001995	Bearing Snap Ring (installed in shock and eyelet)	8
	99311002	5/16" X 1 1/4" Hex Bolt	4
	99312003	5/16"-18 Nylok Nut	4
	99313002	5/16" SAE Flat Washer	8

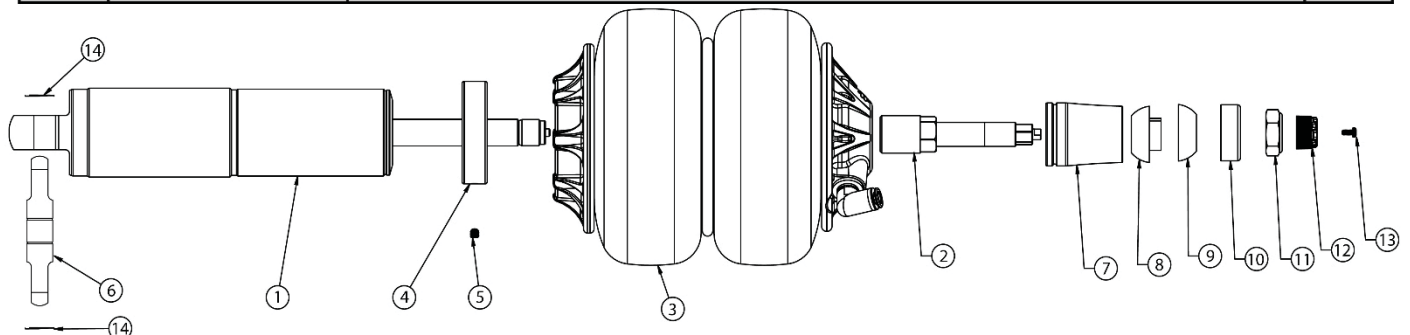

THE DELRIN BALL REQUIRES A 3/4" HOLE FOR THE FLANGE TO GO THROUGH. THIS CAN BE DRILLED WITH A UNIBIT.



ShockWave Installation



1. Raise and support vehicle at a safe, comfortable working height. Let the front suspension hang freely.

2. Remove the coil spring and shock absorber. Refer to factory service manual for proper disassembly procedure.

3. The upper shock hole needs drilled to 3/4". A Unibit works well for drilling the hole.



4. Trim the coil spring location ring flush to prevent the ring from hitting the top of the ShockWave Air Spring. A die grinder with a cutoff wheels works well here.

Allowing the Shockwave to touch the frame at any point through full suspension travel will damage the unit and is not warrantable.

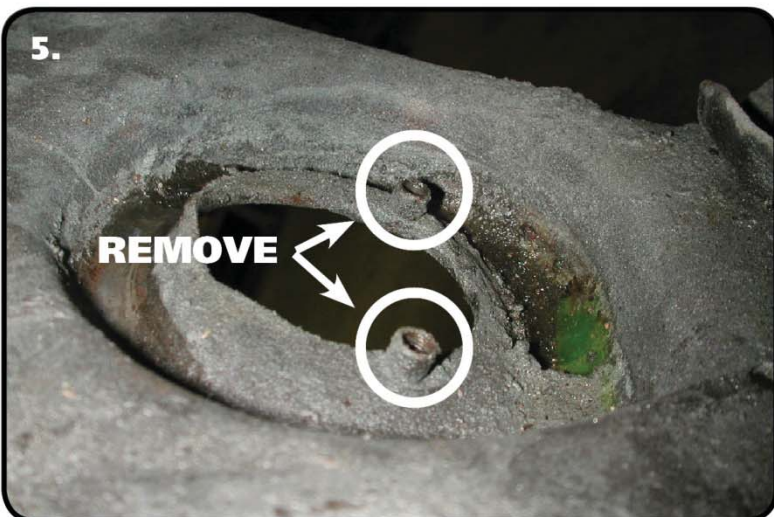

5. The Shockwave trunnion sits on top of the arm as opposed to the factory shock, which bolts to the bottom side of the car. You will have to remove the two OEM nuts that retain the original shock.



ShockWave Installation

6.

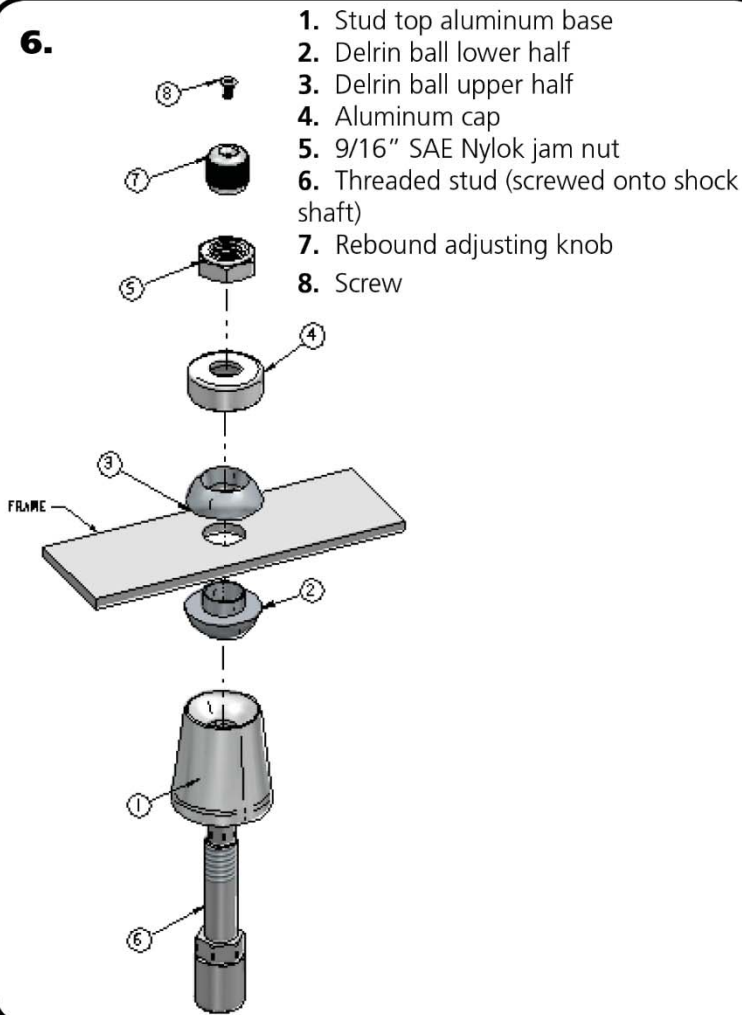

1. Stud top aluminum base
2. Delrin ball lower half
3. Delrin ball upper half
4. Aluminum cap
5. 9/16" SAE Nylok jam nut
6. Threaded stud (screwed onto shock shaft)
7. Rebound adjusting knob
8. Screw

Note: The airline must also be routed at this time. It can be ran through the subframe toward the rear of the vehicle.

6. Apply thread sealant to a 90 degree air fitting and screw it into the top of the Shockwave. The air fitting location can be rotated by twisting the bellow assembly separate of the shock. Place the Shockwave into the coil spring pocket with the stud sticking through the OEM shock hole. See assembly **Diagram 6**. OEM Shock hole **must** be drilled out to $\frac{3}{4}$ "

1. Stud top aluminum base
2. Delrin ball lower half
3. Delrin ball upper half
4. Aluminum cap
5. 9/16" SAE Nylok jam nut
6. Threaded stud (screwed onto shock shaft)
7. Rebound adjusting knob
8. Screw

7.



7. INSTALL THE LOWER CONTROL ARM REINFORCEMENT PLATE. Refer to **Image 7** for positioning of the plate. Raise the lower arm up to the Shockwave and bolt them together using the 5/16" x 1 1/4" Bolts, Washers, & Nylok Nuts supplied with the ShockWaves. Torque to 17 ftlbs.

8. Raise the lower control arm to full compression and double-check to make sure the Shockwave does not rub on anything at anytime. Allowing the Shockwave to rub on anything will cause failure and is not a warrantable situation.

9. Ride height should be around 90 psi but will vary to vehicle weight and driver preference.



Notes and Care of your Shockwaves

NOTES:

WARNING: ATTEMPTING TO REMOVE THE AIR FITTING WILL DAMAGE IT AND VOID THE WARRANTY.

TIGHTENING THE TOP 9/16"-18 NUT: SNUG THE NUT DOWN AGAINST THE TOP CAP. YOU NEED TO BE ABLE TO ARTICULATE THE SHOCK BY HAND.

You can clock the airfitting location on the ShockWave by turning the AirSpring assembly of the shock. Make sure the fitting doesn't contact the frame.

When cutting the airline, use a razor blade. The cut needs to be a clean cut and square for the airline to seal properly.

The Locking ring on the shock is **NOT** adjustable. These rings are set at the factory to optimize the AirSpring stroke with the shock stroke.

The care and feeding of your new ShockWaves

1. Although the ShockWave has an internal bumpstop, **DO NOT DRIVE THE VEHICLE DEFLATED RESTING ON THIS BUMPSTOP. DAMAGE WILL RESULT.** The internal bumpstop will be damaged, the shock bushings will be damaged, and the vehicle shock mounting points may be damaged to the point of failure. This is a non warrantable situation.
2. Do not drive the vehicle overinflated or "topped out". Over a period of time the shock valving will be damaged, possibly to the point of failure. This is a non warrantable situation! If you need to raise your vehicle higher than the ShockWave allows, you will need a longer unit.
3. The ShockWave is designed to give a great ride quality and to raise and lower the vehicle. **IT IS NOT MADE TO HOP OR JUMP!** If you want to hop or jump, hydraulics are a better choice. This abuse will result in bent piston rods, broken shock mounts, and destroyed bushings. This is a non warrantable situation.
4. Do not let the ShockWave bellows rub on anything. Failure will result. This is a non warrantable situation.
5. The ShockWave product has been field tested on numerous vehicles as well as subjected to many different stress tests to ensure that there are no leakage or durability problems. Failures have been nearly nonexistent unless abused as described above. If the Shockwave units are installed properly and are not abused, they will last many, many years. ShockWave units that are returned with broken mounts, bent piston rods, destroyed bumpstops or bushings, or abrasions on the bellows will not be warrantied.



350 S. St. Charles St. Jasper, In. 47546
Ph. 812.482.2932 Fax 812.634.6632
www.ridetech.com

Part # 12167199 60-64 Galaxie Rear AirBar

Components:

2	90000568	Lower axle mount spacer
2	90001444	Lower axle mount
1	90000567	Upper cradle assembly
2	90001624	Lower billet Shockwave mount
2	70002825	Lower Shockwave stud
4	90002067	Aluminum spacer for stud
2	90000144	Axle tabs
2	90000524	Axle tabs
2	90002844	Upper bars – TW 9.875" (C-C length 12.0")
2	90002845	Lower bars – WW 23.25"
2	70013364	RH R-Joint Threaded Housing End (installed in bars)
2	99752004	3/4"-16 jam nut – for R-Joint
14	70013334	R-Joint Spacers
4	70013768	Front Lower R-Joint Spacer
4	99566001	U-Bolts / nuts & washer - Lower axle bracket
2	90001280	Front Lower Bar T-Bushing – 63-34 ONLY
2	70010694	Jig brackets for upper bar installation

R-Joint Components (installed in bar ends)

70013279	Retaining Ring
70012380	Wavo Wave Spring
70013275	R-Joint Center Ball
70013276	R-Joint Composite Center Ball Cage

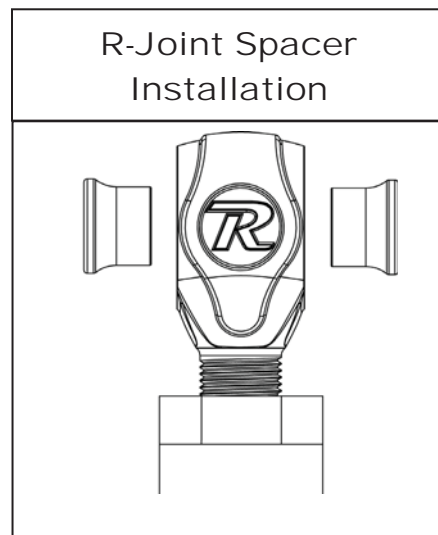

AirBAR

Hardware Kit: (Part # 99010020)

Lower Shock Mount

2	1/2"-13 x 1 1/4" Gr. 5 bolt	Billet mount to axle bracket
2	1/2"-13 x 1 3/4" Gr. 5 bolt	Billet mount to axle bracket
4	1/2"-13 Nylok nut	Billet mount to axle bracket

4 Link Bars

6	5/8"-11 x 2 3/4" Gr.5 bolt	Bar ends
6	5/8"-11 Nylok jam nut	Bar ends

Upper Shock Mounting

2	1/2"-13 x 2 1/4" Gr.5 bolt	Upper Shockwave mount
2	1/2"-13 Nylok jam nut	Upper Shockwave mount

Upper cradle assembly

16	3/8"-16 x 1" Thread forming bolt	Upper cradle assembly
16	3/8" SAE flat washer	Upper cradle assembly

Upper bar installation jig

2	3/8"-16 x 3/4" Gr. 5 bolt	Upper Bar Jig
2	3/8"-16 nut	Upper Bar Jig

63-64 Lower Bar ONLY

2	9/16"-12 x 4 1/2" Bolt	63-64 Front Lower Bar
4	9/16" SAE flat washer	63-64 Front Lower Bar
2	9/16"-12 Nylok Jam Nut	63-64 Front Lower Bar

Shock Stud

2	7/16"-20 Nylok Nuts	Shock Stud
2	7/16" SAE Flat Washer	Shock Stud
2	5/8" SAE Flat Washer	Shock Stud

AirBAR

1. Raise the vehicle to a safe and comfortable working height. Use jack stands to support the vehicle with the suspension hanging freely.
2. Support the axle and remove the leaf springs, shocks, pinion snubber and tail pipes. Refer to the factory service manual for proper disassemble procedures. Keep the factory front leaf spring mounting bolts; they will be reused.

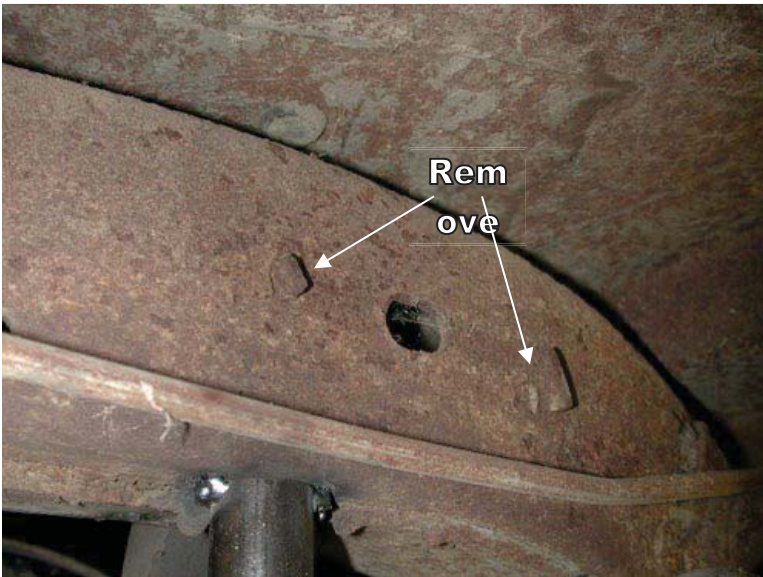

3. On the inside of the frame rail there are two tabs that must be ground smooth.

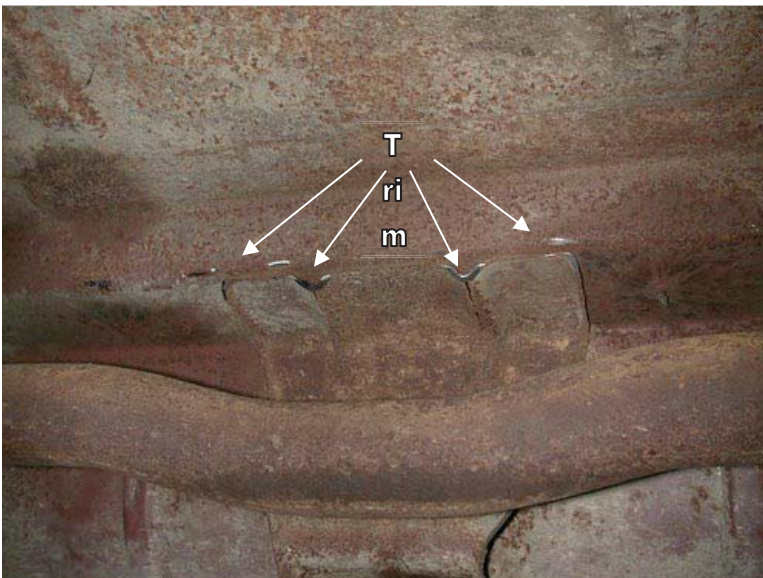

4. You must also trim these grooves in the pan at a 45 deg. angle to allow the upper cradle assemble to slide into place. They are located just in front of the axle above the crossmember.



5. Slide the cradle into place with the upper Shockwave mount toward the rear of the vehicle.

6. You may need to grind the welds smooth on the bottom of the frame to allow the cradle to sit properly.

7. The bolt hole just in front of the Shockwave mount will align with a hole in the frame to position the cradle. Drill the rest of the holes with a 5/16" bit one at a time while threading in a 3/8" x 1" self-tapping bolt. Be careful not to over tighten these bolts.

THERE ARE 2 DIFFERENT FRONT LEAF SPRING BOLT SETUPS DEPENDING ON THE YEAR OF THE CAR. TYPICALLY, THE 60-62 HAVE A 9/16" SHOULDER BOLT, 63-64 HAS A 3/4" SHOULDER BOLT. THE COMPONENTS USED TO MOUNT THE FRONT OF THE LOWER BARS WILL VARY DEPENDING ON THE YEAR OF YOUR CAR.

60-62

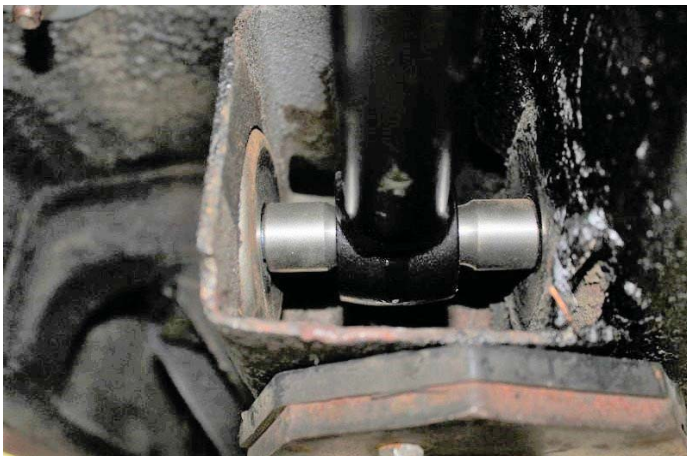

8. The 60-62 years use a 9/16" bolt, it will be reused to attached the lower bars. The Front Lower uses the WIDE(70013768) R-Joint Spacers inserted into each side of the R-Joint.

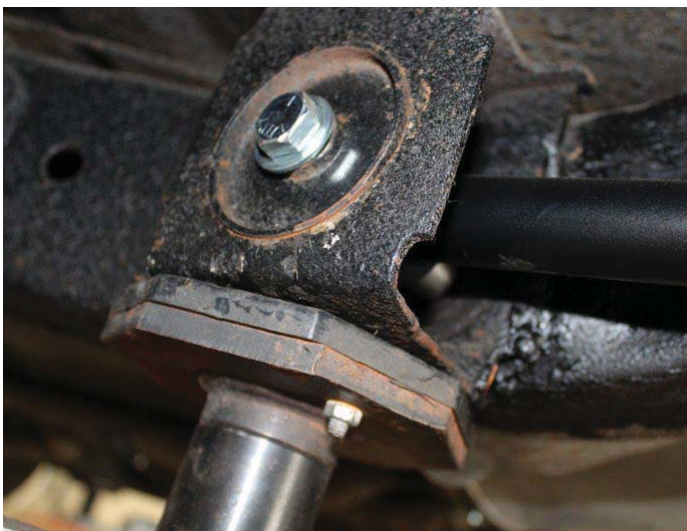

9. With the R-Joint spacers installed, hold the front of the lower bar in the factory leaf spring mount and reinstall the OEM Bolt setup.



10. The 63-64 years use a 3/4" bolt, it will be replaced with the 9/16" x 4 1/2" bolt supplied in the kit. The bolt hole in the frame will need to be drilled out to 9/16". The Front Lower uses the WIDE(70013768) R-Joint Spacers inserted into each side of the R-Joint with the LARGE Aluminum T-bushing in the leaf spring hole.



11. With the R-Joint spacers installed, hold the front of the lower bar in the factory leaf spring mount. Install a 9/16" flat washer on each of the (2) 9/16" x 4 1/2" bolts. Insert the 9/16" x 4 1/2" bolt into the LARGE aluminum t-bushing. Insert the bolt/t-bushing through the R-joint/spacers and through the drilled out hole. The Aluminum T-bushing should nest into the leaf spring hole.



12. Secure the axle mount to the leaf spring pad using the supplied U-bolts. There is an aluminum bushing that will slide over the alignment pin.

13. Bolt the lower Shockwave mount to the axle mount using the 1/2" bolts.

14. Apply anti-seize to the shock stud and screw it into the lower shockwave mount.

15. The Axle end of the bar gets a NARROW(70013334) R-Joint Spacer inserted into each side of the R-Joint. The bar is attached to the Axle Mount in the **MIDDLE HOLE** using the OEM hardware. Swing the lower bar up to the axle mount and insert a 5/8" x 2 3/4" bolt and nylok. This bar should measure 23 1/4" C-C. **Do not tighten any bolts yet.**

Upper Bar Installation Jig

- This jig has been supplied to aid in the installation of the upper 4 link bar. It can be temporarily used to properly align, locate and weld the tabs onto the axle. It will also ensure that the mounting bolts are parallel to the ground.
- Follow the diagram below to set the jig to the same length as the upper bar, use the 3/8" x 3/4" bolt and nuts to set the length.
- Position the axle at ride height. Center the axle left to right between the quarter panels. Set pinion angle.
- Bolt one end of the jig to the cradle using a 5/8" x 2 3/4" bolt.
- Using another 5/8" x 2 3/4" bolt, fasten the axle tabs to the other end. The tabs must be bolted to the **outside** of the jig.
- Swing the bar down letting the tabs rest onto the axle. Trim the brackets as necessary to minimize the gap to be welded.
- Check pinion angle, ride height and axle center. Tack-weld the tabs in place.
- Remove jig and install upper bar **using a spacer on each side of the heim end**.
- Repeat this process for the other side.
- Recheck pinion angle, ride height and axle center. (Sound familiar?)
- After the tabs have been tack welded on both sides, remove the upper bars to avoid melting the rubber bushings. Let the axle drop down for better access to the tabs. Lay 1" welds on the inside and outside of the tabs. Skip around from one side to the other to avoid overheating the tube.
-

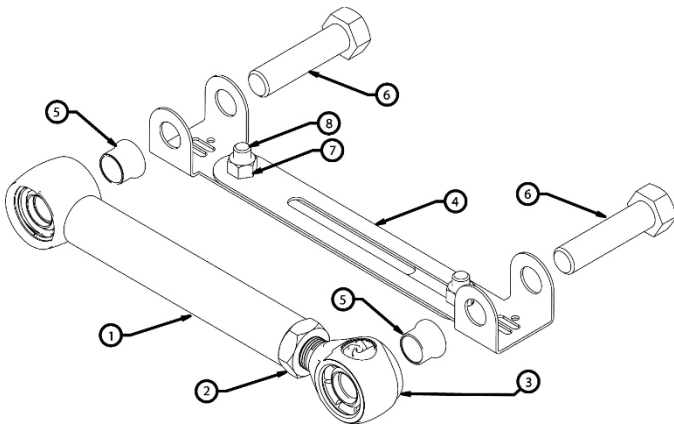

Item #	Description
1.	Upper bar
2.	3/4"-16 jam nut
3.	R-Joint
4.	Alignment jig
5.	R-Joint spacer
6.	5/8"-11 x 2 3/4" bolt
7.	3/8"-16 nut
8.	3/8"-16 x 3/4" bolt



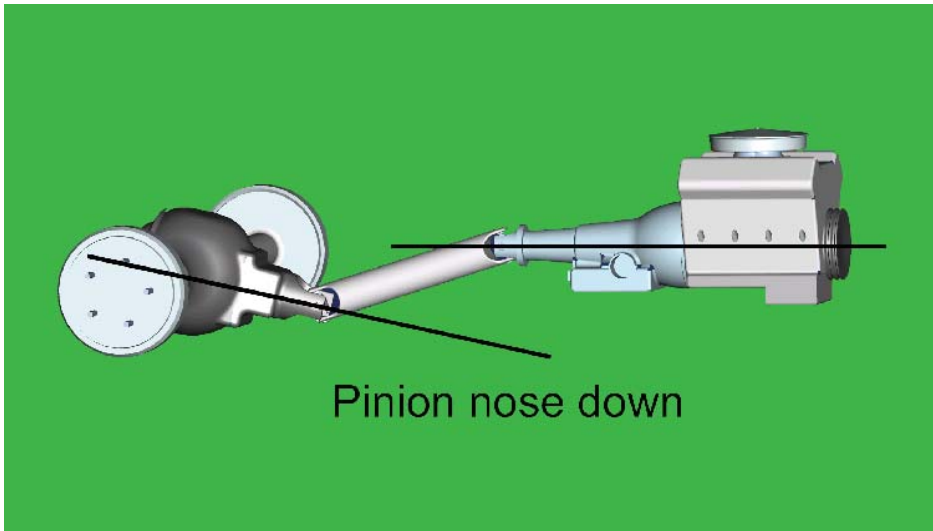

Pinion nose down

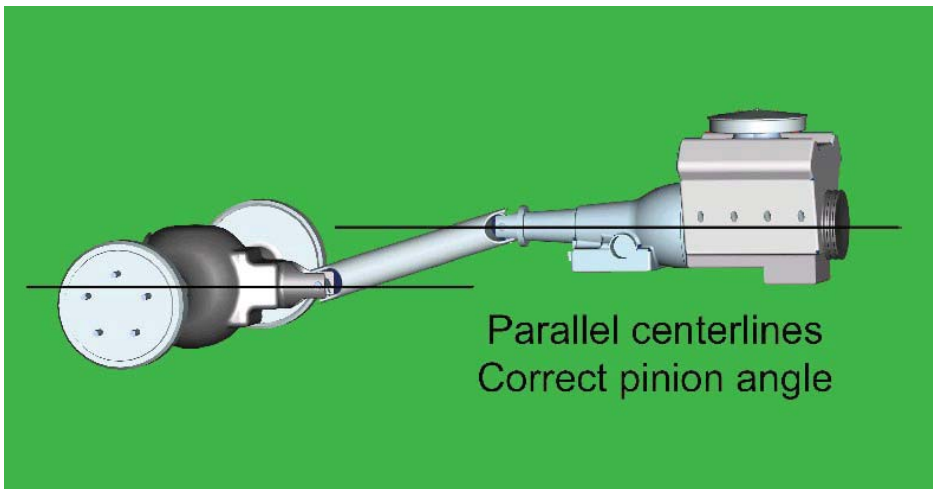

Parallel centerlines
Correct pinion angle

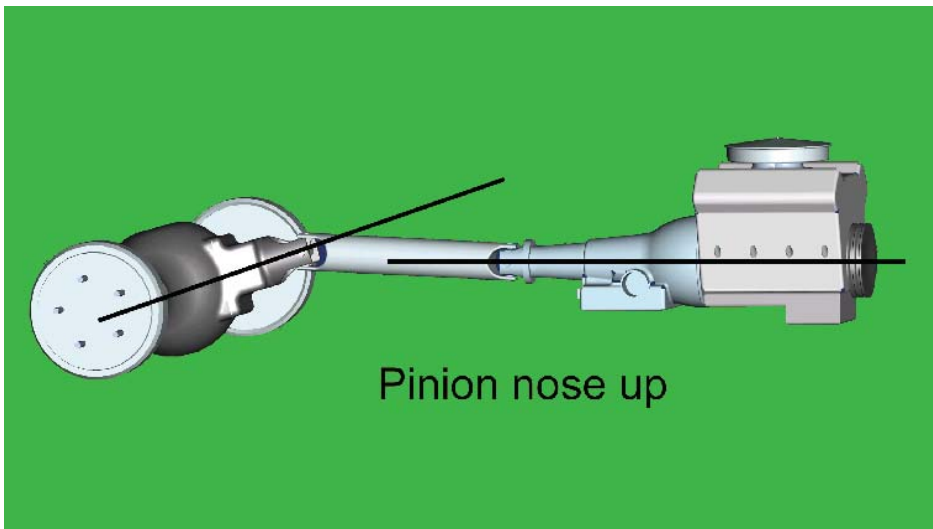

Pinion nose up

How do you set the pinion angle? On a single-piece shaft you want to set it up where a line drawn through the center of the engine crankshaft or output shaft of the transmission and a line drawn through the center of the pinion are parallel to each other but not the same line.

Your transmission angle should be around 3 degrees down in the rear. If it is more or less than 3 degrees, you might want to consider changing it. Too little angle on the transmission reduces the amount of oil getting to the rear bushing. Too much transmission angle will increase the working angles of the u-joints which will increase the wear. With the transmission at 3 degrees down in the rear, you will want to set the pinion 3 degrees up in the front.

A simple way to do this is to place a digital angle finder or dial level on the front face of the lower engine pulley or harmonic balancer. This will give you a reading that is 90 degrees to the crank or output shaft unless you have real problems with your balancer. At the other end, you can place the same level or angle finder against the front face of the pinion yoke that is also at 90 degrees to the centerline. If you rotate the yoke up or down so both angles match, you have perfect alignment.

Road testing will tell you if you have it right. If you accelerate and you get or increase a vibration, then the pinion yoke is too HIGH. Rotate it downward in small increments of a degree or two until the problem goes away. If you get or increase a vibration when decelerating, then the pinion yoke is too LOW. Rotate it upward to correct it.



16. Bolt the axle tabs to the upper bar jig using a 5/8" x 2 3/4" bolt and nyloc as shown in the picture. The upper bar should measure 12" C-C.

17. Bolt the other end into the upper cradle and let the tabs rest on top of the axle. **Do not weld yet.** You must first set pinion angle (which is explained on the next page) and center the axle.

18. Centering the axle is best done by hanging a plum off of the axle and measuring out to the axle flange.



19. This must all be set at **ride height**, which will occur with 14.5" from c-c on the Shockwave mounts. As you can see in the above picture, we have tack welded a 5" long spacer between the axle and frame to maintain ride height, axle center, and pinion angle while welding in the tabs.

You can now tighten all of the 4 link bolts.



20. Apply thread sealant to the air fitting and screw it into the top of the Shockwave.

21. Attach the top of the Shockwave/CoilOver to the cradle with a 1/2" x 2 1/4" bolt and nyloc. Place the washer over the shock stud, and then slide the Shockwave over the stud. Another washer and nyloc will hold in tight.

22. Remove the spacer.

23. Double-check all clearances with parking brake cable, vent tubes, brake lines, etc.

24. Ride height should be around 70psi but will vary to driver preference.



Part # 21150801 - 5.2" Stroke HQ Series Shockwave

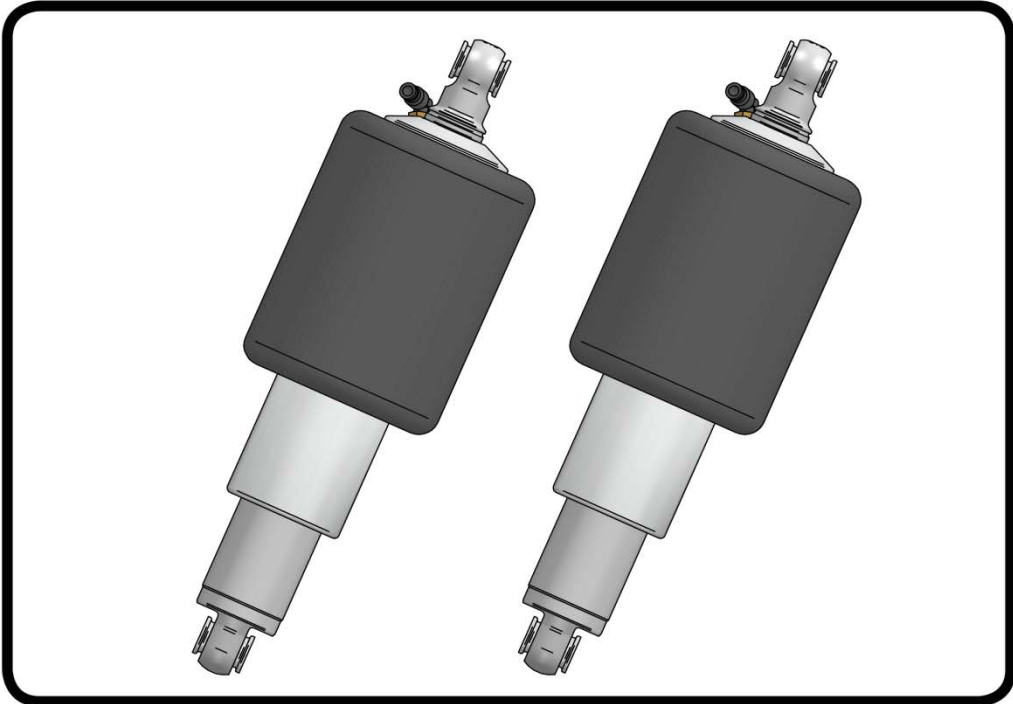

Recommended Tools



8000 Series Bellow, Eye/Eye 5.2" Shock Installation Instructions

Table of contents

Page 2..... Included components

Page 3..... Notes and Care of Your Shockwave

Page 4..... Shock Adjustment

ShockWave Dimensions:

Center of bearing to Center of bearing:	
Compressed:	11.85"
Ride Height:	14.60"
Extended:	16.42"



Major ComponentsIn the box

Item #	Part #	Description	QTY
1	982-10-805	5.2" Stroke HQ Series Shock	2
2	815-05-022	Shock Eyelet	2
3	24090899	8000 Series, 5" Diameter AirSpring	2
4	234-00-153	AirSpring Locking Ring (Installed on Shock)	2
5	90002044	Spacer kit - 1/2" ID and 5/8" ID	4
	90001994	5/8" ID Bearing (installed in shock and eyelet)	4
	90001995	Bearing Snap Ring (installed in shock and eyelet)	8

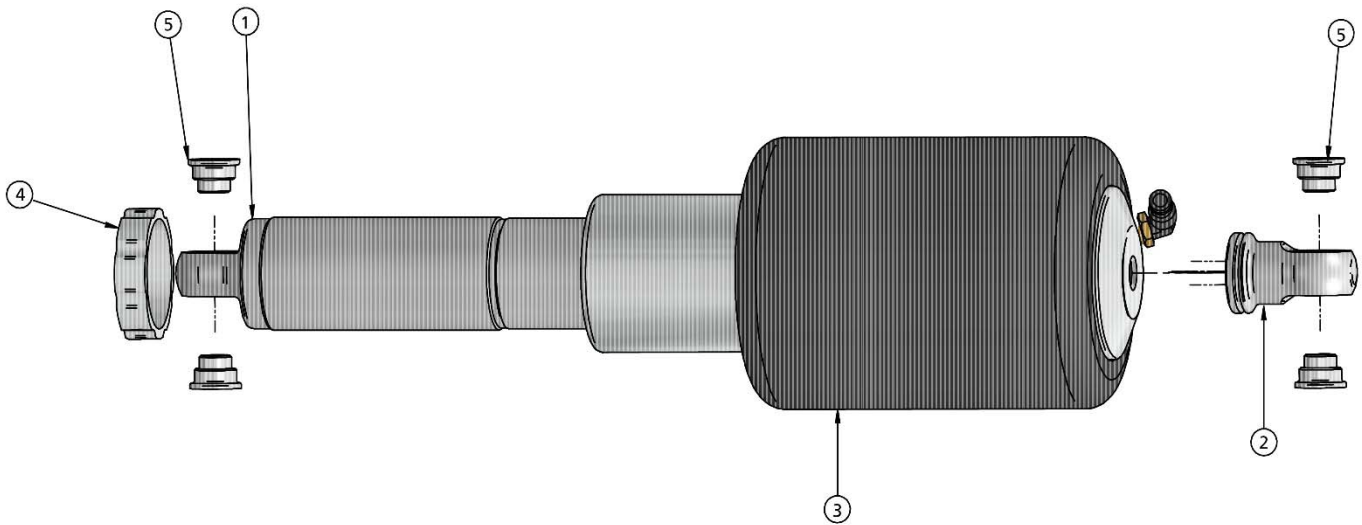

WARNING: ATTEMPTING TO REMOVE THE AIR FITTING WILL DAMAGE IT AND VOID THE WARRANTY.