

Speedway Motors Universal GM 5-Position Tilt Column Installation Instructions

Instructions for installing the following skus:		
91603292	91032971	91603281
91003304	91032972	91603282
91003305	91032973	91603283
91003306	91032974	91603284
91003307	91032975	91603285
91003308	91032976	91603286
91003309	91032977	91603287
91003310	91032978	91603288
91003311	91032979	91603289
91003312	91032980	91603290
91003313	91032981	91603291
	91032982	91603293
		91603294
		91603295
		91603296
		91603297
		91603298

Installation is similar for all columns with the addition of column shifter and linkage and keyed column ignition and neutral safety switch wiring, which are discussed in their appropriate sections at the end of these main instructions. Mockup of the column should be completed to confirm mounting points and proper fitment before the column is painted. Painted columns are not returnable.

Column Mounting

All Speedway Motors columns are 2-inch diameter housings. This requires at least two column mounts that support a 2-inch diameter steering column; one just behind the column's upper bell at the dash and one where the column passes through the firewall. The dash mount must be secured to a steel support bar or a steel dash frame. Do **NOT** mount the column directly to a fiberglass dash frame. If needed, bolt or weld in a cross bar behind the fiberglass dash to support your column's mounting bracket. We offer several column mounts of various drop lengths, as well as firewall mounts (some even vehicle specific) to aid in mounting your column properly. See typical upper and lower column mount brackets in the photo below. Whatever mounting solution you use it must be capable of supporting the column properly, preventing fore and aft movement and rotary movement (clamped tight enough to prevent rotation). Note that all columns must protrude through the firewall a minimum of 1 to 3 inches for proper lower support. Ensure the column is properly positioned with the tilt lever and turn signal lever openings to the left (sitting in the vehicle looking at the column) with the turn signal lever opening level, or at 9 o'clock.

Connecting Your Column's Steering Shaft

The steering column's output shaft on all Speedway Motors columns are of the double D (DD) design. This is a true 1-inch DD shaft compatible with all manner of aftermarket steering shaft joints. Depending upon the angle and length between your column and your steering box or rack-and-pinion input you may need multiple joints, a double joint, additional steering shaft length, and a steering shaft support. Whatever joint you use it must be properly secured to the DD shaft. Typically, these joints use set screws with a retaining lock nut. It is NOT enough to simply tighten the set screw against the DD shaft. You MUST mark and drill a recess with a 1/4-inch drill bit. You are simply spot facing the DD shaft, not drilling completely through it (see Fig 1). This will allow the set screw to seat in the recess for additional safety retention. Ensure the joint is installed so that the DD shaft is flush with the joint end (if it passes the end of the joint body it may impact the U-joint portion of the joint and create binding in the steering) before marking and drilling the recess for each set screw. Finally, apply thread locking compound to the threads of the set screws and lock nuts.



Fig 1.

Your steering joints should not exceed 30 degrees of angle. If your angle exceeds this use a double joint, which can handle up to 70 degrees of angle. If using more than one joint, ensure that the joints are in phase with each other by having the direction of the joint's yoke on the same face or plane. Before final installation and tightening of the column mounts it is critical to have your steering system assembled and centered. If your rack or steering box is not centered, you can rotate it in one direction until it stops and then count the turns in the opposite direction until it stops and divide by two. For example, if your rack-and-pinion is 2-1/2 turns lock-to-lock the center will be 1-1/4 turns from the left or right stop. Center your box or rack and adjust tie-rod ends as necessary (without the rack or box moving from center) to enable a basic front end toe setting of zero to 1/8-inch toe in. This will allow you to safely drive your vehicle to an alignment shop.

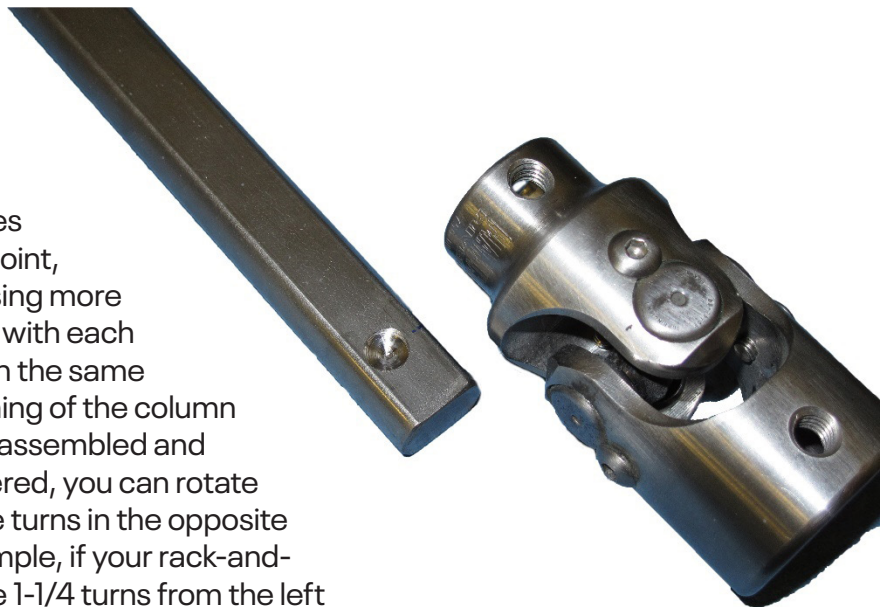

INSTRUCTIONS

© 2024, Speedway Motors, Inc.







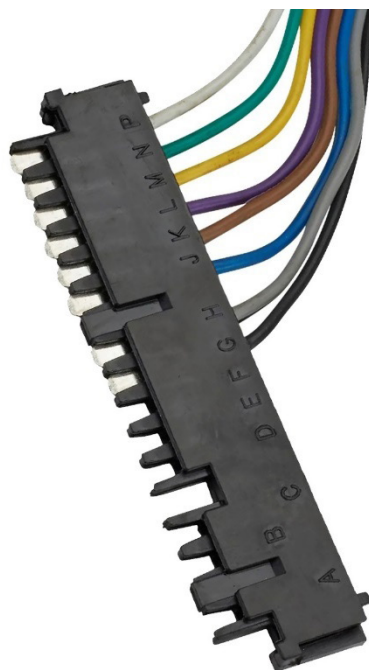

SPEEDWAY
motors®

Wiring Your Turn Signal Switch

Every tilt column from Speedway Motors uses the standard GM 3-7/8-inch long column harness connector for turn signal and horn wiring (see Fig 2). This is compatible with many GM vehicles and aftermarket update chassis harnesses. If your vehicle is wired with the GM 4-1/4-inch mating connector, or you're installing our column into a non-GM vehicle or a pre-'69 GM vehicle we do offer direct fit column wiring connector kits with terminals [PN 910500428] to allow your new tilt column to be a direct plug-in to whatever wiring you may have. Note that there is a separate column ground wire attached at the base of the column that needs to be connected to a solid ground for best operation. The white brake input wire is only used on applications where the brake and turn are the same bulb. If your brake and turn lights are separate bulbs this wire is not used. See Addendum A for converting to non-GM turn signal wiring.

Fig 2



-  **BLACK**
Ground for horn
-  **GRAY**
Left front turn
-  **BLUE**
Right front turn
-  **BROWN**
Hazard flasher power feed
-  **PURPLE**
Turn flasher power feed
-  **YELLOW**
Left rear turn
-  **GREEN**
Right rear turn
-  **WHITE**
Brake switch power feed

Mounting Your Tilt, Turn, and Hazard Warning Controls

Before installing your steering wheel, you will need to mount your turn signal lever. The tilt position lever and hazard warning flasher knob can be installed at any time during column installation, but we are covering all three in this installation section. The turn signal lever is passed through the left side forward most opening in the column head and attached to the turn signal switch with the included mounting screw. The tilt position lever is attached on the left side just behind the turn signal lever by simply threading it into the tilt mechanism. Finally, the hazard warning flasher knob is installed directly opposite the turn signal lever into the turn signal switch assembly by threading the knob into place.

Note: For column shift applications you will need to seat the shifter handle into place on the column's shift mechanism and tap or press the retaining pin into place until the splines are engaged, retaining the shifter handle. There is a small spring that sits behind the column shift lever that seats in a recess in the column housing. You can choose to install this spring first (as shown in the photo at the right) and then the shift lever or compress the spring and install it after the shift lever has been installed.

INSTRUCTIONS

© 2024, Speedway Motors, Inc.

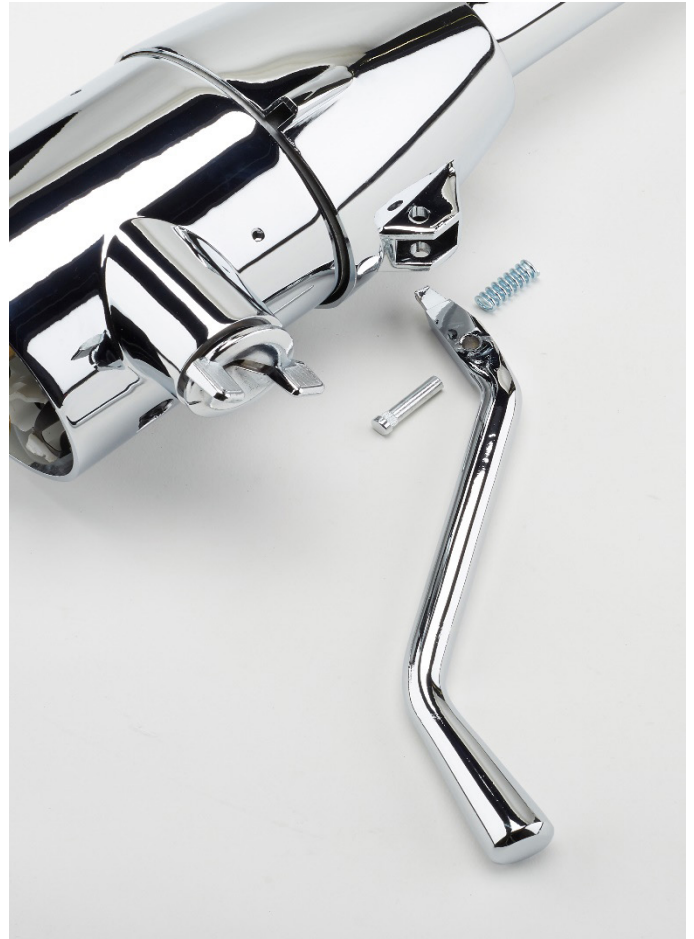

Mounting Your Shift Indicator (column shift applications only)

Place the plastic gear position indicator into the opening in the column shift collar with the red indicator end exposed. Choose the proper shift pattern for your application and install the pattern window into the indicator frame. Secure the indicator frame to the column housing with the two included mounting screws. There is a single wire connection that exits from the column tube along with the turn signal wires that needs to be connected to your existing dash illumination circuit for the gear indicator to illuminate when the dash lights are on.

Installing Your Steering Wheel

Confirm the turn signal cancelling cam with horn wire is seated over the steering column shaft (with large spacer installed first and then the spring) and that the cam's horn connector stud is positioned at the 10:30 clock face position (see Fig 3). Place the included spring over the cancel cam assembly. On columns with integrated ignition switch the thin spacer will seat over the cancelling cam last (see Fig 4). Thread the horn wire through the wheel or adapter opening and seat the wheel or adapter over the canceling cam so that the horn wire and plastic stud pass through the wheel or spacer. This allows the cancelling cam to rotate with the steering wheel. Secure the wheel or spacer with the included retaining nut and tighten to 50 ft-lbs. Connect the horn wire to the terminal on your horn button. If there is a second terminal (often used on plastic buttons or buttons secured by O-rings) this terminal is used as a dedicated ground and you must run a wire from this second terminal to one of the steering wheel or adapter's threaded holes, used for when removing the steering wheel or spacer.

Fig 3



Fig 4

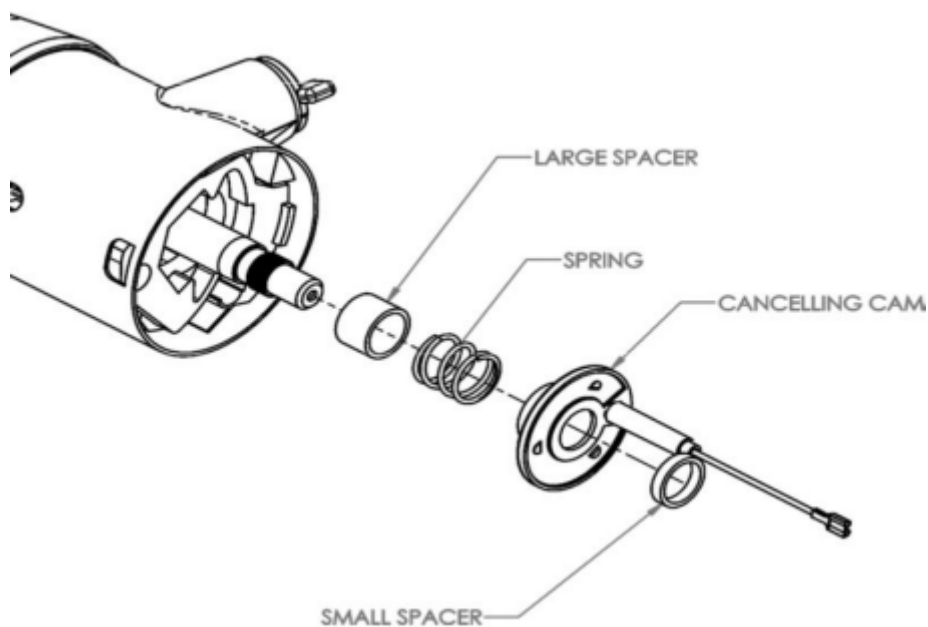

Mounting Your Shift Linkage (column shift applications only)

On column shift applications there is an additional shift lever plate that must be installed at the base of the steering column after it has passed through the firewall. We provide both a flat and an offset shifter plate. The offset plate can be positioned with the shifter lever facing towards the firewall or away from the firewall depending on available clearance. The shift lever plates can be rotated as needed to clear exhaust or other obstructions. Once a suitable position has been verified secure the shift lever plate to the steering column base with the included button head fasteners. The use of our column shift linkage kit, PN 91021903, will make the connection to most transmissions a quick and easy solution.

INSTRUCTIONS

© 2024, Speedway Motors, Inc.

SPEEDWAY
motors®

Connecting Your Ignition Switch Wiring (keyed columns only)

For Speedway Motors tilt columns with integrated GM-style ignition switch we offer the standard two piece white and black ignition switch connectors under PN 9105659C or 910500257. This allows for a much cleaner and more secure connection, though generic spade terminals may be used for wire connections if desired. If using the GM connectors note that the white connector must be seated first, followed by the black connector, which locks them both in place (see Fig. 5). Follow the wiring descriptions in Addendum B to wire your ignition switch properly. The two ground terminals are optional and used only for OE dash warning lamps for low oil pressure, high water temperature, etc. as a bulb "prove out" function. Most applications will not use them. Please note that the A2 terminal uses a wider spade terminal for proper connection (if not using our ignition switch connector kit).



Connecting Your Neutral Safety Switch (keyed columns only)

For Speedway Motors tilt columns with integrated GM-style ignition switch the neutral safety switch (NSS) is mounted at the base of the column past the ignition switch. There are four terminals to connect, two for starter interrupt (so the vehicle will only start in Park or Neutral) and two for backup lights (optional wiring only if your vehicle has backup lights installed). See Addendum C for wire colors.

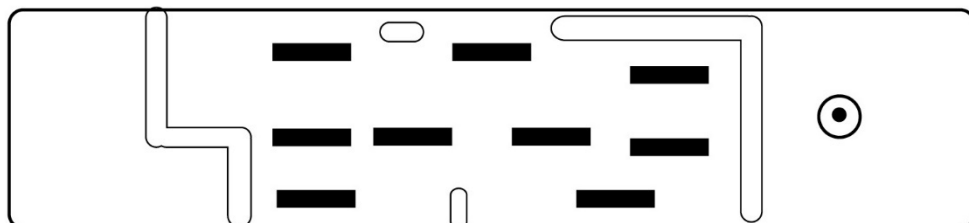
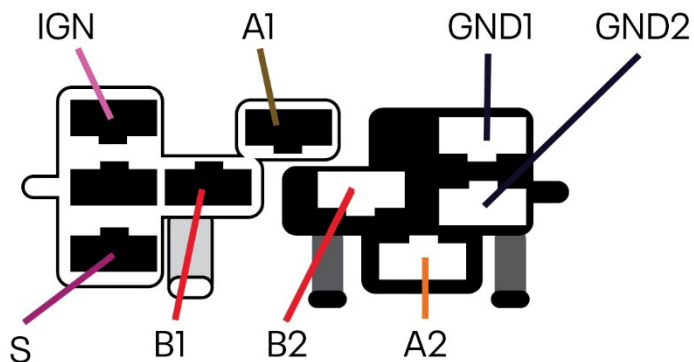
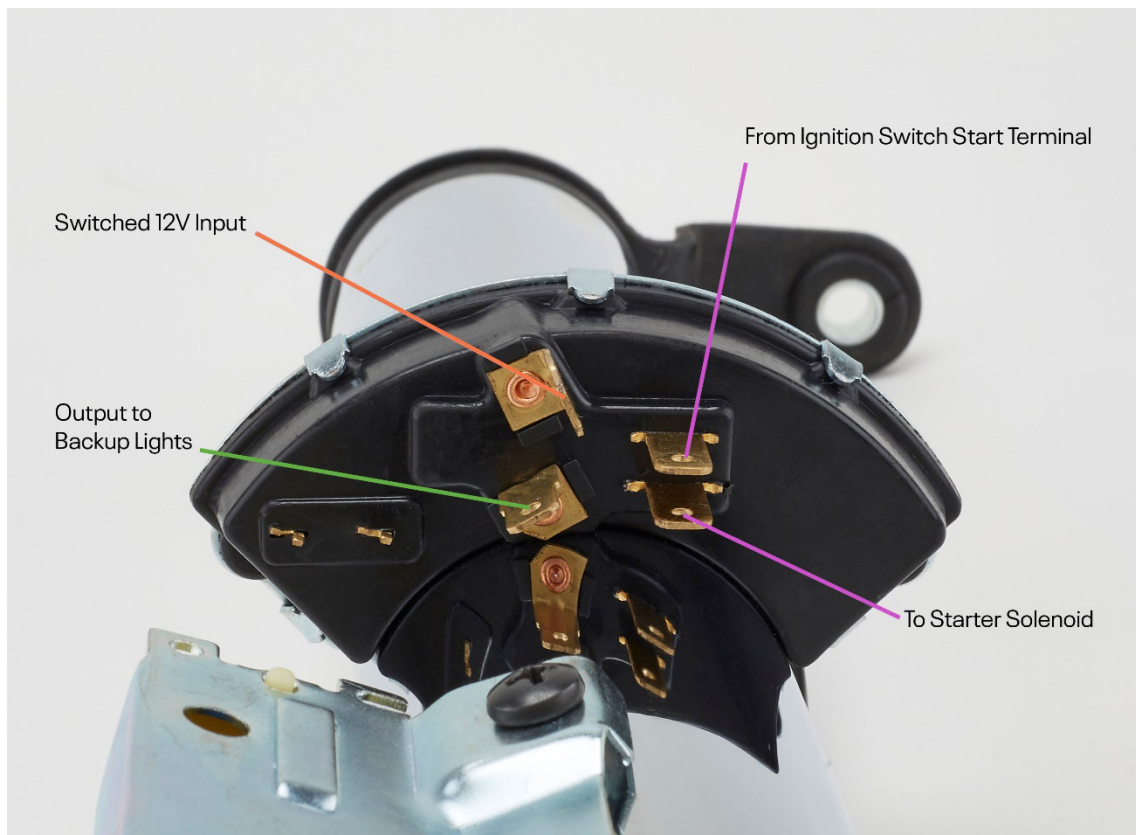

Fig 5

INSTRUCTIONS

© 2024, Speedway Motors, Inc.

SPEEDWAY
motors®



ADDENDUM A: TURN SIGNAL SWITCH CONNECTOR WIRE COLORS

	PORT	GM COLOR	FORD COLOR	1970s CHRYSLER COLOR	1980s CHRYSLER COLOR
Horn	G	Black	Yellow	Black	Black
Left Front Turn	H	Gray	Grn/Wht	Green	Light Green
Right Front Turn	J	Blue	Wht/Blu	Tan	Tan
Hazard Power	K	Brown	Wht/Red	N/A	Pink
Turn Signal Power	L	Purple	Blue	Red	Red
Left Rear Turn	M	Yellow	Grn/Org	Dark Green	Dark Green
Right Rear Turn	N	Green	Org/Blue	Brown	Brown
Brake Light Input	P	White	Green	White	White

INSTRUCTIONS

© 2024, Speedway Motors, Inc.



ADDENDUM B: GM IGNITION SWITCH CONNECTIONS

WHITE CONNECTOR	TERMINAL	GM COLOR	FORD COLOR	1970s CHRYSLER COLOR	1980s CHRYSLER COLOR
Accessory	A1	Brown	Yellow	Black	Black
Battery Power (B+)	B1	Red	Blk/Yel	Green	Light Green
Ignition Coil +	IGN	Pink	Red/Grn	Tan	Tan
Start	S	Purple	Red/Blue	Red	Red
BLACK CONNECTOR	TERMINAL	GM COLOR	FORD COLOR	1970s CHRYSLER COLOR	1980s CHRYSLER COLOR
Accessory	A2	Orange	Black	Blue	Blue
Ignition Switch	B2	Red	Yellow	Red	Red
TERMINAL USE					
A1	Switched power to fuse box (power in On/Run/Acc positions)				
A2	Switched power to fuse box (power in On/Run positions)				
B1	Direct battery feed to ignition switch				
B2	Direct battery feed to ignition switch				
IGN	Switched power to fuse block for coil/EFI (power in On/Run/Start positions)				
S	Switched power to starter solenoid (power only in Start position)				
GND1	Ground output for dash indicator warning light (ground in Start position)				
GND2	Ground output for dash indicator warning light (ground in Start position)				

ADDENDUM C: GM NEUTRAL SAFETY SWITCH CONNECTIONS

BACKUP LIGHTS	GM COLOR	FORD COLOR	1970s CHRYSLER COLOR	1980s CHRYSLER COLOR
12V Switch	Orange	Yellow	Tan	Tan
Output to Backup Lights	Green	Blk/Red	Purple	Purple
STARTER INTERRUPT	GM COLOR	FORD COLOR	1970s CHRYSLER COLOR	1980s CHRYSLER COLOR
From Ignition Switch	Purple	Red/Blue	Red	Red
Output to Starter	Purple	Red/Blue	Yellow	Yellow