

INSTRUCTIONS

© 2025, Speedway Motors, Inc.



910-98205 - TorqLink™ 67-72 Chevy C10 LS Swap Complete Motor Mount Kit

Kit Contents		
Qty	Part #	Description
1	91098204	Bracket Kit
2	91018018	Engine Mounts

This complete kit makes it easy to drop any LS based engine under the hood of your early C10 pickup. The included adapter brackets bolt to the OEM chassis using existing mounting holes and then mate with OEM style LS rubber mounts. No other adapter plates or brackets are needed.

1. Begin the installation by removing the existing engine and mounts from the chassis. Clean up the engine bay as required and prep for the installation of the new adapter bracketry.

2. The slotted holes in the adapter brackets line up with the existing holes in the upper frame flange (2) near the rear of the center cross member and the single lower slotted hole in the center chassis cross member. Loosely bolt the left and right adapter brackets into the chassis at this time.

3. Bolt the included rubber mounts to the LS engine block. Lower the engine into the engine bay and align the mounts with the adapter brackets. The tabs on the engine mounts will sit into the notches of the adapter brackets to assist with alignment.

4. Slide the M12 x 150mm long bolts with washers through the adapter brackets and motor mounts and loosely fasten with supplied lock nuts. Center and square the engine in the chassis, then fully tighten all fasteners.

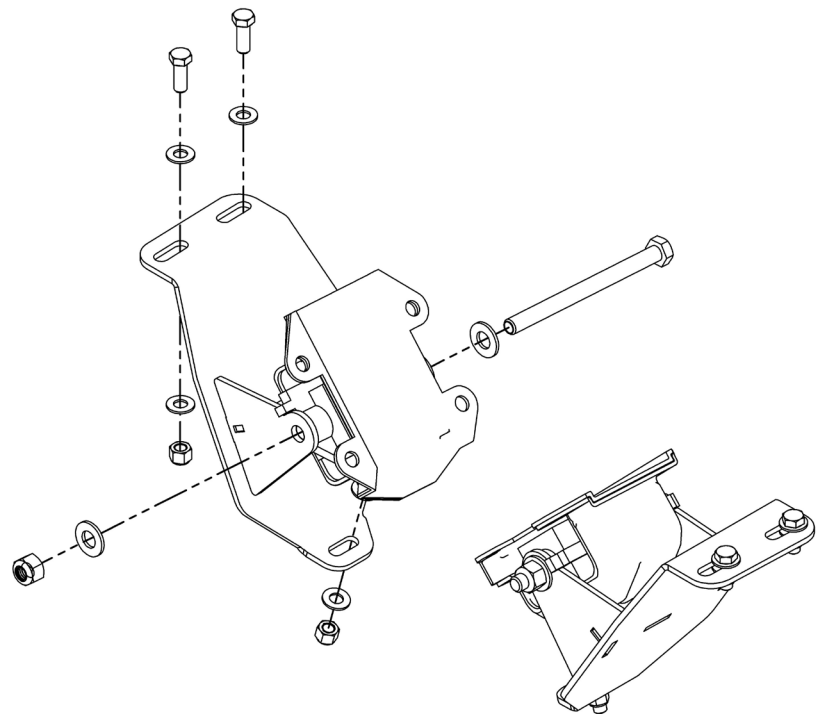

Need Help with This Product?

Talk to one of our Tech Support Agents:

Mon-Fri, 8am - 5pm (CST)

U.S.: 800.979.0122

Canada: 855.313.9180

International: 1.402.323.3200