

INSTRUCTIONS

© 2024, Speedway Motors, Inc.



910-98219 - 1973-80 GM Truck Seat Mount

KIT CONTENTS		
Qty	Description	P/N
1	Seat Base - LH	910-98219.1-L
1	Seat Base - RH	910-98219.1-R
1	Center, Seat Mount	910-98219.2
1	Hardware Kit	910-98213.3

HARDWARE				
Item No.	Qty	P/N	Description	Thread Lock
1	8	HZ5HCSF-.38-2.00	Hex Cap Screw, 3/8-24 X 2, GR-5, Zinc	N/A
2	8	HZ5NLNF-.38	Nylon Lock Nut, 3/8-24, GR-5, Zinc	N/A
3	4	HZ5HCSC-.38-1.00	Hex Cap Screw, 3/8-16 X 1, GR-5, Zinc	N/A
4	4	HZ2SFW-SAE-.38	Flat Washer, 3/8", SAE, Standard, Zinc Plated	N/A
5	8	HZ5HCSF-.31-2.75	Hex Cap Screw, 5/16-24 X 2-3/4, GR-5, Zinc	N/A
6	16	HZ2SFW-SAE-.31	Flat Washer, 5/16", SAE, Standard, Zinc Plated	N/A
7	8	HZ5NLNF-.31	Nylon Lock Nut, 5/16-24, GR-5, Zinc	N/A
HARDWARE FOR "CENTER SUPPORT BRACKET"				
8	1	HZ5HCSF-.25-.75	Hex Cap Screw, 1/4-28 X 3/4, GR-5, Zinc	N/A
9	1	HZ2SFW-SAE-.25	Flat Washer, 1/4", SAE, Standard, Zinc Plated	N/A
10	1	HZ5NLNF-.25	Nylon Lock Nut, 1/4-28, GR-5, Zinc	N/A

1. Begin by removing the four 3/8" bolts that hold the stock bench seat to the cab floor and remove the seat from the vehicle.

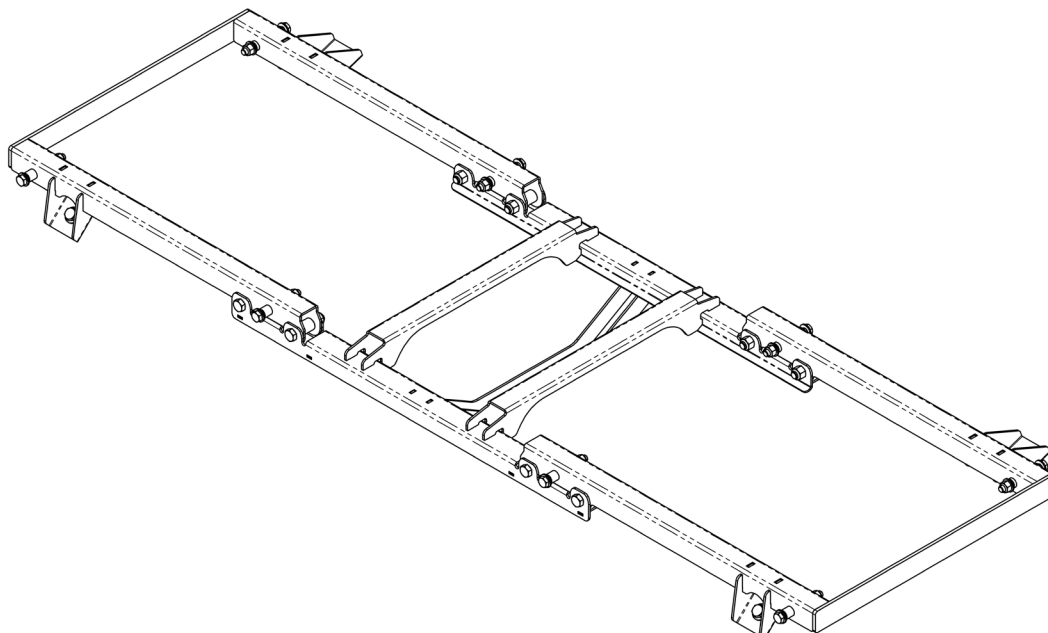

INSTRUCTIONS

© 2024, Speedway Motors, Inc.

SPEEDWAY
motors®

- Loosely assemble the seat frame as shown using the eight $\frac{3}{8}$ " x 2" hex head cap screws and eight $\frac{3}{8}$ " Nylon lock nuts. Leave these bolts loose until the mount is installed in the truck and all bolts are started.

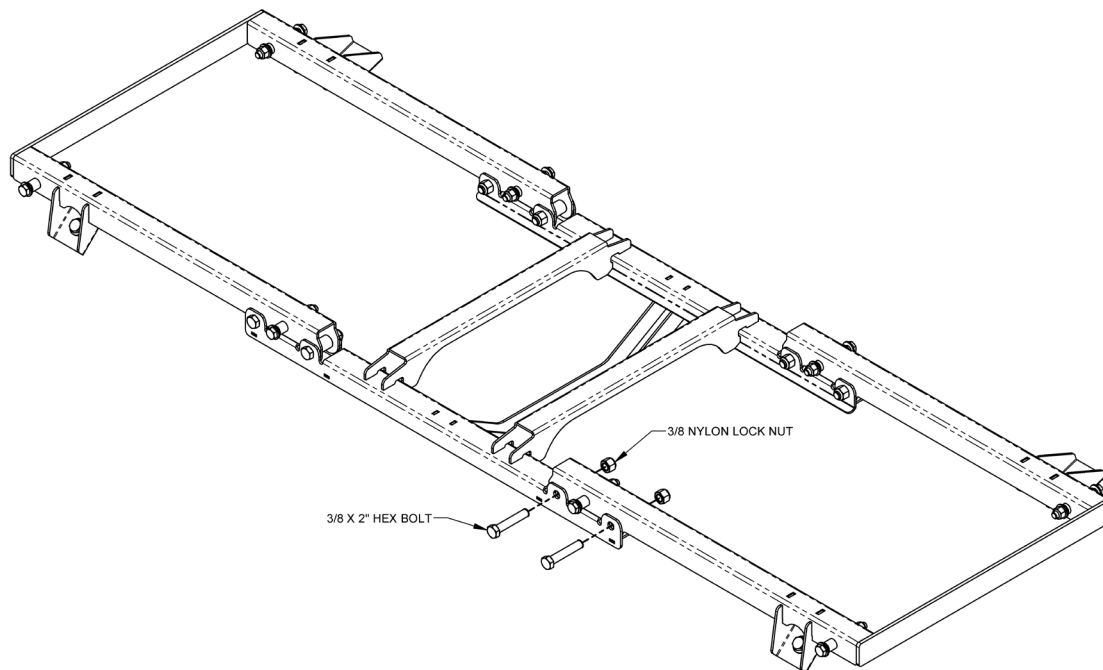

- Install the seat mount into the cab and align the mount holes to the threaded inserts in the floor. Bolt the mount into the cab using the four $\frac{3}{8}$ -16 x 1" hex head cap screws and washers. It helps to start all of the bolts before tightening any of them. Due to manufacturing tolerances, it may be necessary to enlarge some of the holes in the mount plates to align properly with the seat mount holes. Once all are started, tighten the floor mounting bolts and then tighten the seat mount assembly bolts.

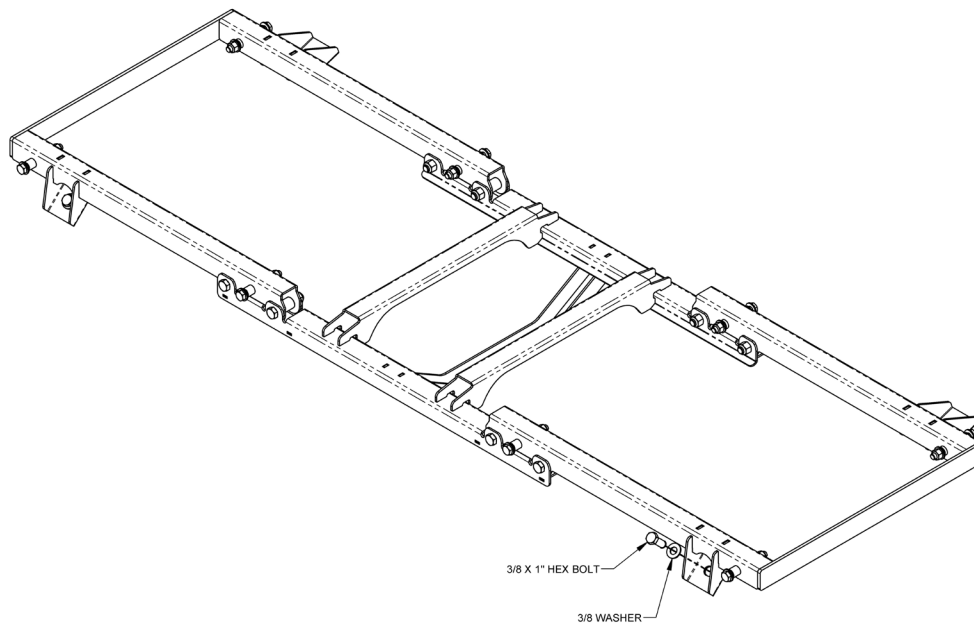

INSTRUCTIONS

© 2024, Speedway Motors, Inc.



4. **Drill the Hole for the Center Support Bracket:** Once you have secured the four outer bolts in place, you will need to drill a hole in the floor for the "Center Support Bracket." Follow these instructions:
 1. **Mark the drilling Location:** Ensure the center support bracket is correctly positioned and mark the spot where the center bolt will go.
 2. **Select the drill bit:** Use a 0.257-inch diameter drill bit to ensure a proper clearance fit for the 1/4-20 bolt provided in the kit. Carefully drill the hole at the marked spot. Ensure the drill is perpendicular to the floor for a straight hole.
 3. **Check the fit:** Insert the 1/4-20 bolt into the hole to confirm it passes through easily without threading. Once installed from the bottom install the flat washer and locknut tightening to approximately 6 to 7 foot-pounds.
5. Assemble seat mount adjuster rails (purchased separately) to the seat bottom. Place seat into cab and position over seat mount so that the slotted holes in the adjuster brackets line up with the sleeves in the seat mount. The front tab of the adjuster with the slots should drop down in front of the sleeve and the rear tab should be in front of the rear sleeve (inside the seat mount frame). The 3 slots in the brackets allow for height and angle adjustment of the installed seat. Install a washer onto the included 5/16-24 x 2-1/2" hex head bolts and slide them through the brackets and sleeves. Install the 5/16-24 Nylon lock nuts and repeat for the other seat. Once everything is installed and clearances have been verified, tighten all bolts.

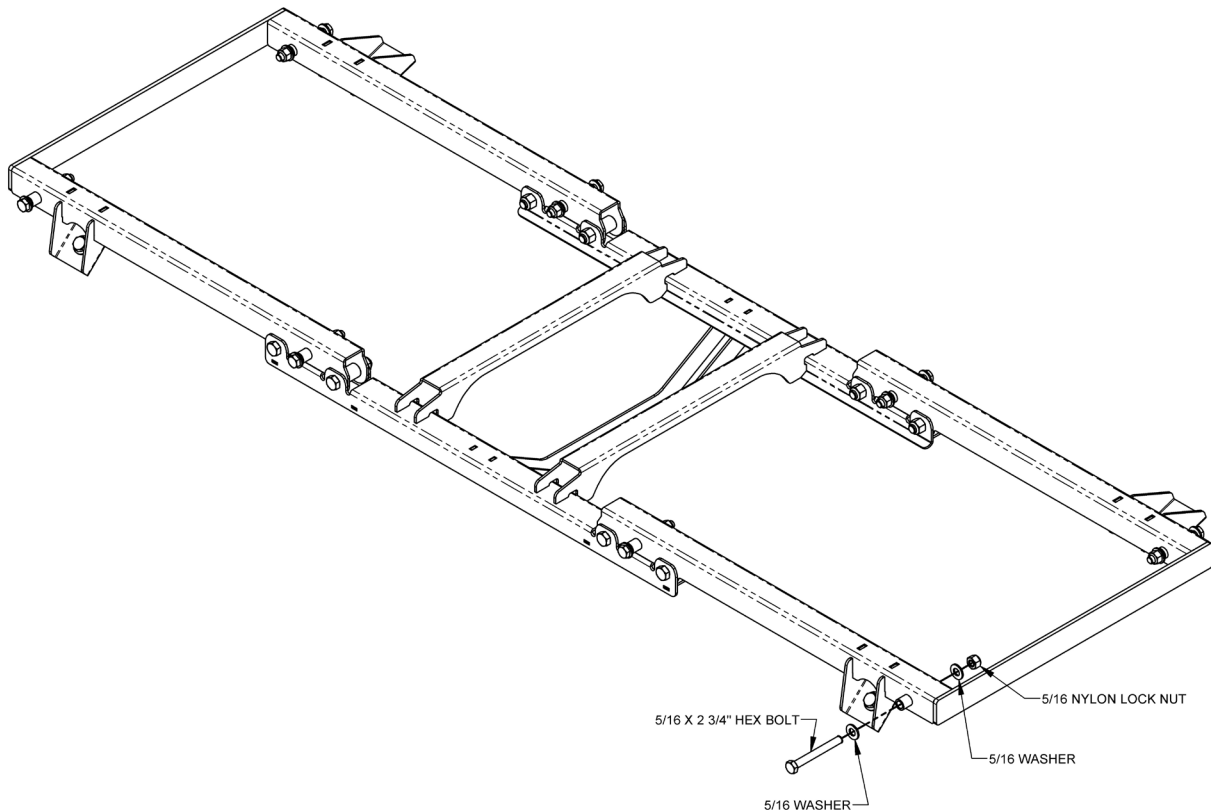

6. Place the center console (purchased separately) onto the seat mount assembly and locate as desired. Mark and drill 4 holes through bottom panel of console and seat mount rails. Fasten center console as required.