

INSTRUCTIONS

© 2024, Speedway Motors, Inc.

SPEEDWAY
motors®

910-98230 - 1973-87 C/K FAB TRANS SUPPORT

Kit Contents			
Qty	Part #	Description	View #
1	91098230.1	Trans Support	1
1	91098230.2	Height Adjuster	2

Hardware			
Qty	Description	Tool Size	Item #
4	Hex Cap Screw, 7/16-20 x 1-1/4" Long, Zinc Plated		H1
4	Nylon Lock Nut, 7/16-20, Zinc Plated		H2
4	Flat Washer, 7/16, Zinc Plated		H3
6	Hex Cap Screw, 3/8-24 x 1" Long, Zinc Plated		H4
6	Nylon Lock Nut, 3/8-24, Zinc Plated		H5
6	Flat Washer, 3/8, Zinc Plated		H6

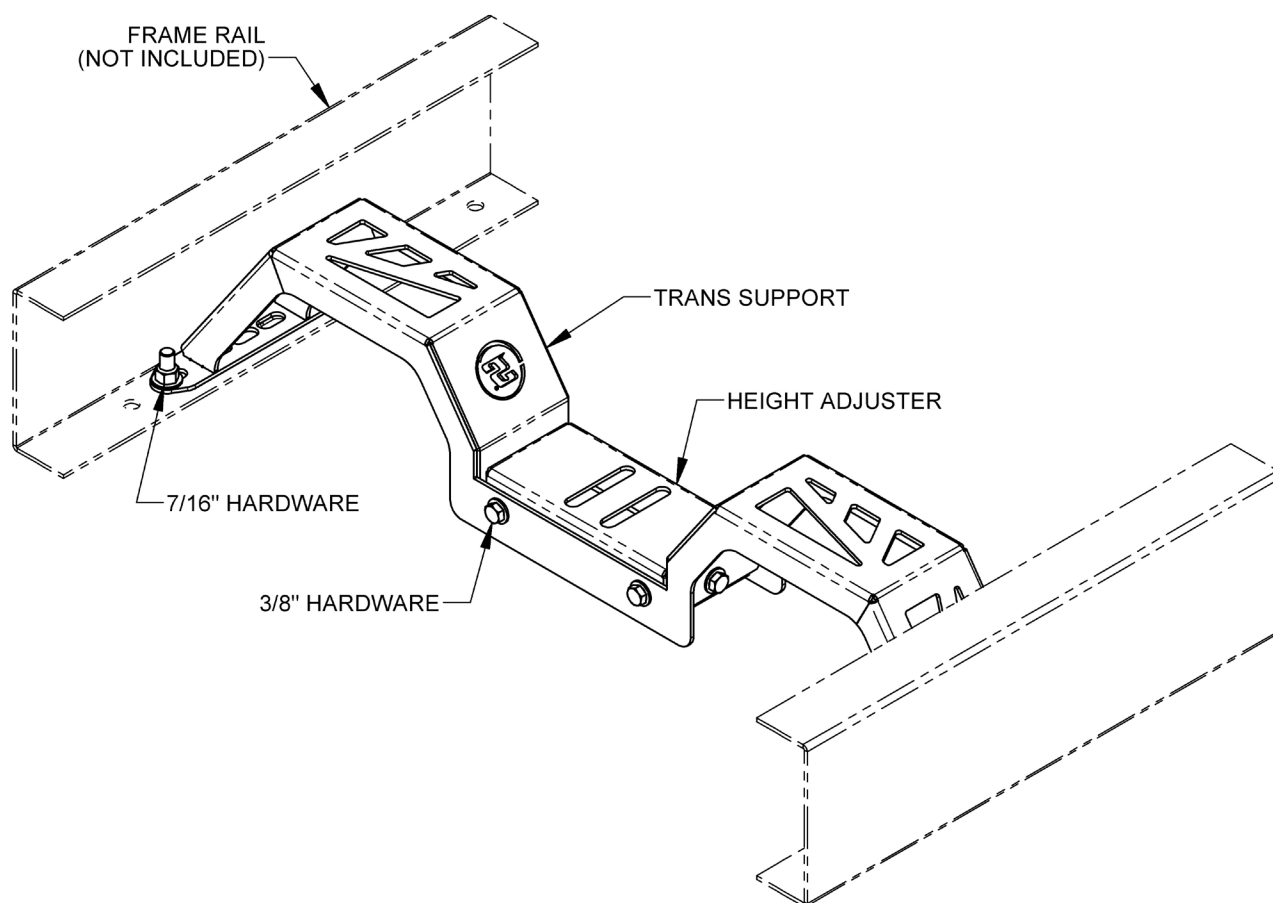

INSTRUCTIONS

© 2024, Speedway Motors, Inc.

SPEEDWAY
motors®

1. After the motor and transmission are installed, support the transmission at the correct angle.
2. Determine the centerline of the transmission mount. Place the transmission support within the frame rails. Bolt the transmission support into existing frame holes that place the centerline of the support within 1" of either side of the transmission mount. Use the 7/16" bolts, washers and lock nuts to fasten to both frame rails.

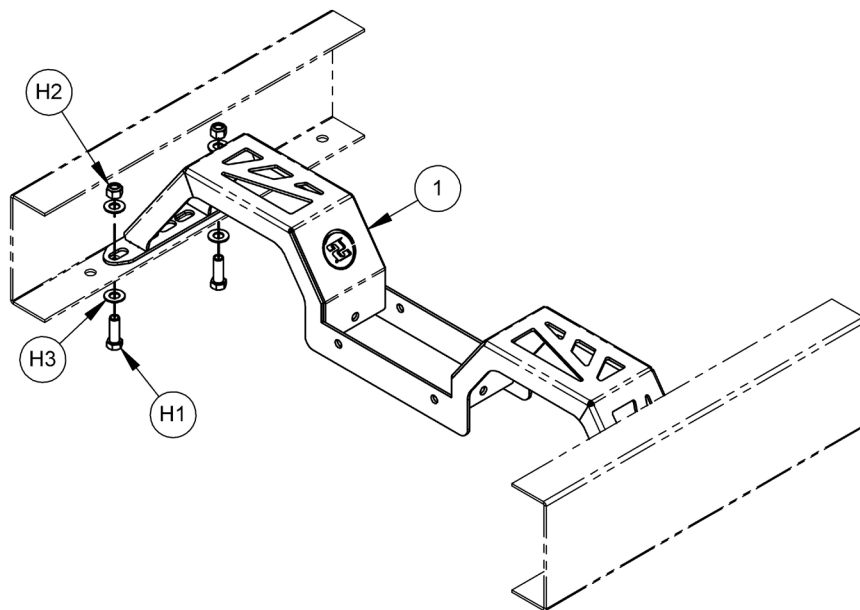

3. With the transmission still at the correct angle install the height adjuster from the bottom of the support until it touches the transmission mount. Determine which hole of the adjuster best aligns with support holes. Fasten the adjuster to the support using the 3/8" bolts, washers and lock nuts as shown below. Repeat in the other five locations.

