

INSTRUCTIONS

© 2025, Speedway Motors, Inc.

SPEEDWAY
motors®

916-17481 - Torque Arm Rear Suspension: 1974-81 Chevy Camaro

KIT CONTENTS		
Qty	Description	P/N
1	Floater Components	350-029.2
1	Sway Bar, Nova Rear	350-402
1	Hardware, Trailing Arm	916-16769.105
1	Hardware, Torque Arm	916-16769.106
1	Hardware, Panhard Arm	916-16769.108
1	Hardware, Shock Mount	916-16769.109
1	Rear End Assembly, 2nd Gen	916-17081.1
1	Subframe Connectors	916-17481.110
1	Torque Arm Parts, 2nd Gen	916-17081.102
1	Trailing Arms and Mounts	916-17081.103
1	Rear Crossmember, 2nd Gen	916-17081.104
1	Hardware, Rear Crossmember, 2nd Gen	916-17081.105
1	Hardware, Subframe Connector	916-17081.106
1	Panhard Bar, 2nd Gen	916-17081.7
1	Hardware, Leaf Mount Bracket	926-10665

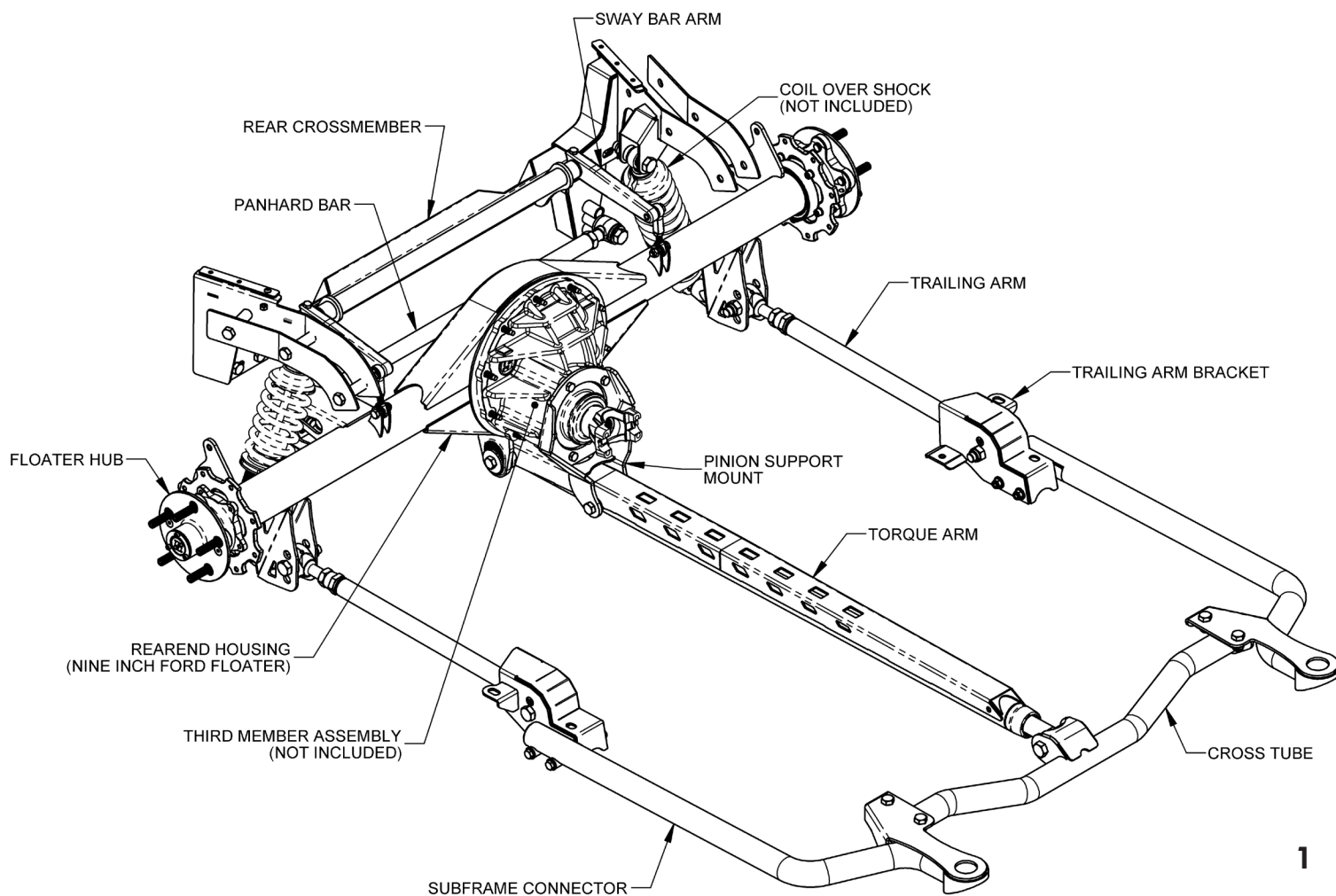

INSTRUCTIONS

© 2021, Speedway Motors, Inc.

SPEEDWAY
motors®

1. Remove Rear Suspension: Raise the car and support it with jack stands or a lift. Remove; the exhaust, drive shaft, rear end, and all rear suspension components including the rubber bump stops. Remove fuel lines, brake lines, and E-brake cables from bottom of car.
2. Positioning Rear Crossmember: Loosely bolt rear crossmember together using the four supplied 1/2"-20 x 3" bolts and lock nuts as shown below. The rear crossmember assembly will sit between the factory frame rails and sit against the floor of the car. The rails should be flush with the outer plates of the assembly. The rear crossmember should be 19-1/2" from the factory rear leaf spring shackle bolts. Clamp the crossmember securely in place.

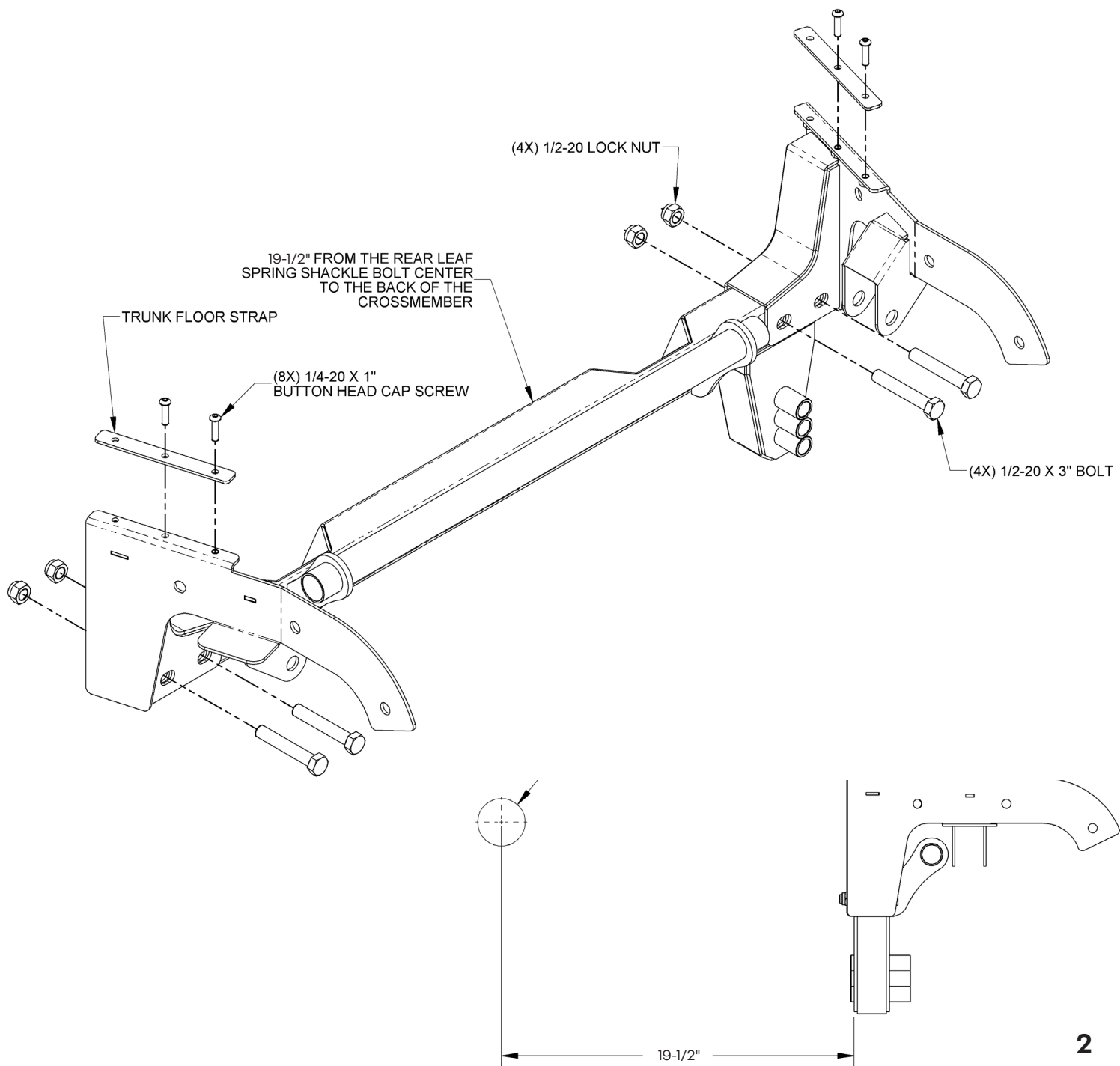

INSTRUCTIONS

© 2021, Speedway Motors, Inc.

SPEEDWAY
motors®

3. Installing Cross Tube and Subframe Connectors: Unbolt the subframe rear bushings. Bolt each subframe connector to the subframe with the lower bushing to the bottom of the connector. Loosely bolt cross tube using the supplied 1/2"-20 x 1" bolts and lock nuts as shown below.

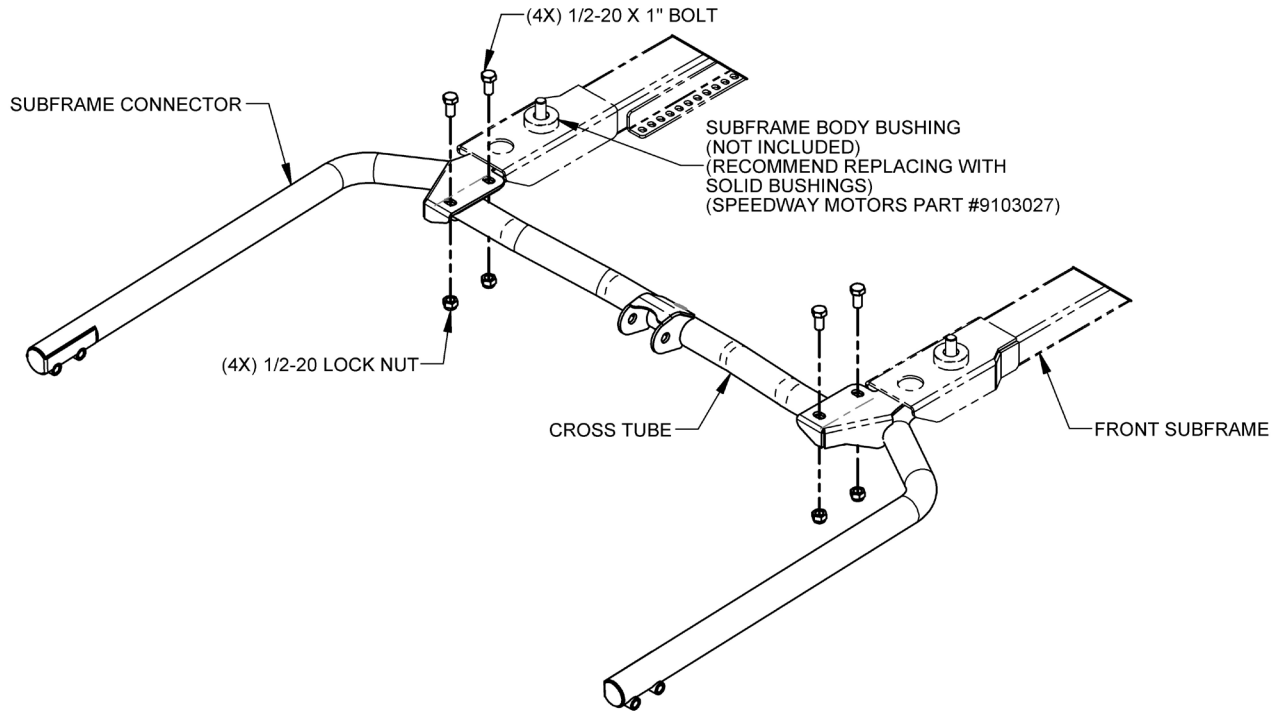

4. Installing Trailing Arm Mounts: Assemble trailing arms leaving the jam nut loose. Center to center dimension should be 23" as a starting point. Bolt the trailing arms into the mount using the supplied 5/8"-18 x 3-3/4" bolt and lock nut as shown below. Note: Install bolt in direction as shown below and fully tighten. Loosely bolt mount to subframe connector using supplied 3/8"-24 x 5" bolts, washers, sleeves and lock nuts. Now loosely bolt the mount to the car using the OE leaf spring bracket hardware. Repeat process for the other side.

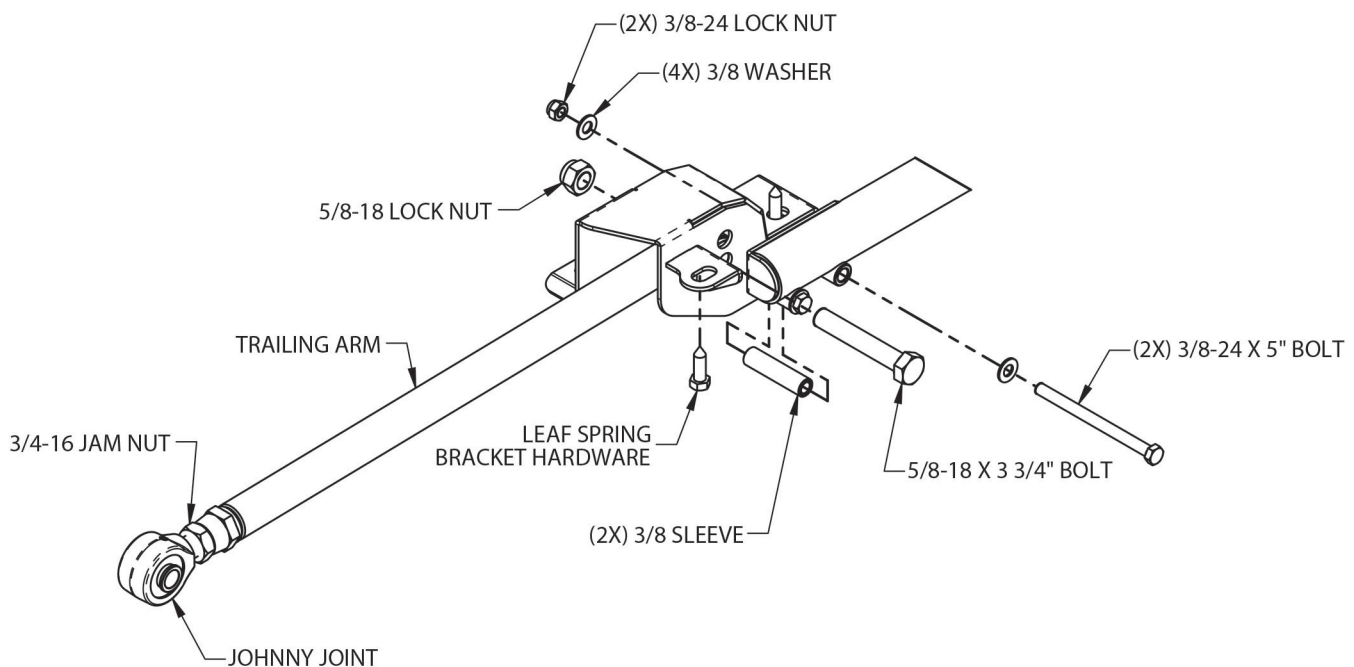

INSTRUCTIONS

© 2021, Speedway Motors, Inc.

SPEEDWAY
motors®

5. **Rearend Housing Install:** Install third member assembly into rearend housing. Remove the 3/8 bolts attaching the pinion support to the third member carrier housing. Attach the pinion support mount onto the pinion support using the supplied 3/8"-16 x 1-1/4" bolts. Apply blue loctite and tighten. Place the rearend housing on stands under the car at the approximate ride height location. Attach the trailing arms using the supplied 5/8"-18 x 3" bolts and lock nuts. Arms should be approximately level at ride height.
6. **Installing the Torque Arm:** Press the supplied spacer into each side of the torque arm. Press the wiper seal into the groove at the end of the torque arm. Slide the torque arm pivot into the end of the torque arm. Attach the torque arm to the housing using the supplied 1/2"-20 x 5-1/2" bolt, serrated washers and lock nut. Attach the torque arm to the pinion support mount using the supplied 1/2"-20 x 4" bolt and lock nut. Attach the torque arm pivot to the cross tube using the supplied 5/8"-18 x 3-3/4" bolt and lock nut.

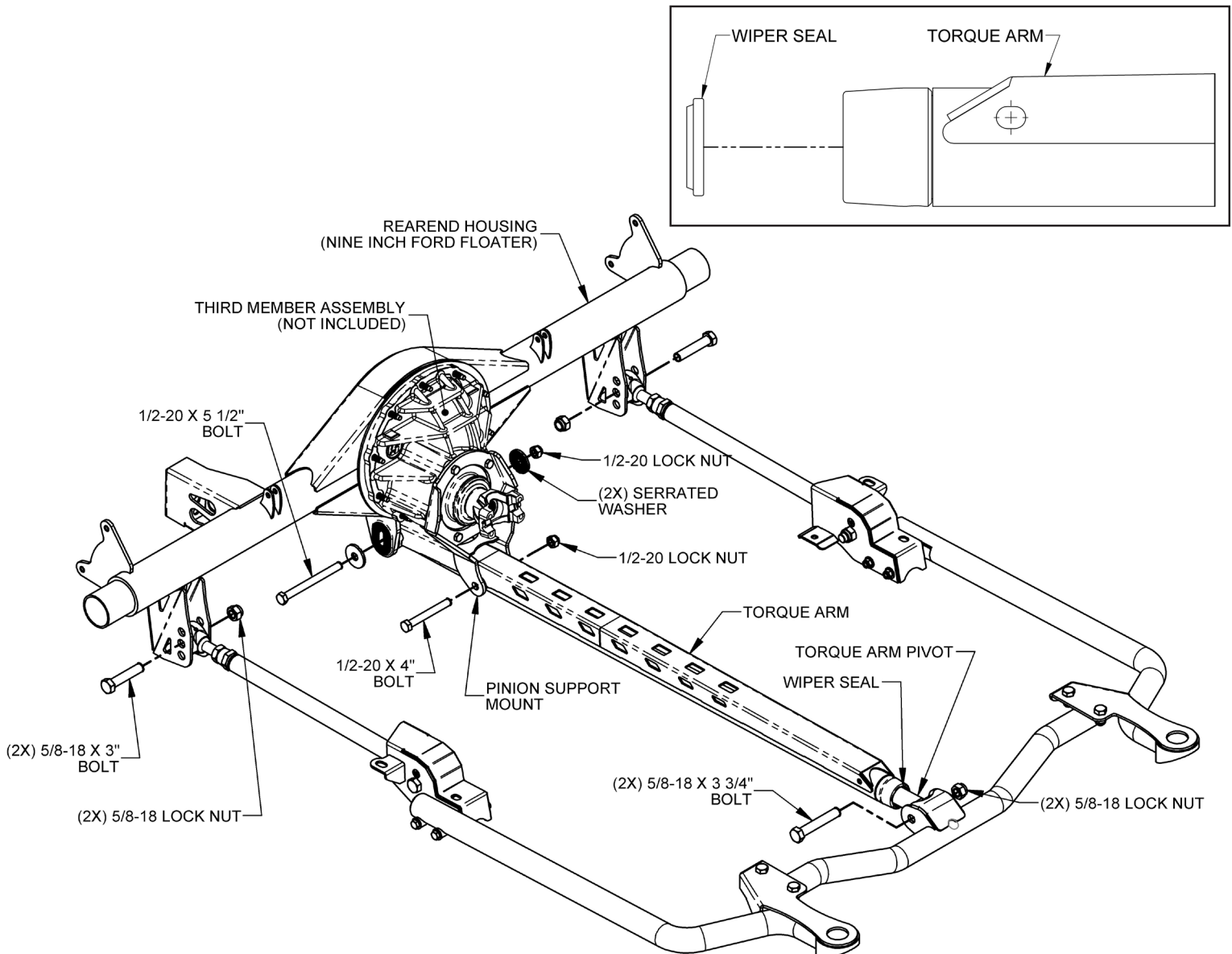

INSTRUCTIONS

© 2021, Speedway Motors, Inc.

SPEEDWAY
motors®

7. Installing the Panhard Bar: Assemble panhard bar leaving the jam nut loose. Center to center dimension should be 30" as a starting point. Attach the panhard bar to the rearend housing using the supplied 5/8"-18 x 3" bolt and lock nut. Attach the panhard bar to the rear cross member using the supplied 5/8"-18 x 6" bolt, washer and lock nut. NOTE: There are three possible locations for each end of the panhard bar. Use the mounting holes that make the panhard bar level with the ground at ride height. This will vary depending on ride height.

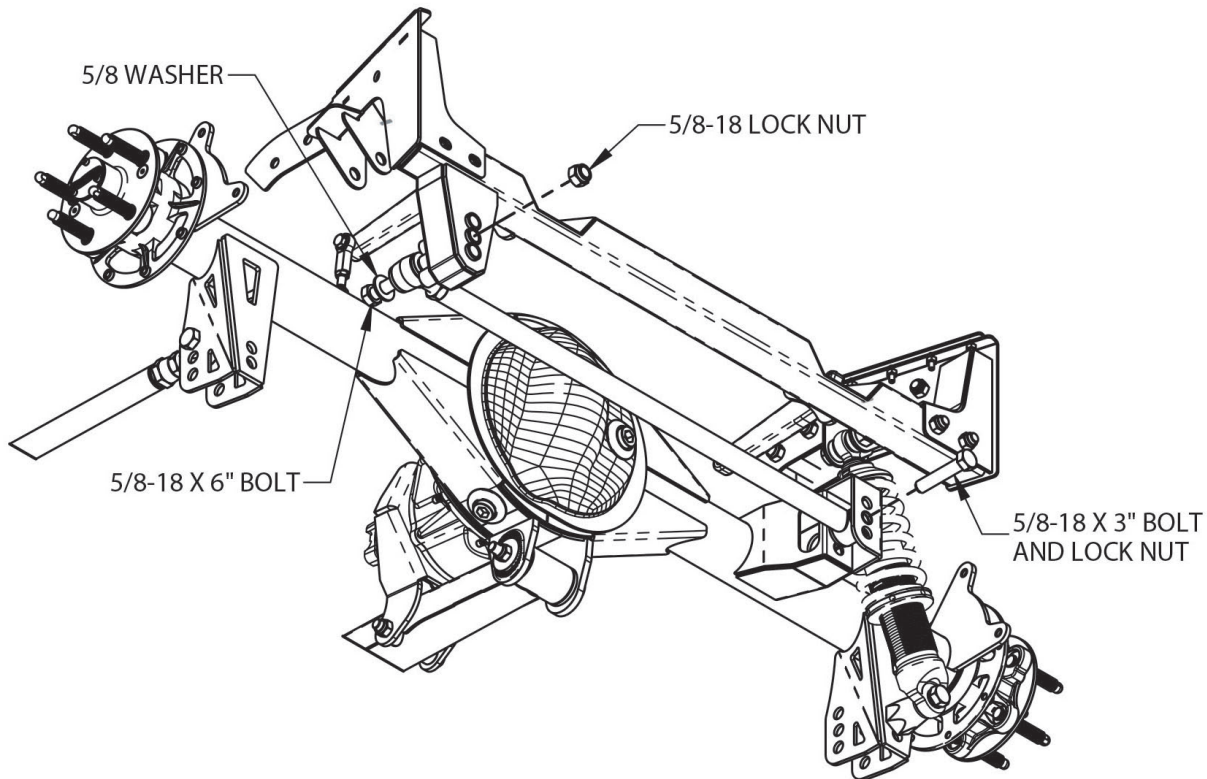

8. Check Alignment and Clearances: At this point, cycle the suspension through its travel and check for any clearance issues.

9. Drilling for Rear Crossmember:

Trunk Floor Strap Holes

- 9.1 Remove components, leaving crossmember securely clamped.
- 9.2 Starting on one side, drill the 2 inner strap holes with 1/4 x 12" long drill bit from the underside of the car.
- 9.3 Install strap with 1/4-20 x 1" cap screws on center holes.
- 9.4 Mark the two outer hole locations to be drilled later.
- 9.5 (Repeat on opposite side)

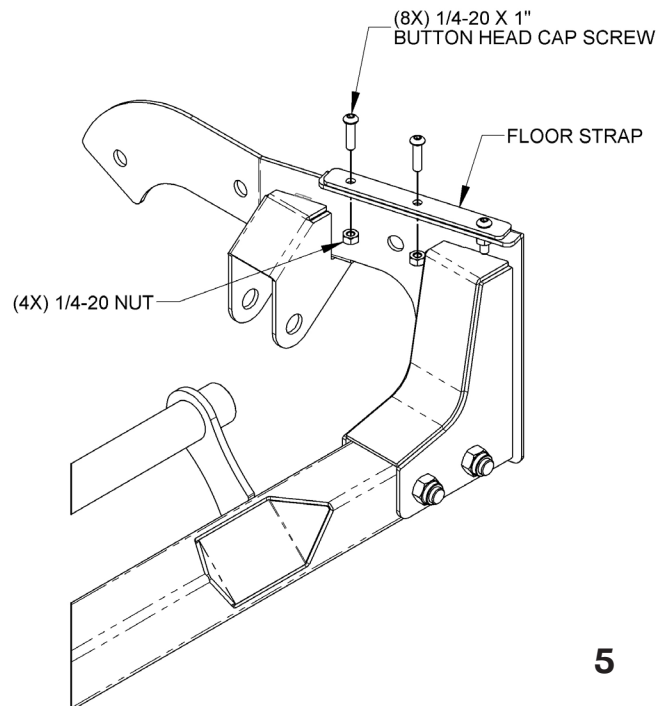

INSTRUCTIONS

© 2021, Speedway Motors, Inc.



Crossmember Frame Holes:

- 9.6 Clamp drill guide into front hole and drill with 1/4" drill bit.
- 9.7 Repeat with second hole.
- 9.8 Enlarge both holes to 1/2".
- 9.9 Secure outer frame plate using the supplied 1/2"-20 x 3" bolt and nuts in front two holes.
- 9.10 Clamp drill guide into the rear hole of the outer plate and clamp to the frame. Drill with 1/4" drill bit.
- 9.11 Enlarge the hole to 1/2".
- 9.12 (Repeat on opposite side)
- 9.13 Unbolt outer frame plate and lower crossmember.
- 9.14 Enlarge only the outer six holes of the frame rail to 3/4".
- 9.15 Insert the 1/2" sleeve, trim to fit.
- 9.16 Drill the four remaining trunk floor strap holes.
- 9.17 Install crossmember with 1/4"-20 x 1" cap screws, floor straps, and nuts.
- 9.18 Install 1/2"-20 bolts, washers, sleeves, outer frame plates and lock nuts. 3" long bolts will be used in the hole towards the rear of the car. 3-1/2" long bolts will be used in the other two holes.
- 9.19 Tighten.

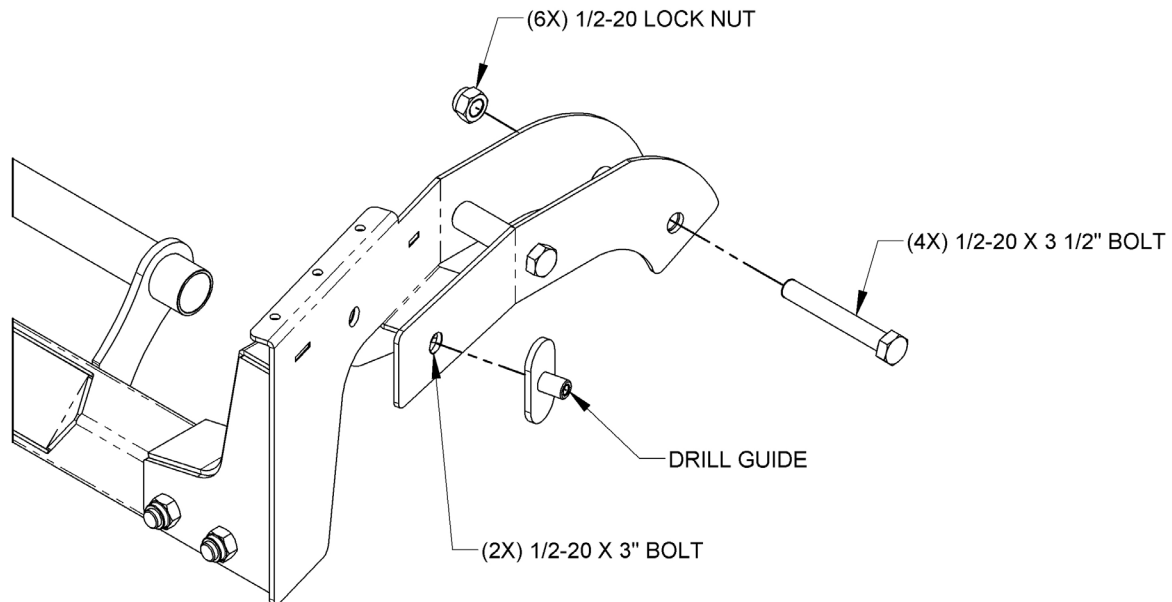

10. Re-Assemble: Reinstall the panhard bar, rear end, and torque arm to the car. Tighten the subframe bushing bolts and cross tube bolts. Jack the rearend to approximate ride height. Square the rearend by adjusting the length of the trailing arms. Once the rearend is squared, tighten bolts for the trailing arms and trailing arm mounts. Adjust panhard bar length to center the rearend. Tighten panhard bar hardware after centered. Tighten the torque arm pivot hardware. Adjust the pinion angle by lowering or raising the rear torque arm bolt within the slot. Once you have reached your desired pinion angle, tighten the remaining torque arm hardware.

INSTRUCTIONS

© 2021, Speedway Motors, Inc.

SPEEDWAY
motors®

11. Install Sway Bar: Press the sway bar bushings into the sway bar housing on the crossmember by lightly tapping them into place with a rubber mallet (be sure the bushings are going in straight). With the bushings in place, slide the sway bar into the housing. Slide one of the torsion arms onto the splined portion of the sway bar so it sits flush with the end of the bar. Install the 5/16-24 x 2" bolt and lock nut onto the arm and tighten. Install one of the male rod ends onto the outside of the arm using a 3/8-16 x 1-1/4" bolt. Now thread the jam nut and female rod end onto the male rod end leaving roughly 1/4" of threads showing. Attach the female rod end to the rear end housing using 3/8-24 x 1-1/4" bolt and lock nut.

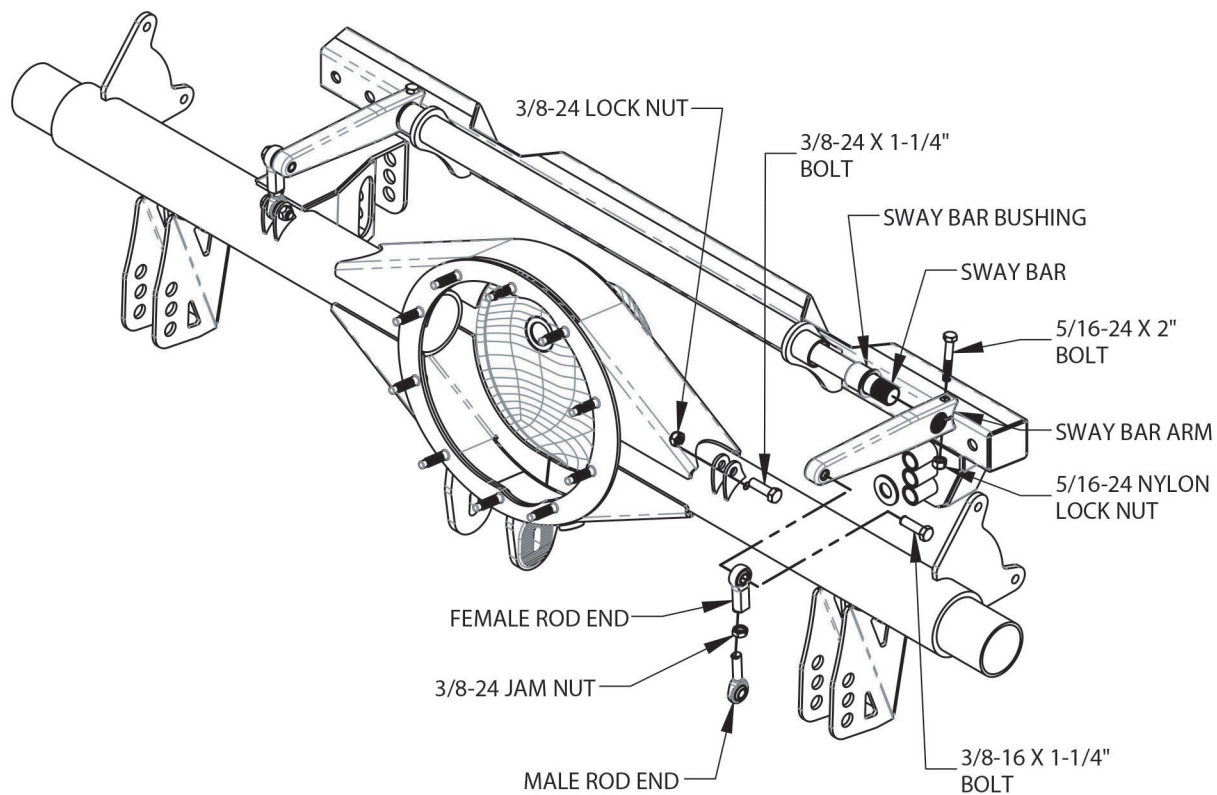

Assemble the opposite side in the same manner. **Note:** Once the vehicle is fully assembled and sitting at ride height on level ground, it is a good idea to disconnect one side of the sway bar links and adjust the length of the rod ends until there is no pre-load and the holes line up perfectly.

INSTRUCTIONS

© 2021, Speedway Motors, Inc.

SPEEDWAY
motors®

12. Now is a good time to fully assemble the rear end by installing hubs, axles, and brakes.

Note: This can also be done after installing the housing into the car.

Assemble the hub as shown below. Be sure to pack the wheel bearings with high quality grease. Do not over torque the axle nut! The hub should spin freely with zero endplay. To achieve this, assemble the hub as shown. Tighten the axle nut and spin the hub a dozen or so rotations. Now back the axle nut off 2 full turns. Then tighten the axle nut until it just starts to get snug. At this point the hub should spin freely with little to no resistance, and there should be no endplay in the bearing. Bend the tab on the lock ring into the groove on the axle nut. This will prevent the axle nut from loosening.

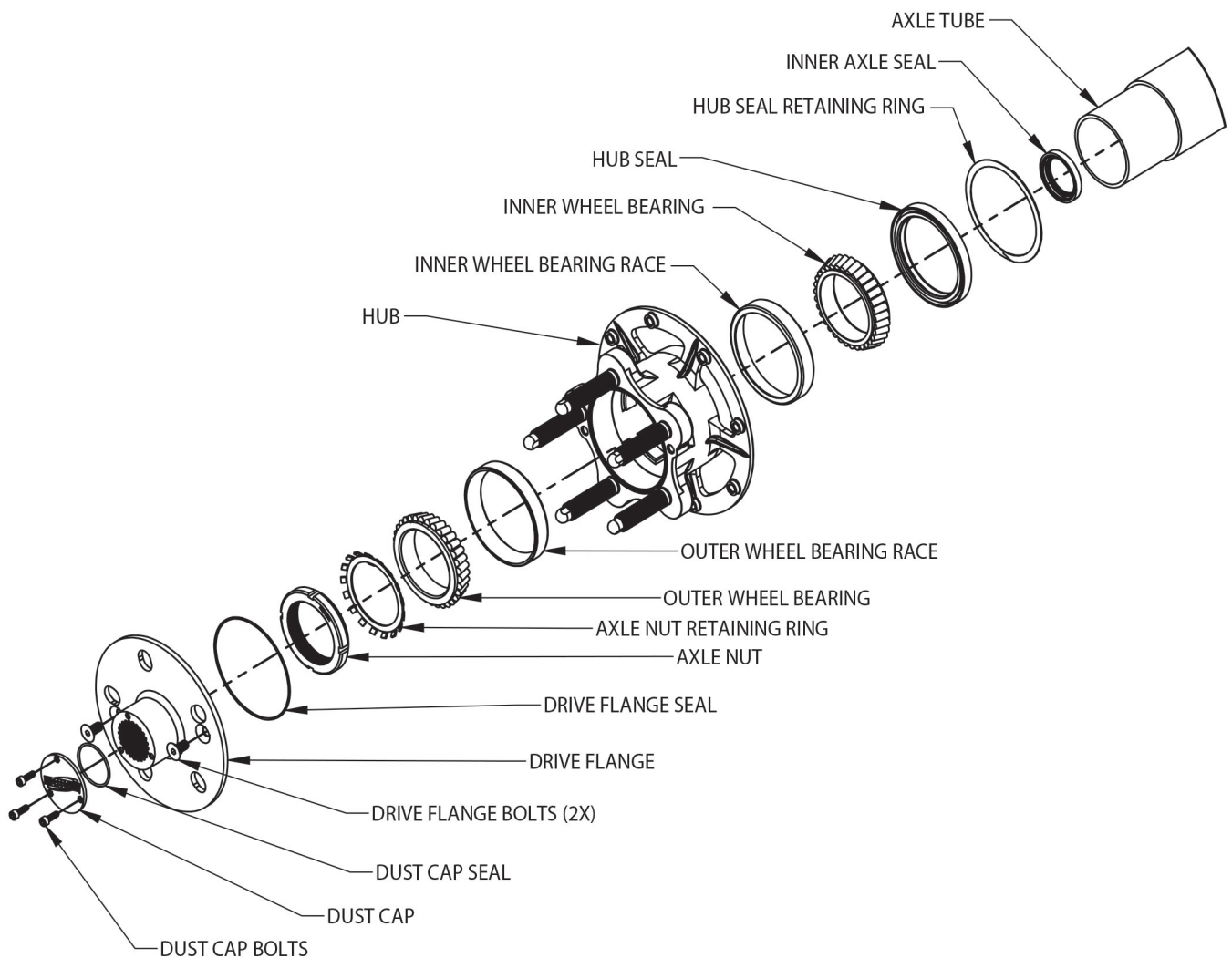

INSTRUCTIONS

© 2021, Speedway Motors, Inc.

SPEEDWAY
motors®

- 13.** Install the coil-over shocks. To install the shock, first use a 5/8"-18 x 4-1/2" bolt, spacers and lock nut to secure the lower end of the shock to the rear end housing as shown. The remaining 5/8"-18 x 3" bolts, spacers, washer and lock nuts are used to install the top of the shocks into the rear crossmember.

Note: This kit is design to use 4" stroke shocks with a compressed length of 10-11" and an extended length of 14-15". Shock ends should be 5/8" bearings with a mounting width of 9/16". For recommended part numbers, please visit our website or contact one of our tech experts.

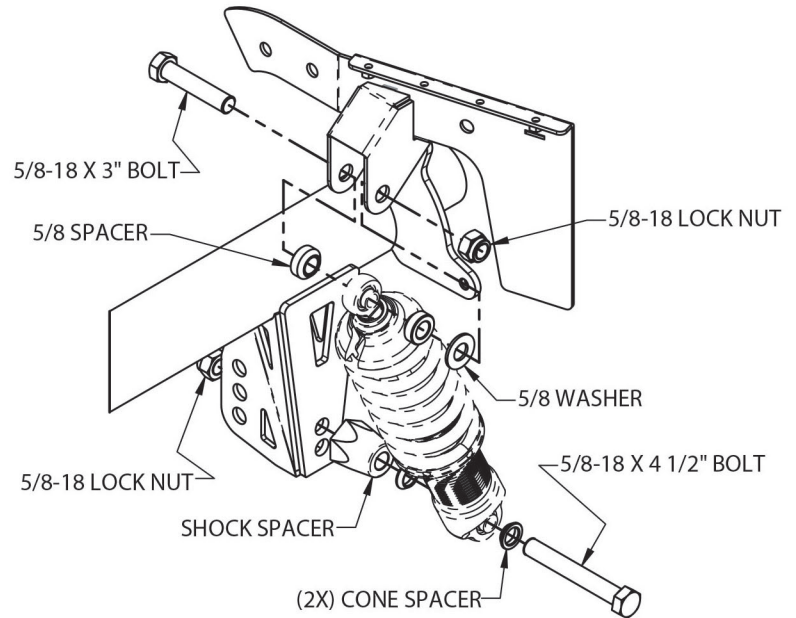

- 14.** Re-install: Drive shaft, fuel lines, brake lines, exhaust, etc.... Bleed the brakes. Fill the rear end with fluid. Install wheels and tires. Grease trailing arm johnny joints and torque arm pivot.

15. Alignment:

- Lower the car onto the ground and check for desired ride height. Adjust ride height if necessary by raising the car and spinning the adjusting collar on the coil-over.
- Once the ride height has been set, lower the car onto the ground and make sure the rear end is centered in the car body.
- Now that the ride height is set, check your rear end alignment. Adjust if necessary.

Note: This is difficult to do accurately and a professional alignment is recommended. This method will get you close enough to drive the car to an alignment shop.