



350 S. St. Charles St. Jasper, In. 47546
Ph. 812.482.2932 Fax 812.634.6632

www.ridetech.com

Part # 11320210
78-88 GM "G" Body Complete HQ Series CoilOver System

Front Components:

| | | |
|---|----------|-----------------------------------|
| 1 | 11323510 | Front HQ Series CoilOvers |
| 1 | 11329599 | Front Tru-Turn Suspension Package |
| 1 | 11329100 | Front MuscleBar |

Rear Components:

| | | |
|---|----------|--------------------------|
| 1 | 11326699 | Rear Upper Strong Arms |
| 1 | 11324499 | Rear Lower Strong Arms |
| 1 | 11326110 | Rear HQ Series CoilOvers |
| 1 | 11329102 | Rear MuscleBar |
| 1 | 85000000 | Spanner Wrench |



350 S. St. Charles St. Jasper, In. 47546

Ph. 812.482.2932 Fax 812.634.6632

www.ridetech.com

Part # 11323510
78-88 GM "G" Body HQ Series Front CoilOvers
For Use w/ StrongArms

Shock Assembly:

| | | |
|---|----------|---------------------------------|
| 2 | 24139999 | 3.6" stroke HQ Series shock |
| 2 | 90009988 | 2" adjustable threaded stud top |
| 2 | 90001994 | .625" I.D. bearing |
| 4 | 90001995 | Bearing snap ring |

Components:

| | | |
|---|----------|------------------------------------|
| 2 | 59080700 | Coil spring – 8" long / 700 # rate |
| 2 | 90002312 | 2" stud top base |
| 2 | 90002222 | Spring retainer kit |
| 2 | 90002070 | ¾" Dropped upper mount |
| 2 | 90001902 | Aluminum cap for Delrin ball |
| 2 | 90001903 | Delrin ball upper half |
| 2 | 90001904 | Delrin ball lower half |
| 4 | 70010828 | Delrin Spring Washer |

Hardware:

| | | | |
|---|----------|-------------------------|-------------------|
| 2 | 99562003 | 9/16" SAE Nylok jam nut | Stud top hardware |
|---|----------|-------------------------|-------------------|

COILOver

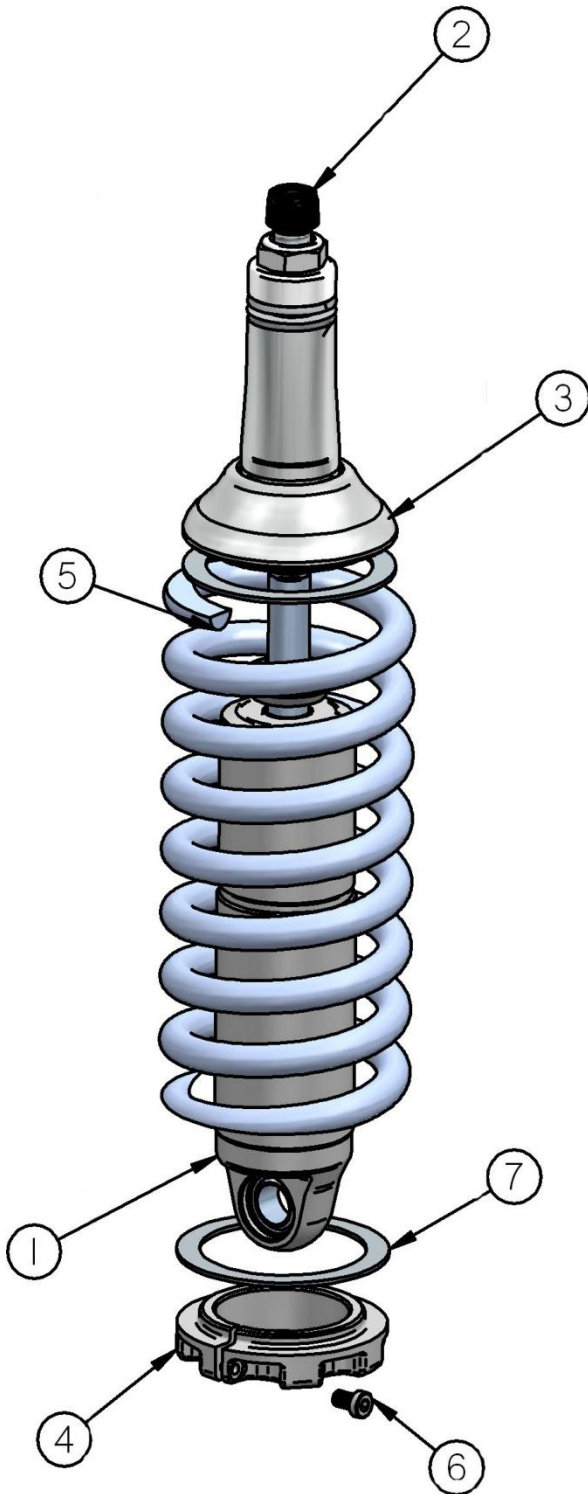

1. Impact Forged, Monotube shock
2. Rebound adjustment knob (SA Only)
3. Upper coil spring retainer $\frac{3}{4}$ " drop
4. Lower coil spring retainer
5. High tensile coil spring
6. Set screw
7. Delrin Spring Washer

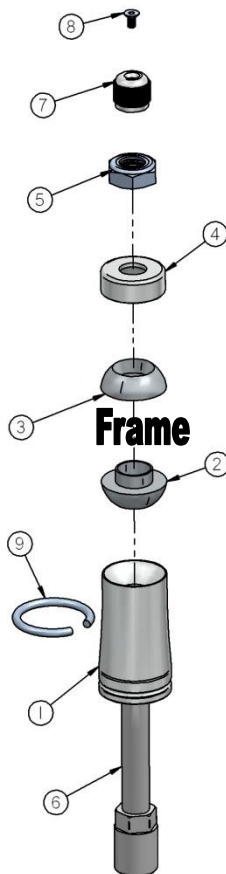

1. Stud top base
2. Lower Delrin ball half
3. Upper Delrin ball half
4. Aluminum cap
5. $\frac{9}{16}$ " Nylok jam nut
6. Threaded stud
7. Adjustment knob (SA Only)
8. Screw
9. Snap ring

COILOver

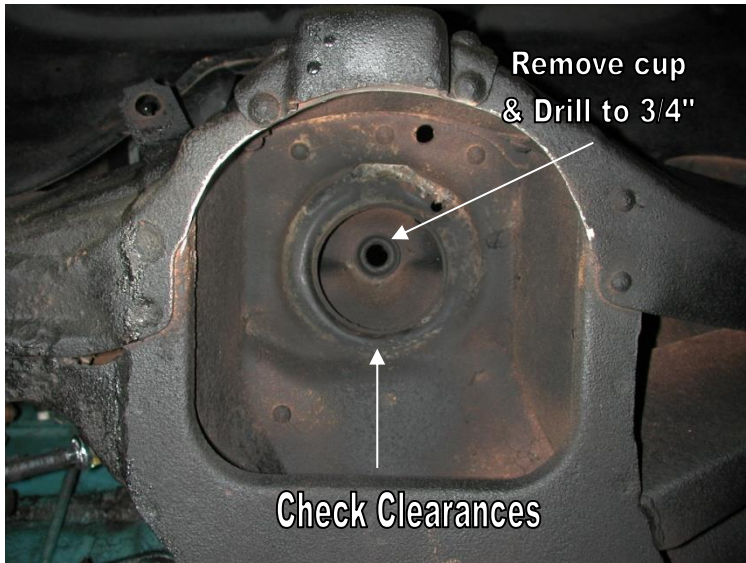

1. To allow the step in the lower Delrin ball half to slide into the factory shock hole, the bushing cup (if your car has one) will need to be removed and the hole may need to be drilled out to $\frac{3}{4}$ ".

2. Assemble the CoilOver then place into the coil spring pocket w/ the stud and lower Delrin ball sticking through the factory shock hole.

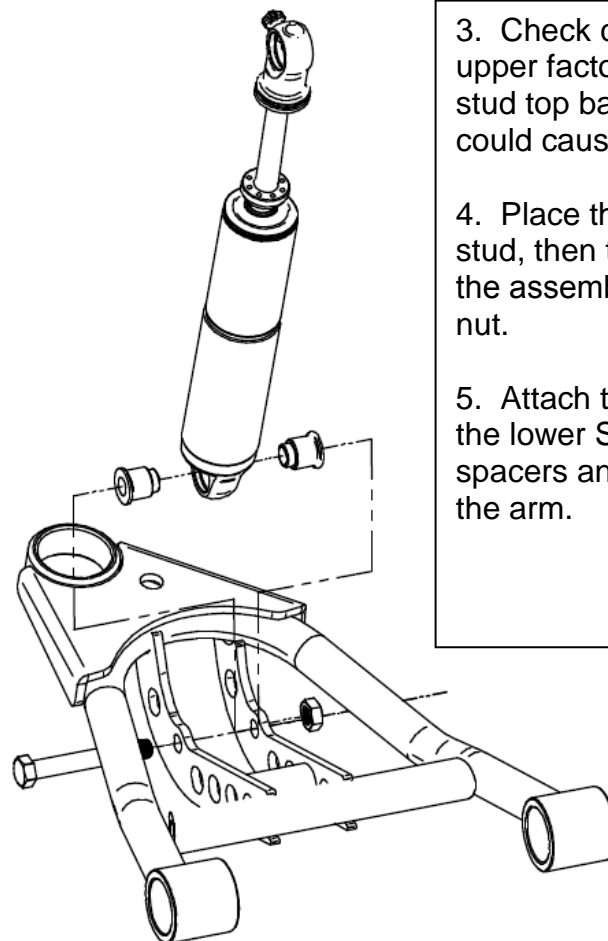

3. Check clearance between the upper factory spring retaining lip and stud top base. Allowing this to hit could cause the shock to break, this

4. Place the upper Delrin ball over stud, then the aluminum cap. Secure the assembly w/ the 9/16" Nylok jam nut.

5. Attach the bottom of the shock to the lower StrongArms using the spacers and hardware supplied w/ the arm.

ridetech



350 S. St. Charles St. Jasper, In. 47546

Ph. 812.482.2932 Fax 812.634.6632

www.ridetech.com



Part # 11329599 78-88 GM "G" Body Tru-Turn Suspension Package

Front Components:

- | | | |
|---|----------|-------------------|
| 1 | 11323699 | Upper Strong Arms |
| 1 | 11322899 | Lower Strong Arms |
| 1 | 11329500 | Tru Turn System |

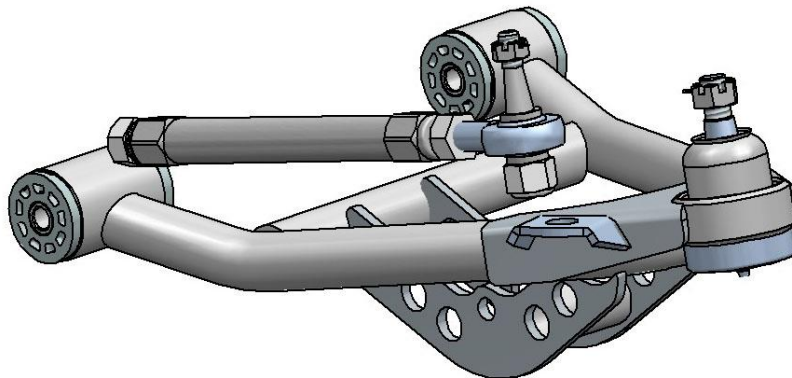
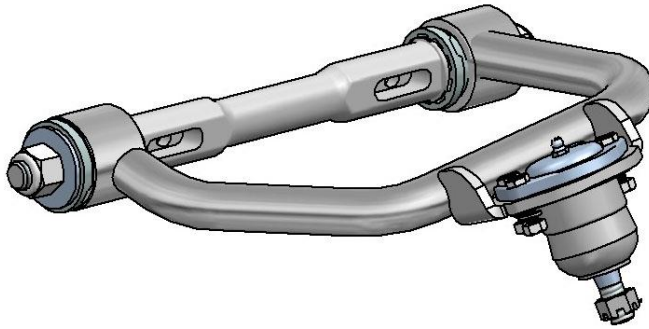



350 S. St. Charles St. Jasper, In. 47546

Ph. 812.482.2932 Fax 812.634.6632

www.ridetech.com

Part # 11323699
78-88 GM "G" Body Upper StrongArms

Components:

| | | |
|---|----------|--|
| 1 | 90002379 | Drivers side arm |
| 1 | 90002380 | Passenger side arm |
| 2 | 90000913 | Upper ball joint |
| 2 | 90000914 | Caster Adjustable Cross shaft w/Hardware |
| 2 | 70010826 | Delrin Bushing – no ledge |
| 2 | 70010827 | Delrin Bushing – small ledge |
| 4 | 70010759 | Delrin Bushing – outer |
| 4 | 90002737 | Cross shaft T-washer |
| 4 | 70011955 | Zero Offset Caster Slugs |

Hardware:

| | | | |
|---|----------|---------------------------|----------------------|
| 4 | 99431009 | 7/16-14 x 2 1/2" Hex Bolt | Cross shaft to Frame |
| 4 | 99432001 | 7/16"-14 Nylok Nut | Cross shaft to Frame |
| 4 | 99433002 | 7/16" SAE Flatwasher | Cross shaft to Frame |

STRONG ARMS™

by Air Ride Technologies



1. Fasten the upper arm to the frame using the supplied hardware. Reinstall the current alignment shims, but **vehicle must be realigned.**

2. Drop ball joint down through upper arm. Slide ball joint boot over stud, then place boot retainer over the boot. Clamp assembly tight w/ the hardware supplied.

3. Fasten the ball joint to the spindle w/ the new castle nut and cotter pin supplied.

4. Tighten the cross shaft nuts enough to create drag on the delrin bushings, the arm should still move.

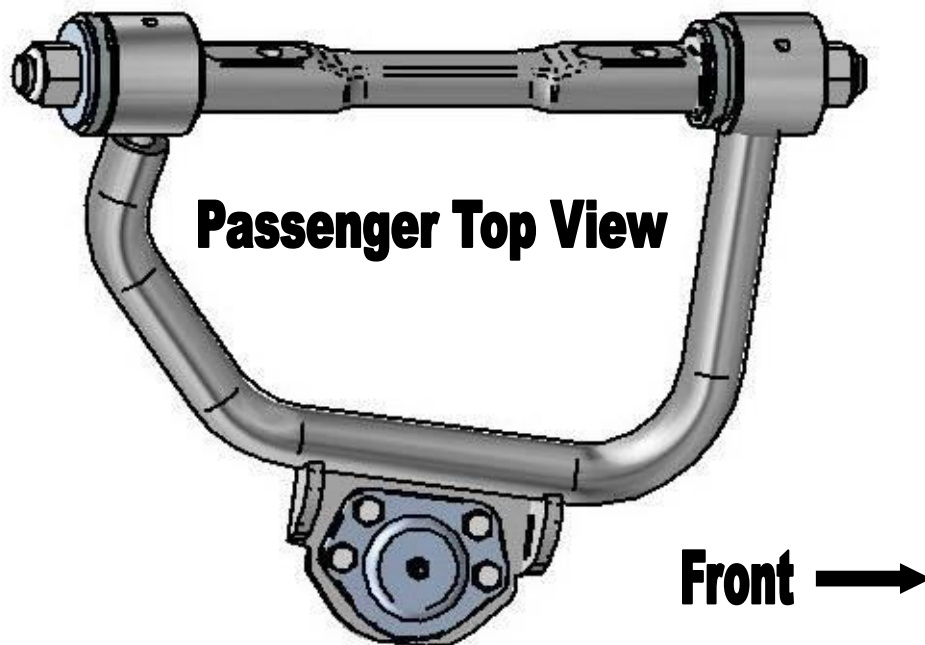

Passenger Side – Top View

| Item # | Description | Qty. |
|--------|-------------------------------|------|
| 1. | 5/8 – 18 Toplock Jam Nut | 4 |
| 2. | T-Washer | 4 |
| 3. | Outer Delrin bushing | 4 |
| 4. | Passenger side arm | 1 |
| 4. | Driver side arm | 1 |
| 5. | Inner Delrin bushing w/ledge | 2 |
| 6. | Caster Adjustable Cross shaft | 2 |
| 7. | Caster Slug | 2 |
| 8. | Inner Delrin bushing no ledge | 2 |

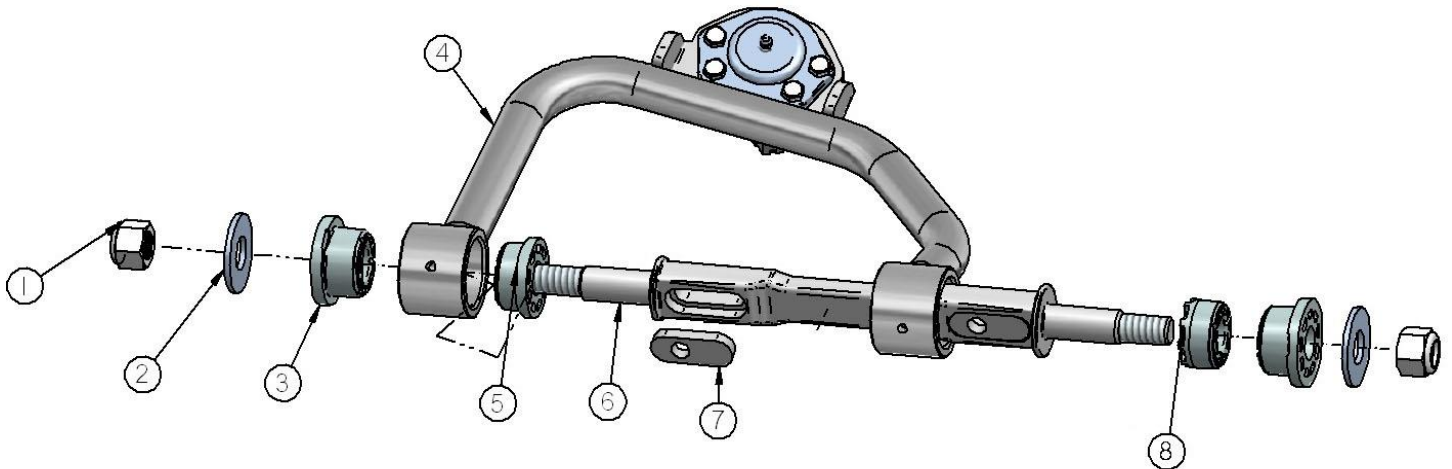

STRONG ARMS™

by Air Ride Technologies

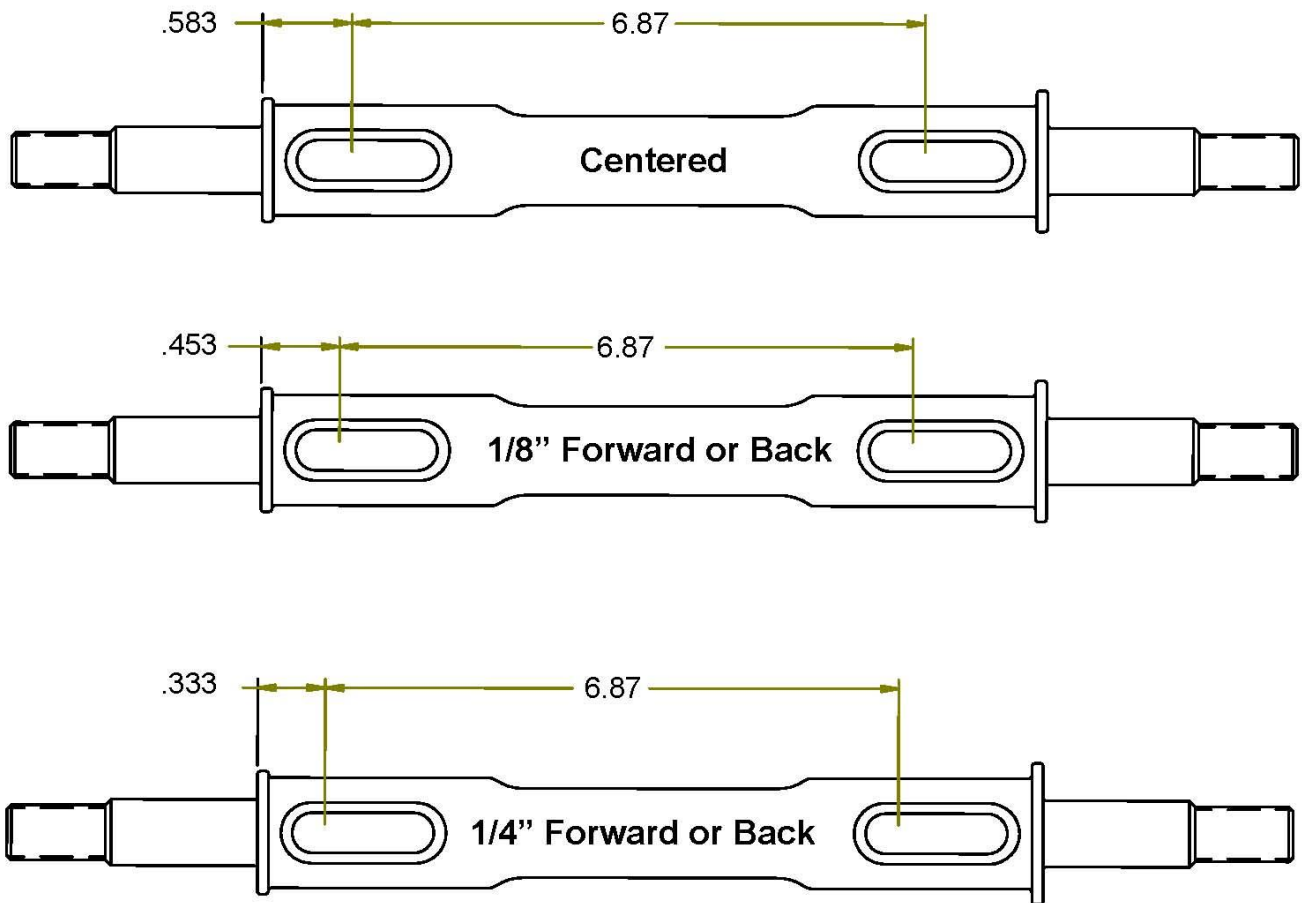

These Strong Arms come equipped with a changeable caster slug setup. This allows you to add or remove caster from the front suspension, if desired. The caster slugs that come in the kit are setup to put the control arm in the centered position, which is approximately 5 degrees of caster. The caster slugs allow you to add or remove caster without having to use a stack of shims. If more or less caster is desired, optional caster slugs can be purchased from your Ridetech dealer or Ridetech.

Caster Explained:

To understand caster you need to picture an imaginary line that runs through the upper ball joint and extends through the lower ball joint. From the side view the imaginary line will tilt forward or backward. The tilting of this imaginary line is defined as caster.

Caster is measured in degrees by using a caster camber gauge. If the imaginary line described above tilts towards the back of the car, at the top, then you will have positive caster. If the imaginary line tilts forward then you would have negative caster.

Positive caster provides the directional stability in your car. Too much positive caster will make the steering effort difficult. Power steering will allow you to run more positive caster. Negative caster requires less steering effort but can cause the car to wander down the highway.

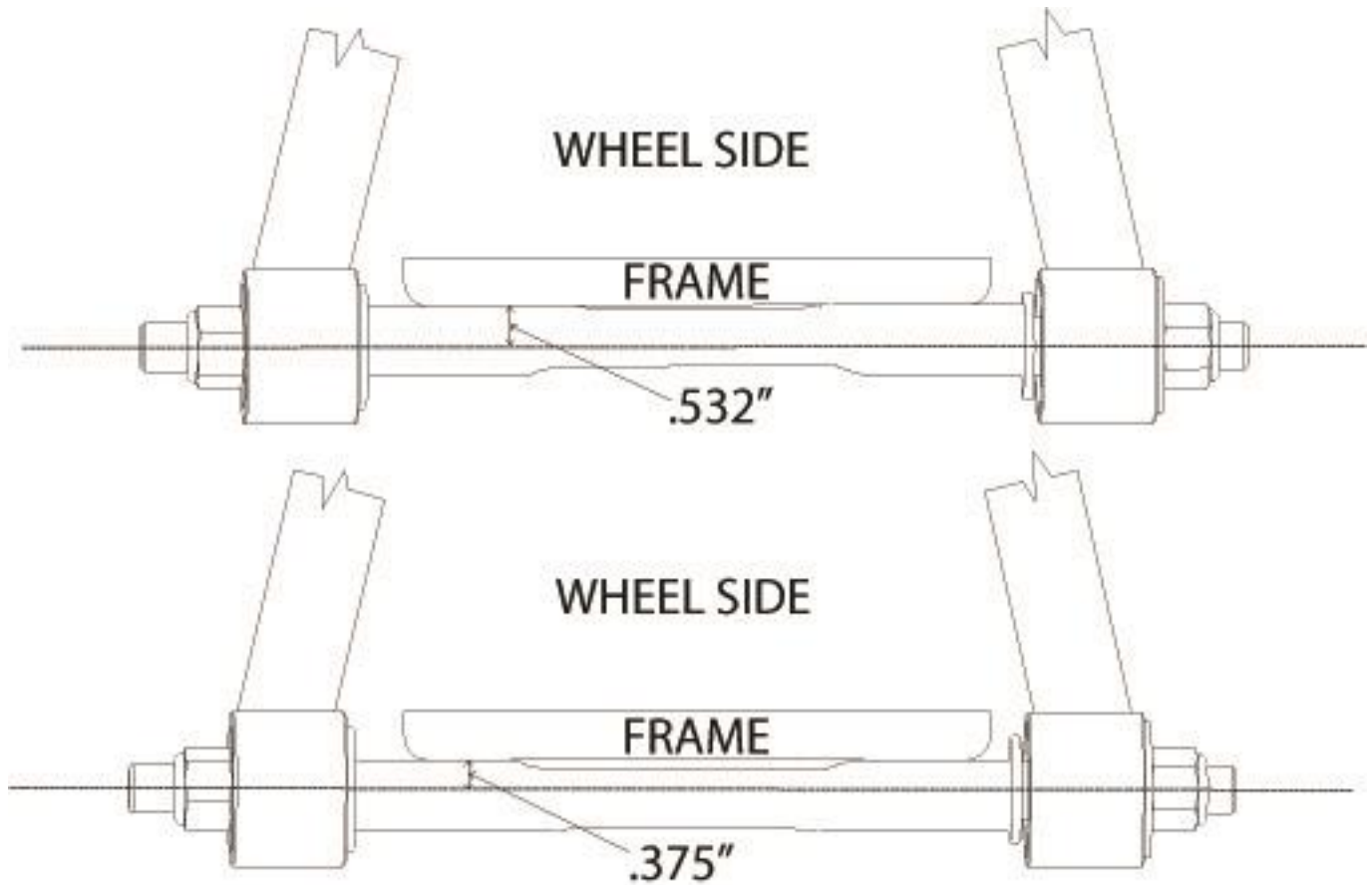

Offset Upper Cross Shaft

The cross shaft that is used in the upper control arm is offset. The offset combined with the caster slug option allows you to achieve the alignment setting you desire with minimal shims. To change the direction that the Icon faces, simply spin the cross shaft in the control arm.

If you are after an aggressive **Track or Autocross Alignment**, bolt the control arm to the frame bracket with the arm offset to the inside of the car (like the top illustration). The Ridetech Icon will be facing the engine.

If a **Street Alignment** is desired, bolt the control to the frame bracket with the arm offset to the outside of the car (like the bottom illustration). The Ridetech Icon will be facing the wheel.



350 S. St. Charles St. Jasper, In. 47546

Ph. 812.482.2932 Fax 812.634.6632

www.ridetech.com

Part # 11322899

78-88 GM "G" Body Lower StrongArms

For Use w/ Shockwaves or CoilOvers

Components:

| | | |
|---|----------|--------------------------------------|
| 1 | 90002377 | Driver side lower arm |
| 1 | 90002378 | Passenger side lower arm |
| 2 | 90000896 | Ball joint |
| 2 | 90000572 | Inner bushing sleeve |
| 2 | 90000573 | Inner bushing sleeve |
| 8 | 70010759 | Delrin bushing half |
| 4 | 90002062 | Aluminum spacer – Shock to lower arm |

Hardware:

| | | | |
|---|----------|------------------------|------------------------|
| 2 | 99501024 | ½"-13 x 3 ¼" Gr.5 bolt | Shockwave to lower arm |
| 2 | 99502001 | ½"-13 Nylok nut | Shockwave to lower arm |

STRONG ARMS™

by Air Ride Technologies

Installation Instructions



1. After removing the factory lower control arm, clean the bushing mounting surfaces on the frame to make sure they are fairly smooth.
2. Fasten the lower arm to the frame with the factory hardware.

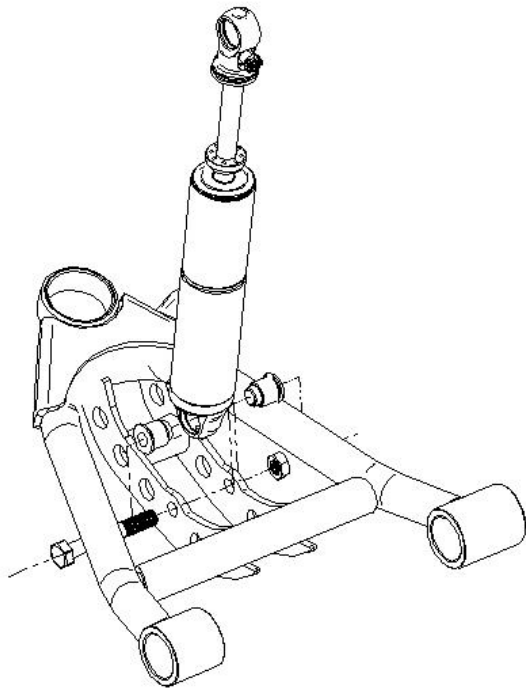

3. Swing the lower StrongArm up to the shock and secure with the $\frac{1}{2}$ " x $\frac{3}{4}$ " bolt and Nylok nut, an aluminum spacer must be installed on each side of the bearing.
4. Slide the ball joint boot over the stud, then push the stud up through the spindle. Secure w/ the new castle nut and cotter pin supplied.
5. Grease the ball joints.



350 S. St. Charles St. Jasper, In. 47546
Ph. 812.482.2932 Fax 812.634.6632
www.ridetech.com

Part # 11329500
78-88 G-Body TruTurn System without Spindles



| Item # | Part # | Description-Specification | Qty. |
|--------|----------|-------------------------------|------|
| 1. | 90001590 | Heim end | 2 |
| 2. | 99800002 | 5/8"-18 RH jam nut | 2 |
| 3. | 90002373 | Heim End Spacer | 4 |
| 4. | 99622003 | 5/8"-18 Lock Nut-35 ft lbs | 2 |
| 5. | 90002374 | Tie Rod Stud | 2 |
| 6. | 99432005 | 7/16"-20 castle nut-35 ft lbs | 2 |
| 7. | 90002375 | Adjusting sleeve | 2 |
| 8. | 99952002 | 3/32" cotter pin | 2 |
| 9. | 99800003 | 5/8"-18 LH jam nut | 2 |

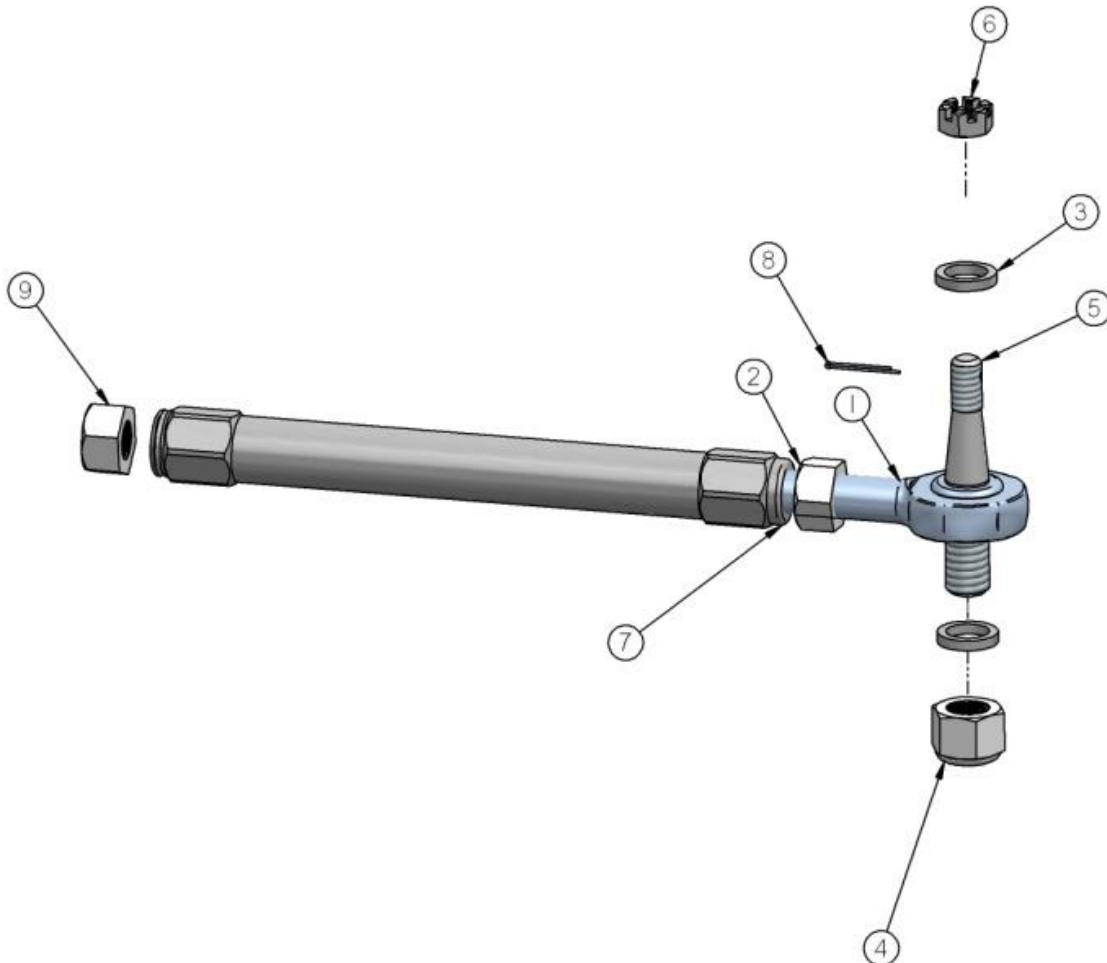



350 S. St. Charles Street Jasper, In. 47546 www.ridetech.com

Installation instructions:

NOTE: The number in (#) is the number of the part in the drawing on the previous page.

1. Raise and safely support the front of your vehicle at a comfortable working level
2. Remove existing outer tie rod and adjuster leaving the inner tie rod.
3. Install the (5) Tie Rod Stud into your factory spindle using the (6)7/16" castle nut. Torque the nut to 35 ft lbs and install (8) cotter pin. **NOTE:** If none of the holes line up tighten the nut until you can get the hole to line up with a slot.
4. Install the (7) Right Hand thread nut onto the (1) heim end and (9) Left hand nut onto the factory tie rod.
5. Antiseize the threads on the factory tie rod and heim end to prevent the threads from galling.
6. The left hand threaded side of the (7) adjuster goes onto the factory tie rod; it has a groove cut into the end of the adjuster. You will want the thread engagement the same on the tie rod end and the heim, the easy way to do this is set then nut on the tie rod 1 1/4" from the end of the tie rod and thread the adjuster on so that it touches the nut.
7. Install the heim end into the other end of the adjuster. Start by threading the lock nut all the way on the heim end and thread the heim end into the adjuster so that it touches the nut.
8. Install the heim end side of the tie rod onto the tie rod stud using the (3) aluminum spacer on top and bottom of the heim end and then install the (4)5/8" lock nut. Torque nut to 35 ft lbs.
9. Set the center to center length of the tie rod assembly to 17 3/4" by turning the adjuster out. This will get you close on the toe setting but it will need to be aligned.
10. Adjust the camber and toe roughly until you can get the vehicle to a proper alignment shop. The recommended alignment settings are:

Camber - -.5 to -1.5 [within .3 from side to side]

Caster – 4 to 7 degrees positive

Toe - 1/16" to 1/8" toe in

Feel free to experiment with alternative alignment settings that may be more appropriate for your particular driving style.

Installation notes:

- A. **MAKE SURE** that the cotter pins are properly installed in all appropriate places [C] to ensure that the castle nuts do not become loose and fail. These are VERY important connections!



350 S. St. Charles St. Jasper, In. 47546
Ph. 812.482.2932 Fax 812.634.6632

www.ridetech.com

11329100 78-88 GM "G" Body Front MuscleBar

Components:

| | | | |
|---|----------|--------------------------------------|-------------|
| 1 | 90001825 | Front sway bar (37.125") | |
| 1 | 90001821 | Driver side arm | |
| 1 | 90001822 | Passenger side arm | |
| 2 | 90001819 | Frame plate | |
| 2 | 90001820 | Frame bracket | |
| 2 | 90000926 | 10 mm 90 degree PosiLink | |
| 2 | 90000924 | 10 mm Straight PosiLink | |
| 2 | 90001823 | PosiLink Spacer (2.5") | |
| 4 | 90000717 | T-bushing (PosiLink to lower arm) | |
| 2 | 90001099 | Polyurethane frame bushing | |
| 2 | 99250001 | 1/4" - 28 straight grease zerk | |
| 1 | 90001092 | Tube of Lithium grease | |
| 2 | 99115009 | 10mm x 1.5 x 90mm stud (use Loctite) | In PosiLink |

Hardware Kit: 99010049

| | | | |
|---|----------|--------------------------------------|----------------------|
| 2 | 99111001 | 10 x 1.5 x 30mm Flat head Allen bolt | Frame plate to frame |
| 2 | 99111002 | 10 x 1.5 x 30mm bolt | Frame bracket |
| 4 | 99373003 | 3/8" SAE flat washer | Frame bracket |
| 4 | 99373005 | 3/8" lock washer | Frame bracket |
| 2 | 99373007 | 3/8" x 1" Self-tapping screws | Frame bracket |
| 6 | 99371017 | 3/8" x 1" Button head Allen bolt | Sway bar arm to bar |
| 6 | 99373003 | 3/8" SAE flat washer | Sway bar arm to bar |
| 6 | 99373005 | 3/8" lock washer | Sway bar arm to bar |
| 4 | 99112002 | 10mm Nylok nut | PosiLink |
| 4 | 99373003 | 3/8" flat washers | PosiLink |

MUSCLEbar™

POSI•Link™

11329100 Installation Instructions

1. This sway bar was designed for use with our lower StrongArms. Installation with other control arms may require modification.
2. Remove the end links from the factory sway bar. Then remove the bolts attaching the sway bar to the frame.



3. Bolt the frame plate to the frame using the factory sway bar holes. The front hole will use a 10mm x 30mm flat head Allen screw. The rear hole will use a standard 10mm x 30mm hex bolt.

4. Using the bracket as a guide, drill the front hole with a 5/16" bit. Then thread in 3/8" self-tapping screw.



5. Slide the poly bushing over the bar and lubricate with the lithium grease supplied.

6. Slide the bracket over the bushing and fasten the bar to the frame using the 10mm x 30mm hex bolt and 3/8" self-tapping screw.

Note: Future lubrication should only be done with non-petroleum based lubricants.



7. Bolt the sway bar arm to the bar using 3/8" x 1" Button head screws with flat washers and lock washers.



8. Fasten the 90 degree end of the PosiLink to the sway bar arm using a 10mm Nylok nut and flat washers

Note: There are two holes in the sway bar arm. For Shockwave/CoilOver arms use the front hole with the nut on the inside of the arm. For coils spring arms, use the rear hole with the nut on the outside of the arm(shown in picture).

9. Two T-bushing will be used on each side to attach the straight end of the PosiLink to the lower control arm. Secure with a 10mm Nylok nut.

10. Check PosiLink alignment through full suspension travel to ensure that it does not bind.



350 S. St. Charles St. Jasper, In. 47546
Ph. 812.482.2932 Fax 812.634.6632

www.ridetech.com

Part # 11326110
78-88 GM "G" Body Rear CoilOver Kit
HQ Series

Shock Assembly:

| | | |
|---|----------|--------------------------|
| 2 | 24159999 | 5" stoke HQ Series shock |
| 2 | 90002024 | 1.7" Eyelet |
| 4 | 90001994 | .625" bearing |
| 8 | 90001995 | Bearing snap ring |

Components:

| | | |
|---|----------|-------------------------------------|
| 2 | 59120150 | Coil spring – 12" long / 150 # rate |
| 2 | 90002222 | Spring retainer kit |
| 8 | 90002043 | Aluminum spacer - .5" I.D. |
| 4 | 70010828 | Delrin Spring Washer |
| 2 | 90002327 | Upper shock bracket |
| 1 | 90002325 | Driver side lower shock bracket |
| 1 | 90002326 | Passenger side lower shock bracket |
| 2 | 90002158 | Lower Shock Bracket |

Hardware:

| | | | |
|----|----------|-----------------------------|---------------------------------------|
| 4 | 99311001 | 5/16"-18 x 1" Gr. 5 bolt | Upper bracket to frame |
| 4 | 99312003 | 5/16"-18 Nylok nut | Upper bracket to frame |
| 8 | 99313002 | 5/16" SAE flat washer | Upper bracket to frame |
| 2 | 99501027 | 1/2"-13 x 3 3/4" Gr. 5 bolt | Shock bracket to trailing arm bracket |
| 6 | 99501002 | 1/2"-13 x 1 1/2" Gr.5 bolt | Shock bracket |
| 4 | 99501003 | 1/2"-13 x 2 1/2" Gr. 5 bolt | Shock to upper & lower brackets |
| 12 | 99502001 | 1/2"-13 Nylok nut | Lower shock bracket |
| 8 | 99503001 | 1/2" SAE flat washer | Lower shock bracket |

COILOver

Installation Instructions

1. Raise and safely support the vehicle by the frame rails.
2. Using a jack, slightly raise the axle approximately 1". Remove the shock absorbers.
3. Lower the axle down enough to remove the coil springs.
4. The exhaust tail pipes may need to be removed and/or modified for Shockwave installation.



5. Fasten the new upper shock bracket into the factory shock location using the 5/16" x 1" bolts, flat washers and Nylok nuts supplied.

Note: Position the bracket to offset the shock toward the center of the car.



6. Remove the lower trailing arm mounting bolt. (Do one side at a time to keep the axle from rotating).

7. Place the new lower shock bracket up against the factory lower shock bracket. Use a 1/2" x 1 1/2" bolt, Nylok nut and flat washers to fasten the new bracket to the factory bracket. Install the longer 1/2" x 3 3/4" bolt through the lower trailing arm mount, secure w/ the supplied flat washers and Nylok nuts.

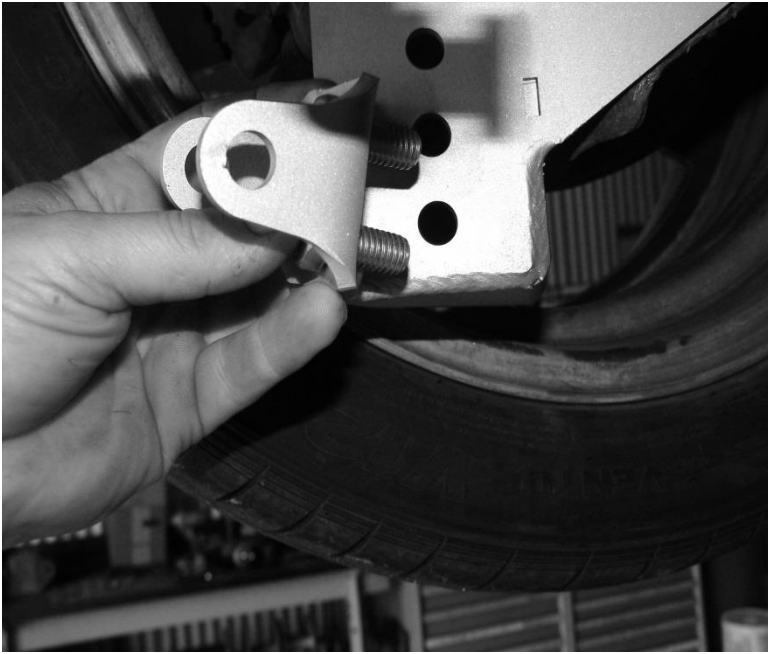

8. Install the Lower Bolt on Shock Bracket in the top 2 holes using (2) $\frac{1}{2}$ " x $1\frac{1}{2}$ " Hex Bolts, and (2) $\frac{1}{2}$ " Nylok Nuts.

The lower Bracket has 3 holes. The top 2 holes are the holes that the kit will normally use. If a lower ride height is desired, the bottom 2 holes can be used.



9. Install the aluminum spacers into the upper and lower eyes of the shock.



9. Fasten the shock to the upper bracket using a $\frac{1}{2}$ " x $2 \frac{1}{2}$ " bolt and Nylok nut.

10. Fasten the ShockWave to the lower bracket using a $\frac{1}{2}$ " x $2 \frac{1}{2}$ " bolt and Nylok nut.

12. Double check CoilOver clearances throughout full suspension travel.

13. Ride height on this shock is 14.5" from center eye to center eye.



350 S. St. Charles St. Jasper, In. 47546
Ph. 812.482.2932 Fax 812.634.6632

www.ridetech.com

Part # 11326699
78-88 GM "G" Body Rear Upper StrongArms

Components:

| | | |
|---|----------|----------------------------------|
| 2 | 90001118 | Upper StrongArm (Set to 11.125") |
| 2 | 90001589 | Kevlar lined Heim end |
| 4 | 90002065 | Aluminum spacers for Heim end |

Hardware:

| | | | |
|---|----------|--|------------|
| 2 | 99752004 | $\frac{3}{4}$ " SAE Jam nut | Heim end |
| 4 | 99501006 | $\frac{1}{2}$ " x 3 $\frac{1}{2}$ " USS Gr. 8 bolt | StrongArms |
| 4 | 99502001 | $\frac{1}{2}$ " USS Gr. 8 Nut | StrongArms |

Installation Instructions



1. The length of the upper bar should be set from the factory at 11.125" center to center. Ensure that the jam nut is tight.
2. Using the factory hardware, fasten the heim end to the frame bracket. An aluminum spacer must be installed on each side of the Heim end.



3. Fasten the other end of the bar to the axle using the factory hardware.
- Note:** Inspect the rubber bushing in the axle for wear or cracked. Replace with factory replacement bushing if needed.



350 S. St. Charles St. Jasper, In. 47546
Ph. 812.482.2932 Fax 812.634.6632

www.ridetech.com

Part # 11324499
78-88 GM "G" Body Rear Lower StrongArms

Components:

| | | |
|---|----------|---|
| 2 | 90001021 | Lower StrongArm – WW 19.25" |
| 8 | 90001089 | Poly bushing half – .75" I.D. x 1.5" O.D. x 1.125" long |
| 4 | 90000516 | Bushing sleeve - .5" I.D. x .75" O.D. x 2.375" long |
| 2 | 90001092 | Tube of Lithium grease – to lubrication bushing mounting surfaces |

Hardware:

| | | | |
|---|----------|------------------------------|-----------------------|
| 4 | 99431003 | 7/16" x 3" USS bolt | Swaybar to lower bars |
| 4 | 99432001 | 7/16" USS Nylok nut | Swaybar to lower bars |
| 8 | 99433002 | 7/16" SAE flat washer | Swaybar to lower bars |
| 4 | 99501006 | 1/2" x 3 1/2" USS Gr. 8 bolt | StrongArms to frame |
| 4 | 99502001 | 1/2" USS Gr. 8 Nylok nut | StrongArms to frame |

STRONG ARMS™

by Air Ride Technologies

Installation Instructions



1. Remove the sway bar (if equipped) and factory lower trailing arm. Do one side at a time to keep the axle from rotating.
2. Clean bushing mounting surfaces on frame. Lubricate w/ lithium grease supplied.
2. Attach to front on the lower StrongArm to the frame using factory hardware.
3. This arm has holes in the tube for sway bar attachment. Mount the bar so that the holes are closest to the axle.



4. Attach to rear of the lower StrongArm to the frame using the factory hardware.
- Note:** These polyurethane bushing are lubricated at the factory w/ lithium grease.
- Note:** Tighten the bolts enough to remove any lateral movement and apply moderate drag on bushings. Over-tightening can cause excessive suspension bind.

Ride Height

We have designed most cars to have a ride height of about 2" lower than factory. To achieve the best ride quality & handling, the shock absorber needs to be at 40-60% overall travel when the car is at ride height. This will ensure that the shock will not bottom out or top out over even the largest bumps. Measuring the shock can be difficult, especially on some front suspensions. Measuring overall wheel travel is just as effective and can be much easier. Most cars will have 4-6" of overall wheel travel. One easy way to determine where you are at in wheel travel is to take a measurement from the fender lip (center of the wheel) to the ground. Then lift the car by the frame until the wheel is just touching the ground, re-measure. This will indicate how far you are from full extension of the shock. A minimum of 1.5" of extension travel (at the wheel) is needed to ensure that the shock does not top out. If you are more than 3" from full extension of the shock then you are in danger of bottoming out the shock absorber.

Adjusting Spring Height

When assembling the CoilOver, screw the spring retainer tight up to the spring (0 preload). After entire weight of car is on the wheels, jounce the suspension and roll the car forward and backward to alleviate suspension bind.

- If the car is too high w/ 0 preload then a smaller rate spring is required. Although threading the spring retainer down would lower the car, this could allow the spring to fall out of its seat when lifting the car by the frame.
- If the car is too low w/ 0 preload, then preload can then be added by threading the spring retainer up to achieve ride height. On 2.6" - 4" stroke shocks, up to 1.5" of preload is acceptable. On 5-7" stroke shocks, up to 2.5" of preload is acceptable. If more preload is needed to achieve ride height a stiffer spring rate is required. Too much preload may lead to coil bind, causing ride quality to suffer.



350 S. St. Charles St. Jasper, In. 47546
Ph. 812.482.2932 Fax 812.634.6632

www.ridetech.com

Part Number - 11329102
78-88 GM "G" Body Rear MuscleBars

Components:

1 70001759 Rear sway bar

Hardware Kit (70001760) Includes:

4 7/16" x 3" bolts
4 7/16" Nylok nuts
8 7/16" flat washers

11329102 - Rear Bar Instructions

1. Look at the current sway bar installation.
2. Support the vehicle by the frame with lift jacks or jack stands, allowing the suspension to be unsupported.
3. Remove the four bolts holding the sway bar to the trailing arms.
4. Remove the factory sway bar from the vehicle.
5. Place the new sway-bar up to the trailing arms and push the bolts through the sway bars.
6. Tighten up the new bar.
7. Double check that all fasteners are tightened.

Your installation is finished. Enjoy your new sway bars!



ridetech

Assembly...



First using the supplied lower adjuster nut(90002222) thread the nut onto the shock from the bottom side as seen in figure 1



Next install delrin washers then coil spring over the top of the shock as seen in figure 2



Before the upper spring mount can be installed screw the adjuster knob on the upper eye mount to the firmest setting (clockwise) as seen in figure 3.



Slide the Derlin washer over the spring, Next slide the upper spring mount (90002222) over eyelet as seen in figure 4.



Install upper spring mount retainer clip (90002057) into the groove on the upper eyelet as seen in figure 5. Then reinstall adjuster to complete assembly.



The included set of bearing spacers (900002044) are used to adapt the coil-overs to just about any application. The supplied spacers allow the coil-overs to accept 5/8" or 1/2" bolts.

Shock adjustment 101- Single Adjustable

Rebound Adjustment:

How to adjust your new shocks.

The rebound adjustment knob is located on the top of the shock absorber protruding from the eyelet.

You must first begin at the ZERO setting, then set the shock to a soft setting of 20.



-Begin with the shocks adjusted to the ZERO rebound position (full stiff). Do this by rotating the rebound adjuster knob clockwise until it stops.



-Now turn the rebound adjuster knob counter clock wise 20 clicks. This sets the shock at 20. (settings 21-24 are typically too soft for street use).

Take the vehicle for a test drive.



-if you are satisfied with the ride quality, do not do anything, you are set!



-if the ride quality is too soft increase the damping effect by rotating the rebound knob clock wise 3 clicks.

Take the vehicle for another test drive.



-if the vehicle is too soft increase the damping effect by rotating the rebound knob clock wise 3 additional clicks.



-If the vehicle is too stiff rotate the rebound adjustment knob counter clock wise 2 clicks and you are set!

Take the vehicle for another test drive and repeat the above steps until the ride quality is satisfactory.

Note:

One end of the vehicle will likely reach the desired setting before the other end. If this happens stop adjusting the satisfied end and keep adjusting the unsatisfied end until the overall ride quality is satisfactory.