

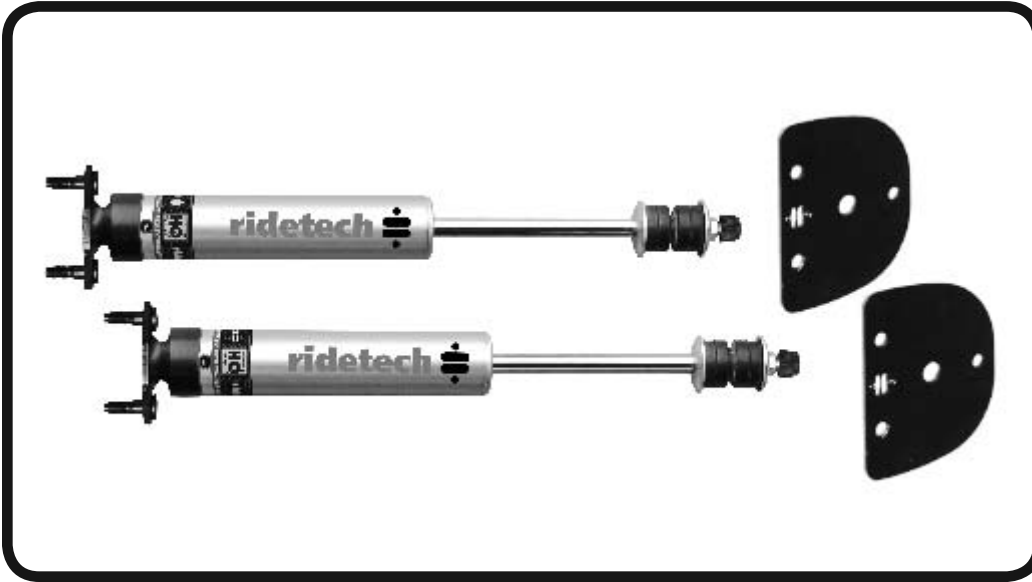

Part # 12109515 - 1967-1970 Mustang Front Shock Kit

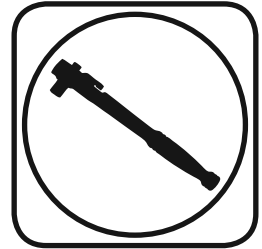

Recommended Tools



HQ Series Front Shock Kit Installation Instructions

Table of contents

- Page 2..... Components & Getting Started
- Page 3..... Shock Installation
- Page 4..... Stud Bushings & Shock Adjustment

THE RIDETECH DELRIN BUSHINGS (12109590), COILSPRINGS (12102350/12102351) & SWAY BAR (12109120) ARE RECOMMENDED TO ACHIEVE MAXIMUM PERFORMANCE.





3.85" HQ Series Smooth Body Shocks

Major ComponentsIn the box

Part #	Description	QTY
23139999	3.85" Stroke Shock	2
90002104	Stud Plate (Installed on Shock)	2
99371039	3/8"-24 x 5/8" FHCS (Installed on Shock)	2
99311020	5/16"-24 x 1 1/4" BHCS (Installed on Shock)	2
72000229	Stud Plate Bushings	2
70011140	Stud Top Bushings	4
70011141	Stud Top Bushing Washers	4
90002613	Upper Shock Mounting Plate	2

HARDWARE

Part #	Description	Usage	QTY
99372006	3/8"-24 Jam Nut	Upper Shock Bushings	4
99312001	5/16"-24 Nylok Nut	Lower Shock Mount	4
99313002	5/16" Flat Washer	Lower Shock Mount	4
99371027	3/8"-16 x 1" Carriage Bolt	Upper Shock Mount Plate	6
99373003	3/8" Flat Washer	Upper Shock Mount Plate	6
99372002	3/8"-16 Nylok Nut	Upper Shock Mount Plate	6

Getting Started.....

FOR OPTIMUM PERFORMANCE, THIS KIT SHOULD BE USED IN CONJUNCTION WITH THE STREET-GRIP COIL SPRINGS, DELRIN BUSHINGS, AND SWAY BAR.

1. Remove the OEM shock setup along with the OEM upper shock mount. If the car is equipped with a shock tower brace, it will need to be moved out of the way to install the new Upper Mount. It can be reinstalled while installing the new Upper Mount.

REPLACE THE CONTROL ARM BUSHINGS AND COIL SPRINGS BEFORE INSTALLING THE NEW SHOCK KIT.



Shock Installation

2.

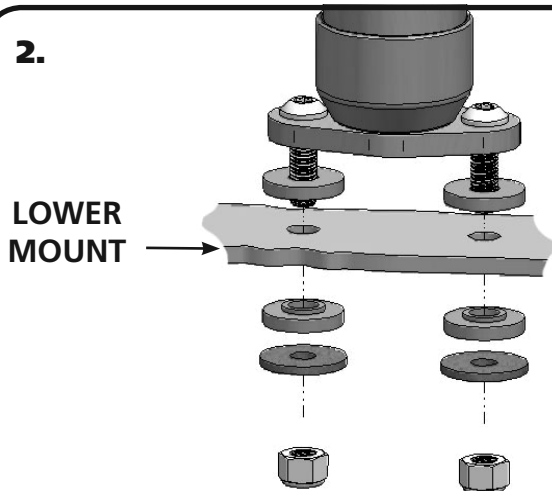

2. **(Figure 2)** shows the assembly of the lower shock bushings. Install a Bushing on the each of threads protruding through the lower shock plates.

3.



3. Using **(Figure 5)**, install a Stud Top Bushing Washer and Bushing on the Stud Top of the Shock. Insert the Shock through the OEM opening. Insert the studs into the openings in the lower mount. Using **(Figure 2)** as a reference, install a Bushing, Washer and Nut on each stud and tighten.

4.



4. Insert the supplied 3/8"-16 x 1" Carriage Bolts in the OEM keyhole slots in the top of the shock tower. Install the Upper Shock Plate on the Carriage Bolts with the Stud Top of the Shock inserted into the center hole. The Inner Hole on the Shock Plate is offset if the holes are not lining up, FLIP IT OVER. If the car has a strut tower brace, install in on top of the plate. Once everything is in place, install a 3/8" Flat Washer & 3/8"-16 Nylok Nut on the threads sticking up. Tighten the hardware.



Stud Bushings and Shock Adjustment

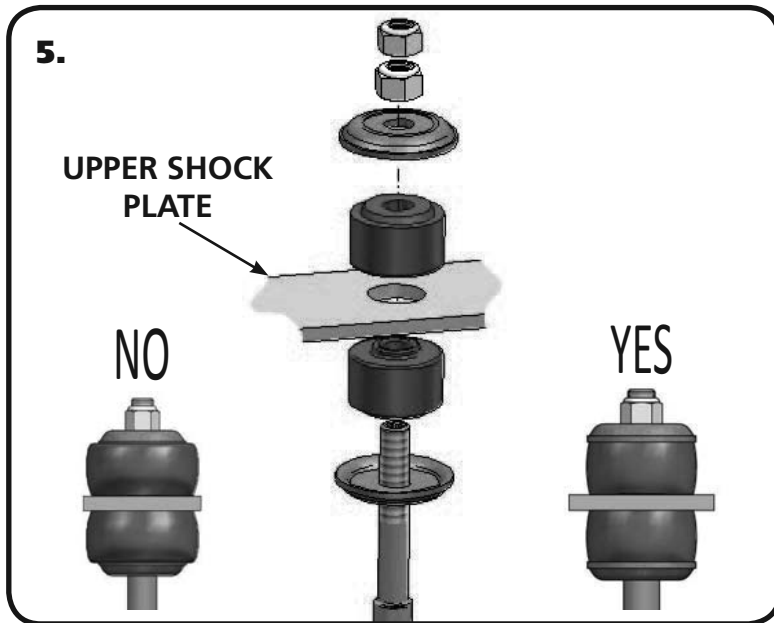

5. Install a Stud Top Bushing & Bushing Washer on the Shock. Install a 3/8"-24 Jam nut on the threads and tighten until the Bushings just start to bulge. Install a 2nd 3/8"-24 Jam Nut and tighten it against the 1st.

Shock adjustment 101- Single Adjustable

Rebound Adjustment:

How to adjust your new shocks

The rebound adjustment knob is located on the top of the shock absorber protruding from the eyelet or stud top. You must first begin at the ZERO setting, then set the shock to a street setting of 12 or handling setting of 8.

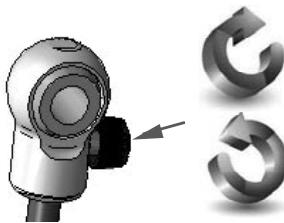

-Begin with the shocks adjusted to the ZERO rebound position (full stiff). Do this by rotating the rebound adjuster knob clockwise until it stops.

-Now turn the rebound adjuster knob counter clockwise 12 clicks. This sets the shock at 12 for a street setting. If you are after a handling setting only go 8 clicks.

Take the vehicle for a test drive.

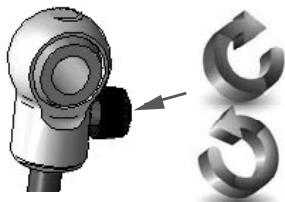

-if you are satisfied with the ride quality, do not do anything, you are set!

-if the vehicle is too soft increase the damping effect by rotating the rebound knob clockwise 3 additional clicks.

-If the vehicle is too stiff rotate the rebound adjustment knob counter clock wise 2 clicks and you are set!

Take the vehicle for another test drive and repeat the above steps until the ride quality is satisfactory.

Note:

One end of the vehicle will likely reach the desired setting before the other end. If this happens stop adjusting the satisfied end and keep adjusting the unsatisfied end until the overall ride quality is satisfactory.