

# INSTRUCTIONS

© 2020, Speedway Motors, Inc.

**SPEEDWAY**  
motors®

## 910-11598 and 910-11597 - Stromberg 97 Master and Standard Rebuild Kit

**Parts List - Stromberg Model EE-1 Carburetor**

#	Description	Included in 11598	Included in 11597
1	Gasket - Flange (Asbestos) 910-11050	x	x
2	Rod Assy - Accelerator Pump* (Long) 910-11599 (Short) 560-0001		
3	Fulcrum - Air Shuttie Lever		
4	Lever - Choke		
5	Spring - Choke Valve Tension		
6	Pin - Cotter, Accelerator Pump Lever		
7	Fulcrum - Accelerator Pump Lever		
8	Lever - Accelerator Pump		
9	Spring - Accelerator Pump Lever 910-11546		
10	Screw - Upper to Lower Body		
11	Lock Waser - Air Horn to Main Body		
12	Gasket - Upper Body	x	x
13	Pump Assy - Accelerator & Plunger	x	x
14	Gasket - Pump Felt	x	x
15	Washer - Pump Plunger	x	x
16	Spring - Pump Plunger, Upper	x	x
17	Retainer - Accelerator Pump & Plunger	x	x
18	Seat - Pump Return Spring	x	x
19	Spring - Accelerator Pump Return	x	x
20	Pin - Float Hinge		
21	Float Assembly 910-11549		
22	Needle & Seat Assembly	x	
23	Seat - Needle	x	x
24	Gasket - Needle Seat 910-11543	x	x
25	Valve - Needle	x	x
26	Jet Assy - Idling	x	
27	Jet Assy - Power	x	
28	Gasket - Power Jet	x	
29	Plug - Metering Jet		
30	Gasket - Drain Plug (3) 910-11542		x
31	Plug - Drain		
32	Valve Assy - Accelerator Pump Check	x	
33	Screw - Lower Body to Thottle Body 910-11560		
34	Lock Washer - Throttle Barrel	x	x
35	Gasket - Throttle Body	x	x
	Gauge - Float Level (Not Illustrated)		

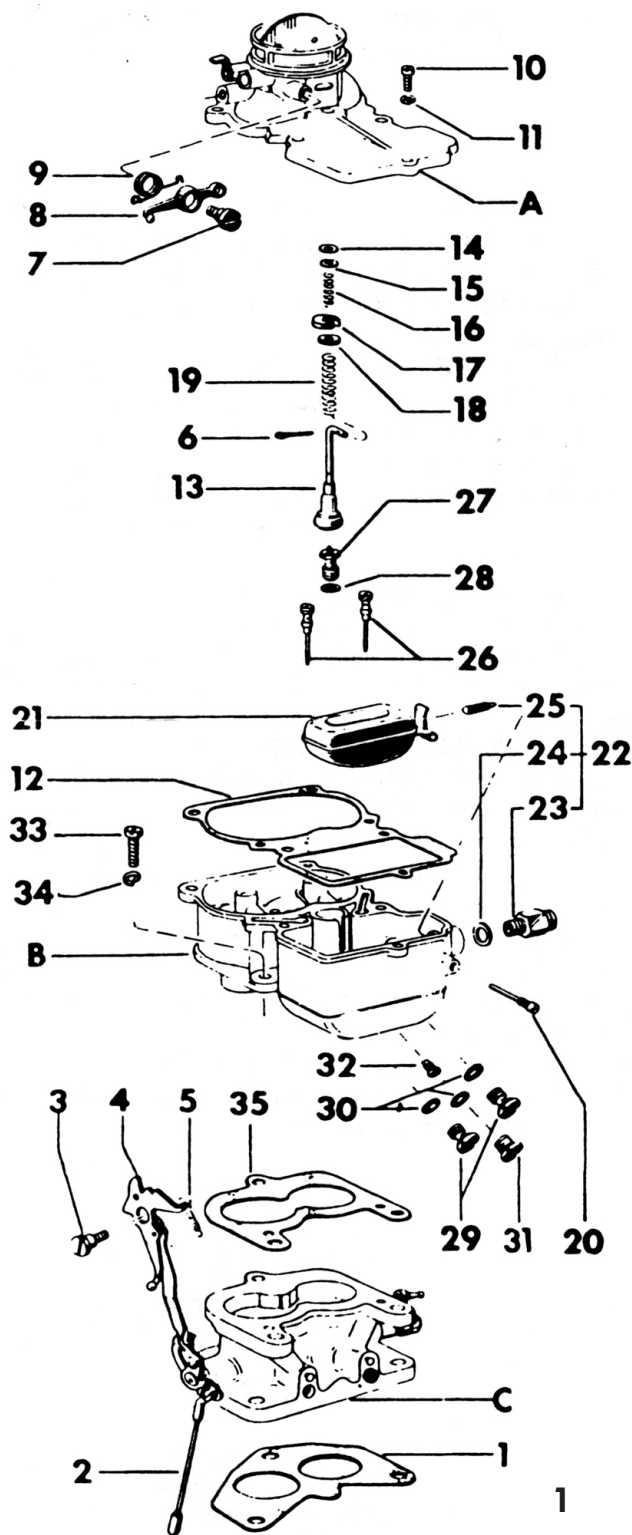

# INSTRUCTIONS

© 2020, Speedway Motors, Inc.

**SPEEDWAY**  
motors®

## PLEASE READ INSTRUCTIONS COMPLETELY BEFORE STARTING INSTALLATION.

Numbers used in disassembly and reassembly procedure are reference numbers on the illustration above. This economy kit is intended for use on carburetors that need cleaning and require minor replacement of parts, but otherwise are in satisfactory mechanical condition. The economy kit is not intended for the use on carburetors that are worn to the extent that replacement of the parts contained in the kit will not enable the carburetor to deliver proper performance and economy.

**1. Disassembly** - Remove carburetor from the engine and lift off flange gasket (1). Disconnect pump rod (2) at ball sockets. Remove air shuttle lever screw (3) and disengage choke lever (4) by disconnecting choke valve tension spring (5). Remove parts (6) through (9) in numerical order. Remove five cover screws (10) and their lock washers (11) and slide cover A off over pump plunger (13). Lift off body gasket (12). Remove parts (13) through (32) in numerical order. Remove the three throttle body screws (33) and their lock washers (34) and separate body B from flange C. Lift off throttle body gasket (35).

**2. Cleaning** - Cleaning must be accomplished with carburetor retor taken apart. Soak carburetor parts long enough to soften and remove all foreign material. Use a regular carburetor cleaning solvent, lacquer thinner or denatured alcohol. Use a small brush to aid in cleaning parts if necessary. Make certain carburetor bore is free of all hard carbon deposits. Do not boil carburetor in alkaline solution as it destroys protective coatings on casting. Blow out all passages with dry compressed air and check over carefully.

**3. Reassembly** - Install parts in body B in the order named: (30), (31), (29), (28), (27), (26), (25), (24) and (23). Insert new throttle body gasket (35) and attach body B to flange C with three throttle body screws (33) and their lock washers (34). Install float (21) with large pin (20). Gauge float to exact specification to produce correct gasoline level in bowl. (See illustration). Adjustments made by bending float tip, which contacts bottom of needle. Assemble pump parts in the order named: (13), (19), (18), (17), (16), (15) and (14). Insert in body, taking care not to wrinkle pump leather. Place new body gasket (12) over body B. Slide cover A over end of pump plunger (13) and fasten to body with five cover screws (10) and their lock washers (11). Install parts on cover A in the following order (9), (8), (7), (6), (5), (4) and (3). Attach pump link (2) at ball sockets. Place flange gasket (1) in place and attach carburetor.

**4. Idle Adjustment** - Adjust throttle stop screw (1) to crack throttle valves open slightly. Start engine and adjust idle adjusting needles (2) until engine idles smoothly. Regulate idle speed by readjusting throttle stop screw (1). Engine should idle at approximately 400 RPM. Readjustment of the throttle stop screw (1) may call for a slight readjustment of idle adjusting needles (2). If smooth idle can not be obtained by adjusting needles (2), there is something wrong with the carburetor or other parts of the engine which must be located and corrected.

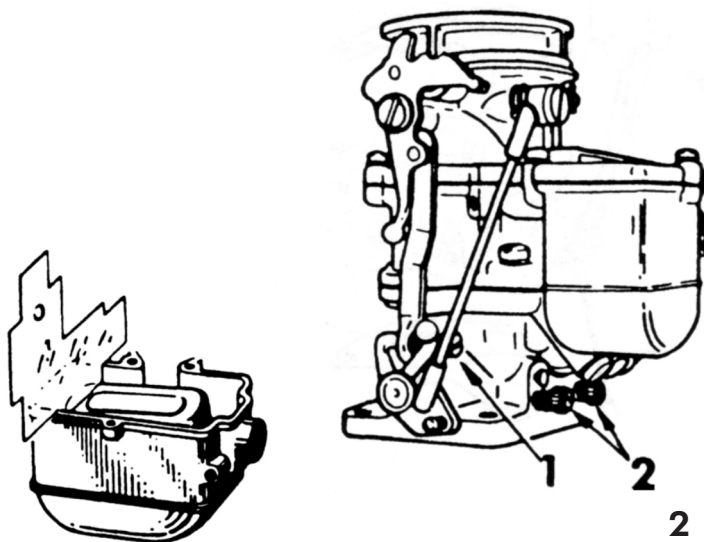

# IMPORTANT

**DISCLAIMER** In an effort to offer our customers low prices, quick service and great value, Speedway Motors reserves the right to change suppliers, specifications, colors, prices, materials without notice. Prices and policies that were current and in effect at the time of printing are also subject to change without notice. Quantities are limited on some items. Any unauthorized use of this catalog including words, photos or drawings is prohibited. Speedway is not responsible for any typographical errors, printing errors or misinterpretations

**WARRANTY DISCLAIMER** Purchasers understand and recognize that racing parts, specialized street rod equipment, and all other parts and services sold by Speedway Motors, Inc. are exposed to many and varied conditions due to the manner in which they are installed and used. Except for certain limited warranties, if any, set forth in Speedway Motors, Inc.'s current catalog with respect to the products and/or parts thereof identified on your invoice, each product, and each part thereof, is sold "as is", and "with all faults" and Speedway Motors, Inc. makes no warranties either expressed or implied, written or oral, with regard such products and services including, without limitation, any warranty of merchantability or fitness for a particular purpose. Without limiting the foregoing, there is no warranty expressed or implied as to whether the goods sold hereby will protect purchasers or ultimate end-users of such products and parts from injury or death. In no event shall Speedway Motors, Inc. be liable for any special, incidental or consequential damages, or any other damages whatsoever arising out of or connected with the use or misuse of the products and each part thereof. Purchasers acknowledge and agree that no person, entity or agent of Speedway Motors, Inc. has any authority to make any statement contrary to this disclaimer and that any warranty statements or representations allegedly made on behalf of Speedway Motors, Inc. by any such person, entity or agent are void. Purchasers are relying solely on their own skill and judgment to select, purchase and use suitable products and assume all responsibility and risk with regard thereto. Some local laws prohibit the use of utility jugs, funnels and barrel pumps for dispensing fuel. Please check your own state for more information, regulations or further direction in your use of the utility jugs, funnels and barrel pump described in Speedway's catalogs or on Speedway Motors websites. Some parts in this catalog are not legal for sale or use in California. Items sold in this catalog are for racing vehicles which may never be used on a highway. The use of manufacturer's names and symbols are for reference purposes only.

**DAMAGE CLAIMS** Please inspect all packages upon delivery and in the presence of the delivery driver when possible. The driver must note any visible damage and provide procedures for handling damage claims. To allow for a claims process, please retain original box, packing material and damaged merchandise. Contact Speedway Motors for instructions regarding damage claim within 5 days of receipt. Speedway Motors assumes no liability after this period.

**SHORTAGES** Please check the contents of your delivery to ensure that all parts ordered are received. Refer to your invoice to cross check all items received and inspect all packing materials for contents of small items. Retain original shipping box and packing materials. Orders may be split into multiple boxes which can be delivered on different days. Contact Speedway Motors for instructions regarding shortage claim within 5 days of receipt. Speedway Motors assumes no liability after this 5 day period.

**REFUSALS** All refused packages will be billed the freight to and from the destination and refused COD orders will be billed a 15% restocking charge plus freight to and from destination.

**WARRANTY CLAIMS** If the item is used or installed and a warranty claim request is submitted, warranty work is done by the manufacturer and may take up to 30 days for processing. Speedway Motors will be required to follow the manufacturer's warranty instructions to allow for a credit refund or exchange when specified.

**RETURNS** We want you to be satisfied with your purchase. If you are not satisfied, you may return your new, unused item within 60 days for refund or exchange.

All exchanged or returned merchandise must be in original factory condition with no modifications or alterations. Returned merchandise must include original packaging materials, warranty cards, manuals, instructions, etc. If the returned item requires repackaging, your refund / exchange will be subject to a repackaging charge. Return/Exchange transactions less than \$99 are excluded from the free shipping offer.

**HOW TO RETURN AN ITEM** Please re-pack the item in a sturdy box, include a copy of your invoice and completed return form. Returns must be shipped prepaid. CODs are not accepted. Shipping costs for exchanged merchandise will be charged to your credit card.

Items that are returned after 60 days are subject to a 15% restocking charges. Fiberglass items returned will be subject to a 15% restocking charge. We are unable to accept returns on electrical parts, video tapes, DVD's, books, special order or closeout merchandise.

**BRAKE INSTALLATION ALERT** The selection and installation of brake components should only be done by personnel experienced in the proper installation and operation of braking systems. The installer must use his/her own discretion to determine the suitability of all brake components and brake kits for every particular application. Speedway Motors, Inc. makes no warranties either expressed or implied including any warranty of merchantability or fitness for a particular purpose, other than those contained in its current catalog or website with respect to the goods identified on the face of the invoice. There is no warranty expressed or implied as to whether the goods sold hereby will protect the purchaser or ultimate user of such goods from injury or death.

**EXHAUST INSTALLATION ALERT** Exhaust systems and other component surface finishes are not permanent. Coatings, paint and other factory supplied cosmetic treatments are only intended to protect from surface corrosion in an unused state. No returns are allowed after the parts have been installed. Header flanges must be clean and clear of paint and surface contaminants prior to mating to exhaust gaskets. Exhaust fasteners must be re-torqued after the initial heat cycle and regularly thereafter to ensure a proper gasket seal is maintained. Should you decide to install this exhaust product at your home, be warned that pleasure car or light duty truck/van "bumper" jacks are intended for emergency use only. The use of frame contact jack stands in conjunction with a floor jack as a main support is highly recommended to minimize accidental dropping of a vehicle while the installation proceeds. We recommend the use of a shop hoist if possible. Please use caution! Speedway Motors, Inc. makes no warranties either expressed or implied including any warranty of merchantability or fitness for a particular purpose, other than those contain in its current catalog or website with respect to the goods identified on the face of the invoice. There is no warranty expressed or implied as to whether the goods sold hereby will protect the purchaser or ultimate user of such goods from injury or death.

**CHECK LOCAL LAW** Some parts are not legal for sale or use in California on any pollution controlled motor vehicles. These items are legal in California for racing vehicles only which may never be used upon a highway. Check local law.

Find the above info on our website:

[SpeedwayMotors.com/Info/FAQ](http://SpeedwayMotors.com/Info/FAQ)

© 2020, Speedway Motors, Inc.

**Speedway Motors, Inc.**

P.O. Box 81906 • Lincoln, NE 68501

800.979.0122 • [SpeedwayMotors.com](http://SpeedwayMotors.com)

