

INSTRUCTION

915-1004

Plastigauge - Green

©Speedway Motors, Inc. 2016

- 1) Remove the bearing cap and clean any oil or dirt from the journal.

NOTE: Checking bearing clearances with the engine in a position to where the bearing caps are supporting the weight of the crankshaft and flywheel will give an erroneous reading. This can be minimized by supporting the weight of the crankshaft with a jack under the counterweight adjoining the bearing being checked.

- 2) Place a piece of Plastigauge the FULL length of the bearing insert, about ¼" off center (see figure 1).

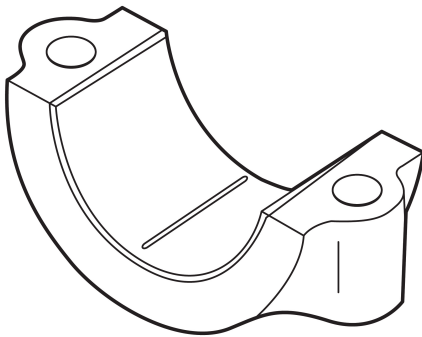

Figure 1

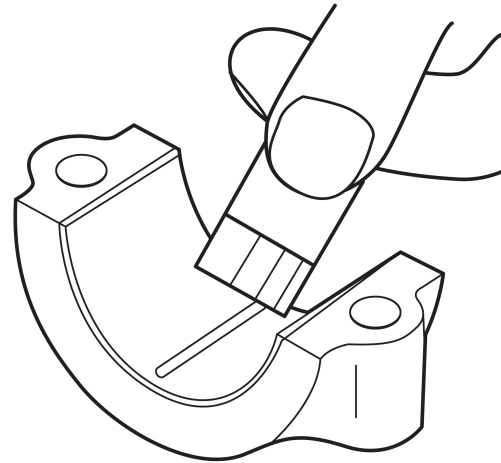

Figure 2

- 3) Rotate the crank 30 degrees from bottom dead center and re-install the cap. Tighten the bolts to spec with a torque wrench.
- 4) Remove the bearing cap. The compressed Plastigauge will adhere to either the bearing cap OR the crankshaft.
- 5) Compare the compressed Plastigauge at its WIDEST point with the graduations on the package (Figure 2). The number marked on the package indicates bearing clearance in thousandths of an inch or millimeters depending on which end of the package is compared. TAPER is indicated when one end of the compressed Plastigauge is wider than the other end. Measure BOTH ends of the compressed Plastigauge. The difference in the readings is the approximate amount of taper.
- 6) New bearing should be used if bearing clearance is not within specifications. Excessive taper indicates a new or re-worked crankshaft should be used.

IMPORTANT

DISCLAIMER

In an effort to offer our customers the low prices, quick service and great value, Speedway Motors reserves the right to change suppliers, specifications, colors, prices, materials. Each of the previous items is subject to change without notice. Speedway is not responsible for any typographical errors or misinterpretations. Quantities are limited on some items.

WARRANTY DISCLAIMER

The purchaser understands and recognizes that racing parts, specialized street rod equipment, and all parts and services sold by Speedway Motors, Inc. are exposed to many and varied conditions due to the manner in which they are installed and used. Speedway Motors, Inc. makes no warranties, either express or implied, including any warranty of merchantability or fitness for a particular purpose other than those contained in its current catalog with respect to the goods identified on the face of the invoice. There is no warranty expressed or implied as to whether the goods sold hereby will protect purchaser or ultimate user of such goods from injury or death. Speedway Motors assumes no liability after this period.

BRAKE INSTALLATION ALERT

The selection and installation of brake components should only be done by personnel experienced in the proper installation and operation of braking systems. The installer must use his/her own discretion to determine the suitability of all brake components and brake kits for every particular application. Speedway Motors, Inc. makes no warranties either expressed or implied including any warranty of merchantability or fitness for a particular purpose, other than those contained in its current catalog or website with respect to the goods identified on the face of the invoice, There is no warranty expressed or implied as to whether the goods sold hereby will protect the purchaser or ultimate user of such goods from injury or death.

DAMAGE CLAIMS

Always inspect your package upon delivery. Inspect all packages in the presence of the delivery driver. The driver must note any damage. Ask the driver the Carrier's procedures for handling damage claims. You must hold the original box, packing material and damaged merchandise for inspection or the carrier will not honor the claim. Notify Speedway Motors customer service department for instructions on returning damaged goods. Speedway is not responsible if no notification is given within 5 days of receipt.

SHORTAGES

Always check the contents of your delivery to insure all the parts that you ordered were received. Please read the invoice. Double check all packing materials, small items may be wrapped inside with these products. Shortages may occur from damage to the box, so save all packing materials. Inspect the box for holes that would allow parts to fall out. If you are missing any item(s) be sure to check your invoice for back orders or canceled items before calling the customer service department. If Speedway has to split a shipment into multiple boxes, packages may be delivered on different days. You need to contact the customer service department within 5 days of delivery to assure the prompt replacement. Speedway Motors assumes no liability after this period.

REFUSALS

All refused COD customers will be billed a 15% restocking charge plus freight to and from the destination! If you have questions please contact Speedway's customer service department.

WARRANTY CLAIMS

If an item has a manufacturer's warranty as being free from defects we will exchange only. If the item has been used and you are requesting warranty work, this may take up to 30 days as warranty work is done by the manufacturer NOT Speedway Motors. If you have any questions please contact customer service.

RETURNS

Speedway wants you to be satisfied with your purchase. If within 30 days after you receive your shipment you are not satisfied, you may return the item for refund or exchange. All exchanged or returned merchandise must be in original factory condition with no modifications or alterations. Returned merchandise must include all packaging materials, warranty cards, manuals, and accessories. If the items being returned need to be repackaged there will be a re-packing charge. Re-pack the item in a sturdy box and include a copy of your invoice and complete the form on the back of the invoice. You must ship orders back **PRE-PAID. WE DO NOT ACCEPT COD SHIPMENTS.** All exchanges need to have reshipping charges included. Items that are returned after 30 days are subject to 15% restocking charges. All fiberglass returned will have 15% restocking charge. No returns on electrical parts, video tapes, and books. Absolutely no returns on special order or close out merchandise.

FREE CATALOGS

Speedway Motors offers FREE catalogs for Race, Street, Sprint and Midget, Sport Compact and Pedal Car Restoration.

Some items are not legal for sale or use in California on pollution controlled motor vehicles. These items are legal in California for racing vehicles only which may never be used upon a highway.

**Speedway Motors Inc.,
P.O. Box 81906 Lincoln, NE 68501
800.979.0122 SpeedwayMotors.com**

